



GOVERNMENT OF TAMILNADU

STANDARD NINE

SCIENCE

A publication under Free Textbook Programme of Government of Tamil Nadu

Department of School Education

**Untouchability is Inhuman and a Crime**

## Government of Tamil Nadu

First Edition - 2018

Revised Edition - 2019, 2020

(Published under New Syllabus)

**NOT FOR SALE**

## Content Creation



State Council of Educational  
Research and Training  
© SCERT 2018

## Printing & Publishing



Tamil Nadu Textbook and  
Educational Services Corporation  
[www.textbooksonline.tn.nic.in](http://www.textbooksonline.tn.nic.in)

## PREFACE

This book is developed in a holistic approach which inculcates comprehending and analytical skills. It will be helpful for the students to understand higher secondary science in a better way and to prepare for competitive exams in future. This textbook is designed in a learner centric way to trigger the thought process of students through activities and to make them excel in learning science.

## HOW TO USE THE BOOK?

- This Science book for Standard IX has 25 units.
- Each unit has simple activities that can be demonstrated by the teacher. Few group activities are given for students to do under the guidance of the teacher.
- Infographics and Info-bits are added to enrich the learner's scientific perception.
- "Do you know?" and "More to know" placed in the units will be an eye opener.
- Glossary has been introduced to learn scientific terms.
- ICT corner and QR code are introduced in each unit for the digital native generation.

### How to get connected to QR Code?

- Download the QR code scanner from the google play store/apple app store into your smartphone.
- Open the QR code scanner application.
- Once the scanner button in the application is clicked, camera opens and then bring it closer to the QR code in the textbook.
- Once the camera detects the QR code, a URL appears in the screen. Click the URL and go to the content page.



# Table of Contents

Unit	Title	Page No	Month
1	Measurement	1	June
2	Motion	14	July
3	Fluids	26	August
4	Electric charge and Electric current	39	October
5	Magnetism and Electromagnetism	52	November
6	Light	66	December
7	Heat	80	January
8	Sound	91	February
9	Universe	102	March
10	Matter Around Us	113	June
11	Atomic Structure	125	July
12	Periodic Classification of Elements	138	August
13	Chemical Bonding	148	October
14	Acids, Bases and Salts	162	November
15	Carbon and its Compounds	172	January
16	Applied Chemistry	185	February
17	Animal Kingdom	199	June
18	Organisation of Tissues	210	July
19	Plant Physiology	226	August
20	Organ Systems in Animals	233	October
21	Nutrition and Health	247	November
22	World of Microbes	258	November
23	Economic Biology	273	January
24	Environmental Science	290	February
25	Computer - LibreOffice Impress	302	September
	Practicals	309	
	Glossary	318	



E - book



Assessment



DIGI links

 Learning Objectives

After completing this lesson, students will be able to

- understand the fundamental and derived quantities and their units.
- know the rules to be followed while expressing physical quantities in SI units.
- get familiar with the usage of scientific notations.
- know the characteristics of measuring instruments.
- use vernier caliper and screw gauge for small measurements.
- find the weight of an object using a spring balance.
- know the importance of accurate measurements.

**Introduction**

Measurement is the basis of all important scientific study. It plays an important role in our daily life also. While finding your height, buying milk for your family, timing the race completed by your friend and so on, you need to make measurements. Measurement answers questions like, how long, how heavy and how fast? Measurement is about assigning a number to a characteristic of an object or event which can be compared with other objects or events. It is defined as the determination of the size or magnitude of a quantity. In this lesson you will learn about units of measurements and the characteristics of measuring instruments.

**1.1 Physical Quantities and Units****1.1.1 Physical quantities**

Physical quantity is a quantity that can be measured. Physical quantities can be classified into two: fundamental quantities and derived

quantities. Quantities which cannot be expressed in terms of any other physical quantities are called fundamental quantities. Example: Length, mass, time, temperature etc. Quantities which can be expressed in terms of fundamental quantities are called derived quantities. Example: Area, volume, density etc.

Physical quantities have a numerical value and a unit of measurement (say, 3 kilogram). Suppose you are buying 3 kilograms of vegetable in a shop. Here, 3 is the numerical value and kilogram is the unit. Let us study about units now.

**1.1.2 Units**

A unit is a standard quantity with which the unknown quantities are compared. It is defined as a specific magnitude of a physical quantity that has been adopted by law or convention. For example, feet is the unit for measuring length. That means, 10 feet is equal to 10 times the definite pre-determined length, called feet.

Earlier, different unit systems were used by people from different countries. Some of the unit systems followed earlier are given below in Table 1.1.

**Table 1.1** Unit systems of earlier times

System	Length	Mass	Time
CGS	centimetre	gram	second
FPS	foot*	pound	second
MKS	metre	kilogram	second

\* foot is the singular of feet

At the end of the Second World War there was a necessity to use worldwide system of measurement. Hence, SI (International System of Units) system of units was developed and recommended by General Conference on Weights and Measures at Paris in 1960 for international usage.

## 1.2 SI System of Units

SI system of units is the modernised and improved form of the previous system of units. It is accepted in almost all the countries. It is based on a certain set of fundamental units from which derived units are obtained by proper combination. There are seven fundamental units in the SI system of units. They are also known as base units and they are given in Table 1.2.

The units used to measure the fundamental quantities are called fundamental units and the units which are used to measure the derived quantities are called derived units.

**Table 1.2** Fundamental quantities and their units

Fundamental quantities	Unit	Symbol
Length	metre	m
Mass	kilogram	kg
Time	second	s
Temperature	kelvin	K
Electric current	ampere	A
Luminous intensity	candela	cd
Amount of substance	mole	mol

With the help of these seven fundamental units, the units for other derived quantities are obtained and their units are given below in Table 1.3.

## 1.3 Fundamental Units

### 1.3.1 Length

Length is the extent of something between two points. The SI unit of length is metre. One metre is the distance travelled by light through vacuum in  $1/29,97,92,458$  second.

**Table 1.3** Derived quantities and their units

S.No	Physical quantity	Expression	Unit
1	Area	length $\times$ breadth	$m^2$
2	Volume	area $\times$ height	$m^3$
3	Density	mass / volume	$kgm^{-3}$
4	Velocity	displacement / time	$ms^{-1}$
5	Momentum	mass $\times$ velocity	$kgms^{-1}$
6	Acceleration	velocity / time	$ms^{-2}$
7	Force	mass $\times$ acceleration	$kgms^{-2}$ or N
8	Pressure	force / area	$Nm^{-2}$ or Pa
9	Energy (work)	force $\times$ distance	Nm or J
10	Surface tension	force / length	$Nm^{-1}$

In order to measure very large distance (distance of astronomical objects) we use the following units.

- Astronomical unit
- Light year
- Parsec

**Astronomical unit (AU):** It is the mean distance of the centre of the Sun from the centre of the Earth.  $1 \text{ AU} = 1.496 \times 10^{11} \text{ m}$  (Figure 1.1).

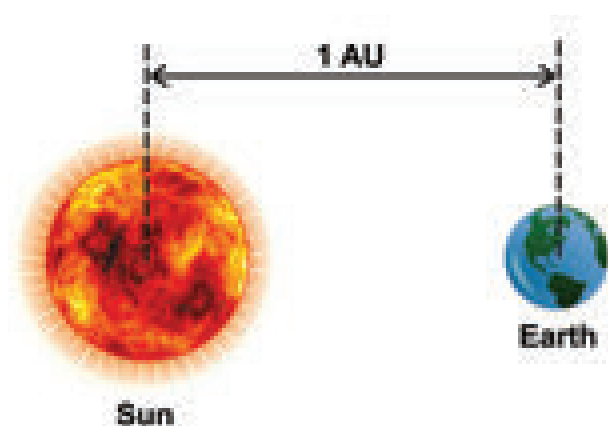

**Figure 1.1** Astronomical unit

**Light year:** It is the distance travelled by light in one year in vacuum and it is equal to  $9.46 \times 10^{15} \text{ m}$ .

**Parsec:** Parsec is the unit of distance used to measure astronomical objects outside the solar system.

1 Parsec = 3.26 light year.

**Table 1.4** Larger units

Larger units	In metre
Kilometre (km)	$10^3 \text{ m}$
Astronomical unit (AU)	$1.496 \times 10^{11} \text{ m}$
Light year (ly)	$9.46 \times 10^{15} \text{ m}$
Parsec (pc)	$3.08 \times 10^{16} \text{ m}$



The nearest star alpha centauri is about 1.34 parsec from the sun. Most of the stars visible to the unaided eye in the night sky are within 500 parsec distance from the sun.

To measure small distances such as distance between two atoms in a molecule, size of the nucleus and wavelength etc. we use submultiples of ten. These quantities are measured in Angstrom unit (Table 1.5).

**Table 1.5** Smaller units

Smaller units	In metre
Fermi (f) *	$10^{-15} \text{ m}$
Angstrom ( $\text{\AA}$ )*	$10^{-10} \text{ m}$
Nanometre (nm)	$10^{-9} \text{ m}$
Micron (micrometre $\mu \text{ m}$ )	$10^{-6} \text{ m}$
Millimetre (mm)	$10^{-3} \text{ m}$
Centimetre (cm)	$10^{-2} \text{ m}$

\* Unit outside SI system and still accepted for use.

### 1.3.2 Mass

Mass is the quantity of matter contained in a body. The SI unit of mass is kilogram (kg). One kilogram is the mass of a particular international prototype cylinder made of platinum-iridium alloy, kept at the International Bureau of Weights and Measures at Sevres, France.

The units gram (g) and milligram (mg) are the submultiples of ten (1/10) of the unit kg. Similarly quintal and metric tonne are multiples of ten ( $\times 10$ ) of the unit kg.

$$1 \text{ g} = 1/1000 \times 1 \text{ kg} = 0.001 \text{ kg}$$

$$1 \text{ mg} = 1/1000000 \times 1 \text{ kg} = 0.000001 \text{ kg}$$

$$1 \text{ quintal} = 100 \times 1 \text{ kg} = 100 \text{ kg}$$

$$1 \text{ metric tonne} = 1000 \times 1 \text{ kg} = 10 \text{ quintal}$$

## Atomic mass unit

Mass of a proton, neutron and electron can be determined using atomic mass unit (amu).

1 amu =  $(1/12)^{\text{th}}$  of the mass of  $\text{C}^{12}$  atom.

### More to Know

Mass of 1 ml of water = 1g

Mass of 1l of water = 1kg

Mass of the other liquids vary with their density.

### 1.3.3 Time

Time is a measure of duration of events and the intervals between them. The SI unit of time is second. One second is the time required for the light to propagate 29,97,92,458 metres through vacuum. It is also defined as  $1/86,400^{\text{th}}$  part of a mean solar day. Larger units for measuring time are day, month, year and millennium etc. 1 millennium =  $3.16 \times 10^9$  s.

### 1.3.4 Temperature

Temperature is the measure of hotness or coldness of a body. SI unit of temperature is kelvin (K). One kelvin is the fraction  $(1/273.16)$  of the thermodynamic temperature of the triple point of water (The temperature at which saturated water vapour, pure water and melting ice are in equilibrium). Zero kelvin (0 K) is commonly known as absolute zero. The other units for measuring temperature are degree celsius ( $^{\circ}\text{C}$ ) and fahrenheit (F).

## 1.4 Unit Prefixes

Unit prefixes are the symbols placed before the symbol of a unit to specify the order of magnitude of the quantity. They are useful to express very large and very small quantities. k (kilo) is the unit prefix in the unit, kilometer. A unit prefix stands for a specific positive or negative power of 10. Some unit prefixes are given in Table 1.6.

Table 1.6 Unit prefixes

Power of 10	Prefix	Symbol
$10^{15}$	peta	P
$10^{12}$	tera	T
$10^9$	giga	G
$10^6$	mega	M
$10^3$	kilo	k
$10^2$	hecto	h
$10^1$	deca	da
$10^{-1}$	deci	d
$10^{-2}$	centi	c
$10^{-3}$	milli	m
$10^{-6}$	micro	$\mu$
$10^{-9}$	nano	n
$10^{-12}$	pico	p
$10^{-15}$	femto	f

The physical quantities vary in different proportion like from  $10^{-15}$  m being the diameter of nucleus to  $10^{26}$  m being the distance between two stars and  $9.11 \times 10^{-31}$  kg being the mass of electron to  $2.2 \times 10^{41}$  kg being the mass of the milky way galaxy.

## 1.5 Rules and Conventions for writing SI Units and their Symbols

1. The units named after scientists are not written with a capital initial letter. E.g. newton, henry, ampere and watt.
2. The symbols of the units named after scientists should be written by the initial capital letter. E.g. N for newton, H for henry, A for ampere and W for watt.
3. Small letters are used as symbols for units not derived from a proper noun. E.g. m for metre, kg for kilogram.
4. No full stop or other punctuation marks should be used within or at



the end of symbols. E.g. 50 m and not as 50 m.

5. The symbols of the units are not expressed in plural form. E.g. 10 kg not as 10 kgs.
6. When temperature is expressed in kelvin, the degree sign is omitted. E.g. 283 K not as 283° K (If expressed in celsius scale, degree sign should be included e.g. 100°C not as 100 C, 108° F not as 108 F).
7. Use of solidus (/) is recommended for indicating a division of one unit symbol by another unit symbol. Not more than one solidus is used. E.g.  $\text{ms}^{-1}$  or  $\text{m/s}$ .  $\text{J/K/mol}$  should be  $\text{JK}^{-1}\text{mol}^{-1}$ .
8. The number and units should be separated by a space. E.g.  $15 \text{ kgms}^{-1}$  not as  $15 \text{ kgms}^{-1}$ .
9. Accepted symbols alone should be used. E.g. ampere should not be written as amp and second should not be written as sec.
10. The numerical values of physical quantities should be written in scientific form. E.g. the density of mercury should be written as  $1.36 \times 10^4 \text{ kgm}^{-3}$  not as  $13600 \text{ kgm}^{-3}$ .

## 1.6 Vernier Caliper and Screw Gauge

In our daily life, we use metre scale for measuring lengths. They are calibrated in cm and mm. The smallest length which can be measured by metre scale is called least count. Usually the least count of a scale is 1 mm. We can measure the length of objects upto 1 mm accuracy with this scale. By using vernier caliper we can have an accuracy of 0.1 mm and with screw gauge we can have an accuracy of 0.01 mm.

### 1.6.1 Description of Vernier caliper

The Vernier caliper consists of a thin long steel scale graduated in cm and mm called main

scale. To the left end of the main scale an upper and a lower jaw are fixed perpendicular to the bar. These are named as fixed jaws. To the right of the fixed jaws, a slider with an upper and a lower moveable jaw is fixed. The slider can be moved or fixed to any position using a screw. The Vernier scale is marked on the slider and it moves along with the movable jaws and the slider. The lower jaws are used to measure the external dimensions and the upper jaws are used to measure the internal dimensions of the objects. The thin bar attached to the right side of the Vernier scale is used to measure the depth of hollow objects.

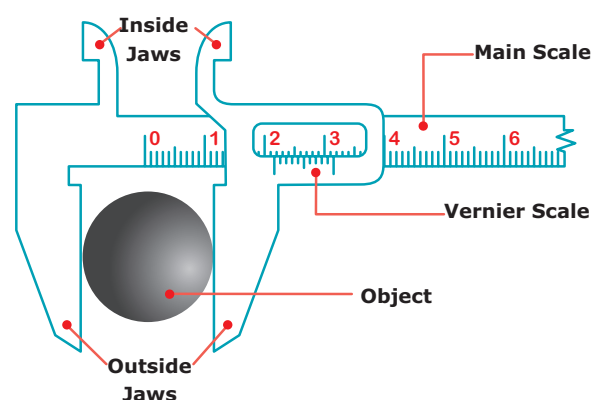

Figure 1.2 Vernier Caliper

### 1.6.2 Usage of Vernier caliper

The first step in using the Vernier caliper is to find out its least count, range and zero error.

#### a) Least count

Least count of the instrument (L.C)

$$= \frac{\text{Value of one main scale division}}{\text{Total number of vernier scale division}}$$

The main scale division will be in centimeter, further divided into millimetre. The value of the smallest main scale division is 1 mm. In the Vernier scale there will be 10 divisions.

$$\therefore \text{L.C} = \frac{1\text{mm}}{10} = 0.1\text{mm} = 0.01\text{cm}$$

#### b) Zero error

Unscrew the slider and move it to the left, such that both the jaws touch each other.

Check whether the zero marking of the main scale coincides with that of the zero of the vernier scale. If they coincide then there is no zero error. If they do not coincide with each other, the instrument is said to possess zero error. Zero error may be positive or negative. If the zero of a vernier is shifted to the right of main scale, it is called positive error. On the other hand, if the zero of the vernier is shifted to the left of the zero of main scale, then the error is negative.

### Positive zero error

Figure 1.3 shows the positive zero error. From the figure you can see that zero of the vernier scale is shifted to the right of the zero of the main scale. In this case the reading will be more than the actual reading. Hence, this error should be corrected. In order to correct this error, find out which vernier division is coinciding with any of the main scale divisions. Here, fifth vernier division is coinciding with a main scale division. So, positive zero error =  $+5 \times LC = +5 \times 0.01 = 0.05$  cm and the zero correction is negative. Hence, zero correction is  $-0.05$  cm.

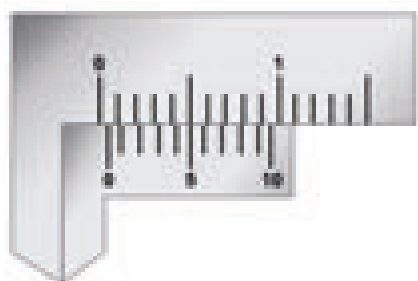

Figure 1.3 Positive zero error

#### Problem 1

Calculate the correct reading, if the main scale reading is 8 cm, vernier coincidence is 4 and positive zero error is 0.05 cm.

#### Solution:

$$\begin{aligned} \text{Correct reading} &= 8 \text{ cm} + (4 \times 0.01 \text{ cm}) - 0.05 \text{ cm} \\ &= 8 + 0.04 - 0.05 = 8 - 0.01 = 7.99 \text{ cm} \end{aligned}$$

### Negative zero error

Now look at the Figure 1.4. You can see that the zero of the vernier scale is shifted to the

left of the zero of the main scale. So, the obtained reading will be less than the actual reading. To correct this error we should first find which vernier division is coinciding with any of the main scale divisions, as we found in the previous case. In this case, you can see that sixth line is coinciding. To find the negative error, we can count backward (from 10). Here, the fourth line is coinciding. Therefore, negative zero error =  $-4 \times LC = -4 \times 0.01 = -0.04$  cm. Then zero correction is positive. Hence, zero correction is  $+0.04$  cm.

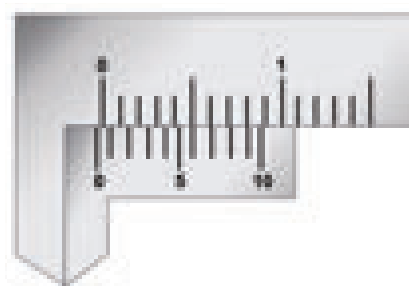

Figure 1.4 Negative zero error

#### Problem 2

The main scale reading is 8 cm and vernier coincidence is 4 and negative zero error is 0.02 cm. Then calculate the correct reading:

#### Solution:

$$\begin{aligned} \text{Correct reading} &= 8 \text{ cm} + (4 \times 0.01 \text{ cm}) + (0.02 \text{ cm}) \\ &= 8 + 0.04 + 0.02 = 8.06 \text{ cm}. \end{aligned}$$

We can use Vernier caliper to find different dimensions of any familiar object. If the length, width and height of the object can be measured, volume can be calculated. For example, if we could measure the inner diameter of a beaker (using appropriate jaws) as well as its depth (using the depth probe) we can calculate its inner volume.

#### Activity 1

Using Vernier caliper find the outer diameter of your pen cap.



### 1.6.3 Digital Vernier caliper

We are living in a digital world and the digital version of the vernier callipers are available nowadays. Digital Vernier caliper (Figure 1.5) has a digital display on the slider, which calculates and displays the measured value. The user need not manually calculate the least count, zero error etc.

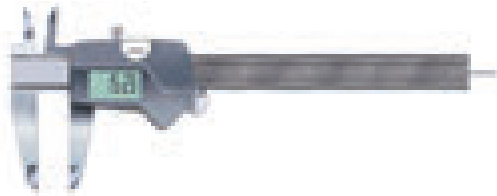

Figure 1.5 Digital Vernier caliper

## 1.7 Screw Gauge

Screw gauge is an instrument that can measure the dimensions upto  $1/100^{\text{th}}$  of a millimetre or 0.01 mm. With the screw gauge it is possible to measure the diameter of a thin wire and thickness of thin metallic plates.

### 1.7.1 Description of screw gauge

The screw gauge consists of a U shaped metal frame. A hollow cylinder is attached to one end of the frame. Grooves are cut on the inner surface of the cylinder through which a screw passes (Figure 1.6). On the cylinder parallel to the axis of the screw there is a scale which is graduated in millimetre. It is called Pitch Scale (PS). One end of the screw is attached to a sleeve. The head of the sleeve (Thimble) is divided into 100 divisions and it is called the Head scale.

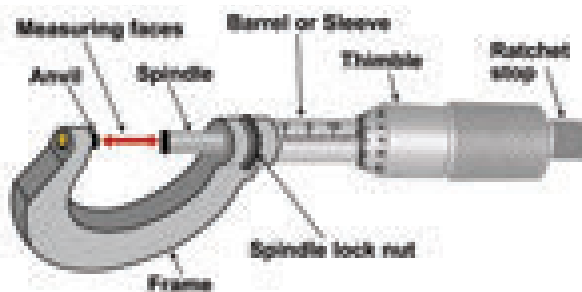

Figure 1.6 Screw gauge

The end of the screw has a plane surface (Spindle). A stud (Anvil) is attached to the other end of the frame, just opposite to the tip of the screw. The screw head is provided with a ratchet arrangement (safety device) to prevent the user from exerting undue pressure.

### 1.7.2 Using the screw gauge

The screw gauge works on the principal that when a screw rotates in a nut, the distance moved by the tip of the screw is directly proportional to the number of rotations.

#### a) Pitch of the screw

The pitch of the screw is the distance moved by the tip of the screw for one complete rotation of the head.



It is equal to 1 mm in typical screw gauges.

$$\text{Pitch of the screw} = \frac{\text{Distance moved by the Pitch}}{\text{No. of rotations by Head scale}}$$

#### b) Least count of a screw gauge

The distance moved by the tip of the screw for a rotation of one division on the head scale is called the least count of the screw gauge.

$$\begin{aligned} \text{Least count of the instrument (L.C.)} \\ = \frac{\text{Value of one smallest pitch scale reading}}{\text{Total number of Head scale division}} \end{aligned}$$

$$\text{LC} = \frac{1}{100} = 0.01 \text{ mm}$$

#### c) Zero Error of a screw gauge

When the movable stud of the screw and the opposite fixed stud on the frame area brought into contact, if the zero of the head scale coincides with the pitch scale axis there is no zero error.

#### Positive zero error

When the movable stud of the screw and the opposite fixed stud on the frame are brought into contact, if the zero of the head scale lies below the pitch scale axis, the zero error is



positive (Figure 1.7). Here, the 5th division of the head scale coincides with the pitch scale axis. Then the zero error is positive and is given by,

$Z.E = + (n \times LC)$  where 'n' is the head scale coincidence. In this case, Zero error =  $+ (5 \times 0.01) = 0.05\text{mm}$ . So the zero correction is  $- 0.05 \text{ mm}$ .

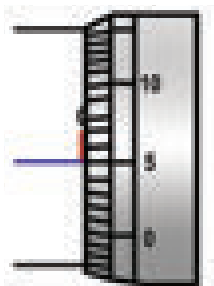

**Figure 1.7** Positive Zero Error

### Negative zero error

When the plane surface of the screw and the opposite plane stud on the frame are brought into contact, if the zero of the head scale lies above the pitch scale axis, the zero error is negative (Figure 1.8). Here, the 95<sup>th</sup> division coincides with the pitch scale axis. Then the zero error is negative and is given by,

$$\begin{aligned} Z.E &= - (100 - n) \times LC \\ Z.E &= - (100 - 95) \times LC \\ &= - 5 \times 0.01 \\ &= - 0.05 \text{ mm} \end{aligned}$$

The zero correction is  $+ 0.05\text{mm}$ .

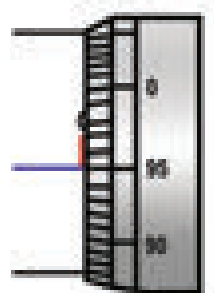

**Figure 1.8** Negative Zero Error

### Activity 2

Determine the thickness of a single sheet of your science textbook with the help of a Screw gauge.

## 1.8 Measuring Mass

We commonly use the term 'weight' which is actually the 'mass'. Many things are measured in terms of 'mass' in the commercial world. The SI unit of mass is kilogram (kg). In any case, the units are based on the items purchased. For example, we buy gold in gram or milligram, medicines in milligram, provisions in gram and kilogram and express cargo in tonnes.

Can we use the same instrument for measuring the above listed items? Different measuring devices have to be used for items of smaller and larger masses. In this section we will study about some of the instruments used for measuring mass.



The shell of an egg is 12% of its mass. A blue whale can weigh as much as 30 elephants and it is as long as 3 large tour buses.

### Common (beam) balance

A beam balance compares the sample mass with a standard reference mass (Standard reference masses are 5g, 10g, 20g, 50g, 100g, 200g, 500g, 1kg, 2kg, 5kg). This balance can measure mass accurately up to 5g (Figure 1.9).



**Figure 1.9** Common beam balance

### Physical balance

This balance is used in labs and is similar to the beam balance but it is a lot more sensitive and can measure mass of an object correct to a milligram (Figure 1.10).

The standard reference masses used in this physical balance are 10 mg, 20 mg, 50 mg, 100 mg, 200 mg, 500 mg, 1 g, 2 g, 5 g, 10 g, 20 g, 50 g, 100g, and 200 g.



Figure 1.10 Physical balance

### Digital balance

Nowadays, for accurate measurements digital balances are used, which measure mass accurately even up to a few milligrams, the least value being 10 mg (Figure 1.11). This electrical device is easy to handle and commonly used in jewellery shops and labs.



Figure 1.11 Digital balance

### Activity 3

With the resources such as paper plates, tea cups, thread and sticks available at home make a model of an ordinary balance. Using standard masses find the mass of some objects.

### Spring balance

This balance helps us to find the weight of an object. It consists of a spring fixed at one end and a hook attached to a rod at the other end. It works by 'Hooke's law' which states that the addition of weight produces a proportional increase in the length of the spring (Figure 1.12). A pointer is

attached to the rod which slides over a graduated scale on the right. The spring extends according to the weight attached to the hook and the pointer reads the weight of the object on the scale.

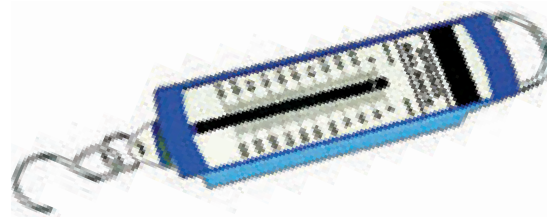

Figure 1.12 Spring balance

### 1.8.1 Difference between mass and weight

Mass ( $m$ ) is the quantity of matter contained in a body. Weight ( $w$ ) is the normal force ( $N$ ) exerted by the surface on the body to balance against gravitational pull on the object. In the case of spring scale, the tension in the spring balances the gravitational pull on the object. When a man is standing on the surface of the earth or floor, the surface exerts a normal force on the body which is equivalent to gravitational force. The gravitational force acting on the object is given by 'mg'. Here,  $m$  is mass of the object and 'g' is acceleration due to gravity.

#### Problem 3

If a man has a mass 50 kg on the earth, then what is his weight?

#### Solution:

$$\begin{aligned} \text{Weight } (w) &= mg \\ \text{Mass of a man} &= 50 \text{ kg} \\ \text{His weight} &= 50 \times 9.8 \\ w &= 490 \text{ newton} \end{aligned}$$

The pull of gravity on the Moon is 1/6 times weaker than that on the Earth. This causes the weight of the object on the Moon to be less than that on the Earth by six times. Acceleration due to gravity on the Moon =  $1.63 \text{ ms}^{-2}$

If the mass of a man is 70 kg then his weight on the Earth is 686 N and on the Moon is 114 N. But his mass is still 70 kg on the Moon.



Mass	Weight
1. It is a fundamental quantity.	It is a derived quantity.
2. It has magnitude alone – scalar quantity.	It has magnitude and direction – vector quantity.
3. It is the amount of matter contained in a body.	It is the normal force exerted by the surface on the object against gravitational pull.
4. Remains the same everywhere.	Varies from place to place.
5. It is measured using physical balance.	It is measured using spring balance.
6. Its unit is kilogram.	Its unit is newton.

## 1.9 Accuracy in Measurements

When measuring physical quantities, accuracy is important. Accuracy represents how close a measurement comes to a true value. Accuracy in measurement is center in engineering, physics and all branches of science. It is also important in our daily life. You might have seen in jewellery shops how accurately they measure gold. What will happen if little more salt is added to food while cooking? So, it is important to be accurate when taking measurements.

Faulty instruments and human error can lead to inaccurate values. In order to get accurate values of measurement, it is always important to check the correctness of the measuring instruments. Also, repeating the measurement and getting the average value can correct the errors and give us accurate value of the measured quantity.

### Points to Remember

- ❖ Quantities which cannot be expressed in terms of any other physical quantities are called fundamental quantities. Example: Length, mass, time, temperature etc.
- ❖ Quantities which can be expressed in terms of fundamental quantities are

called derived quantities. Example: Area, volume and density etc.

- ❖ A unit is the fundamental quantity with which unknown quantities are compared.
- ❖ Length, mass, time, temperature, electric current, intensity and mole are the fundamental units in SI system.
- ❖ To find the length or thickness of smaller dimensions Vernier caliper and Screw gauge are used.
- ❖ Astronomical unit is the mean distance of the Sun from the center of the Earth.  $1\text{AU}=1.496 \times 10^{11}\text{m}$ .
- ❖ Light year is the distance travelled by light in one year in vacuum.  $1\text{ Light year} = 9.46 \times 10^{15}\text{m}$ .
- ❖ Parsec is the unit of distance used to measure astronomical objects outside the solar system.
- ❖  $1\text{ Angstrom (A}^\circ) = 10^{-10}\text{ m}$ .
- ❖ SI Unit of volume is cubic metre or  $\text{m}^3$ . Generally volume is represented in litre (l).  $1\text{ml}=1\text{cm}^3$ .
- ❖ Least count of screw gauge is 0.01 mm. Least count of Vernier caliper is 0.01 cm.
- ❖ Common balance can measure mass accurately upto 5 g.
- ❖ Accuracy of physical balance is 10 mg.

## A-Z GLOSSARY

<b>Metre [m]</b>	Distance light travels, in a vacuum, in $1/299792458^{\text{th}}$ of a second.
<b>Kilogram [kg]</b>	Mass of an international prototype in the form of a platinum-iridium cylinder kept at Sevres in France.
<b>Second [s]</b>	Length of time taken for 9192631770 periods of vibration of the Caesium-133 atom to occur.
<b>Ampere [A]</b>	It is that current which produces a specified force between two parallel wires which are 1 metre apart in a vacuum.
<b>Kelvin [K]</b>	It is $1/273.16^{\text{th}}$ of the thermodynamic temperature of the triple point of water.
<b>Mole [mol]</b>	Amount of the substance that contains as many elementary units as there are atoms in 0.012 kg of carbon-12.
<b>Candela [cd]</b>	Intensity of a source of light of a specified frequency, which gives a specified amount of power in a given direction.



## TEXTBOOK EXERCISES

### I. Choose the correct answer.

1. Choose the correct one.

- $\text{mm} < \text{cm} < \text{m} < \text{km}$
- $\text{mm} > \text{cm} > \text{m} > \text{km}$
- $\text{km} < \text{m} < \text{cm} < \text{mm}$
- $\text{mm} > \text{m} > \text{cm} > \text{km}$



2. Rulers, measuring tapes and metre scales are used to measure

- mass
- weight
- time
- length

3. 1 metric ton is equal to

- 100 quintals
- 10 quintals
- $1/10$  quintals
- $1/100$  quintals

4. Which among the following is not a device to measure mass?

- Spring balance
- Beam balance
- Physical balance
- Digital balance

### II. Fill in the blanks.

- Metre is the unit of \_\_\_\_\_
- 1 kg of rice is weighed by \_\_\_\_\_

3. Thickness of a cricket ball is measured by \_\_\_\_\_

4. Radius of a thin wire is measured by \_\_\_\_\_

5. A physical balance measures small differences in mass up to \_\_\_\_\_

### III. State whether true or false. If false, correct the statement.

- The SI unit of electric current is kilogram.
- Kilometre is one of the SI units of measurement.
- In everyday life, we use the term weight instead of mass.
- A physical balance is more sensitive than a beam balance.
- One Celsius degree is an interval of 1K and zero degree Celsius is 273.15 K.
- With the help of vernier caliper we can have an accuracy of 0.1 mm and with screw gauge we can have an accuracy of 0.01 mm.



#### IV. Match the following.

- |                 |                |
|-----------------|----------------|
| 1. Length       | kelvin         |
| Mass            | metre          |
| Time            | kilogram       |
| Temperature     | second         |
| 2. Screw gauge  | Vegetables     |
| Vernier caliper | Coins          |
| Beam balance    | Gold ornaments |
| Digital balance | Cricket ball   |

#### V. Assertion and reason type questions.

Mark the correct answer as:

- Both A and R are true but R is not the correct reason.
  - Both A and R are true and R is the correct reason.
  - A is true but R is false.
  - A is false but R is true.
- Assertion(A): The scientifically correct expression is “The mass of the bag is 10 kg”  
Reason (R): In everyday life, we use the term weight instead of mass.
  - Assertion (A):  $0\text{ }^{\circ}\text{C} = 273.16\text{ K}$ . For our convenience we take it as 273 K after rounding off the decimal.  
Reason (R): To convert a temperature on the Celsius scale we have to add 273 to the given temperature.
  - Assertion (A): Distance between two celestial bodies is measured in terms of light year.  
Reason (R): The distance travelled by the light in one year is one light year.

#### VI. Answer very briefly.

- Define measurement.
- Define standard unit.
- What is the full form of SI system?

- Define least count of any device.
- What do you know about pitch of screw gauge?
- Can you find the diameter of a thin wire of length 2 m using the ruler from your instrument box?

#### VII. Answer briefly.

- Write the rules that are followed in writing the symbols of units in SI system.
- Write the need of a standard unit.
- Differentiate mass and weight.
- How will you measure the least count of vernier caliper?

#### VIII. Answer in detail.

- Explain a method to find the thickness of a hollow tea cup.
- How will you find the thickness of a one rupee coin?

#### IX. Numerical Problems.

- Inian and Ezhilan argue about the light year. Inian tells that it is  $9.46 \times 10^{15}\text{ m}$  and Ezhilan argues that it is  $9.46 \times 10^{12}\text{ km}$ . Who is right? Justify your answer.
- The main scale reading while measuring the thickness of a rubber ball using Vernier caliper is 7 cm and the Vernier scale coincidence is 6. Find the radius of the ball.
- Find the thickness of a five rupee coin with the screw gauge, if the pitch scale reading is 1 mm and its head scale coincidence is 68.
- Find the mass of an object weighing 98 N.



## REFERENCE BOOKS

1. Units and Measurements – John Richards. S. Chand publishing, Ram nagar, New Delhi.
2. Complete physics (IGCSE) - Oxford University press, New York.
3. Practical physics – Jerry. D. Wilson – Saunders college publishing, USA.

## INTERNET RESOURCES

- <http://www.npl.co.uk/reference/measurement-units/>
- <http://www.splung.com/content/sid/1/page/units>
- [http://www.edinformatics.com/math\\_science/units.htm](http://www.edinformatics.com/math_science/units.htm)
- <https://www.unc.edu/~rowlett/units/dictA.html>
- <https://study.com/academy/lesson/standard-units-of-measure.html>

### Concept Map

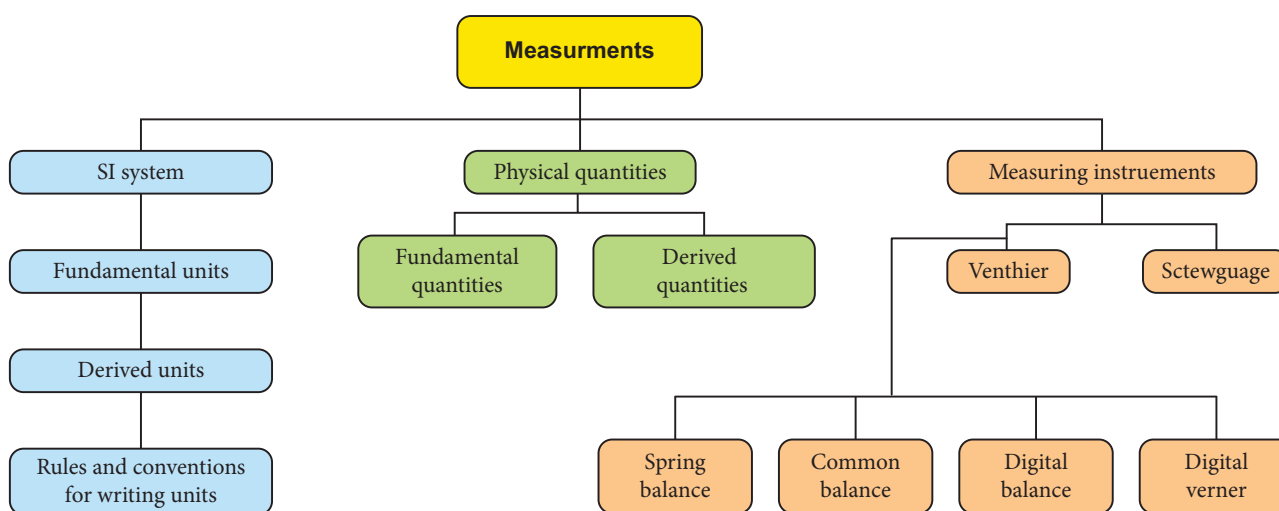

### ICT CORNER

#### MEASUREMENT - VERNIER CALIPER

Vernier is a visual aid that helps the user to measure the internal and external diameter of the object.

This activity helps the students to understand the usage better

**Step 1.** Type the following URL in the browser or scan the QR code from your mobile. You can see “Vernier caliper” on the screen.

**Step 2.** The yellow colour scale is movable. Now you can drag and keep the blue colour cylinder in between. Now you can measure the dimension of the cylinder. Use the + symbol to drag cylinder and scale.

**Step 3.** Now go to the place where you can enter your answer. An audio gives you the feedback and you can see the answer on the screen also

<https://play.google.com/store/apps/details?id=com.ionicframework.vernierapp777926>



B567\_9\_SCI\_EM\_T3

 Learning Objectives

After completing this lesson, students will be able to:

- list the objects which are at rest and which are in motion.
- understand distance and displacement.
- determine the distance covered by an object describing a circular path.
- classify uniform motion and non-uniform motion.
- distinguish between speed and velocity.
- relate accelerated and unaccelerated motion.
- deduce the equations of motion of an object from velocity – time graph.
- write the equations of motion for a freely falling body.
- understand the nature of circular motion.
- identify centripetal force and centrifugal force in day to day life.

**Introduction**

Motion is the change in the position of an object with respect to its surrounding. Everything in the universe is in motion. Even though an object seems to be not moving, actually it is moving because the Earth is moving around the Sun. You may see objects moving in your surrounding. Cars along the road, trains along the track and aeroplanes in the sky are all moving. These movements are one type of motion. You may see the fan rotating in the ceiling. This is another type of motion. When you are playing in swing, it moves to and fro. This is also a type of motion. Motion is described in terms of distance, speed, acceleration and time. In this lesson we will study about different types and equations of motion, displacement, velocity and acceleration.

**2.1 Rest and Motion** **Activity 1**

Look around you. You can see many things: a row of houses, large trees, small plants, flying birds, running cars and many more. List the objects which remain fixed at their position and the objects which keep on changing their position.

In physics, the objects which do not change their position are said to be at rest, while those which change their position are said to be in motion. For example, a book lying on a table and the walls of a room are at rest. Cars and buses running on the road, birds and aeroplanes flying in air are in motion. Motion is a relative phenomenon. This means that an

object appearing to be in motion to one person can appear to be at rest as viewed by another person. For example, trees on road side would appear to move backward for a person travelling in a car while the same tree would appear to be at rest for a person standing on the road side.

## 2.2 Types of Motion

In physics, motion can be classified as below.

**Linear motion:** Motion along a straight line.

**Circular motion:** Motion along a circular path.

**Oscillatory motion:** Repetitive to and fro motion of an object at regular interval of time.

**Random motion:** Motion of the object which does not fall in any of the above categories.

### 2.2.1 Uniform and Non-uniform motion

#### Uniform motion

Consider a car which covers 60 km in the first hour, 60 km in the second hour, and another 60 km in the third hour and so on. The car covers equal distance at equal interval of time. We can say that the motion of the car is uniform.

An object is said to be in uniform motion if it covers equal distances in equal intervals of time howsoever big or small these time intervals may be.

#### Non-uniform motion

Now, consider a bus starting from one stop. It proceeds slowly when it passes through crowded area of the road. Suppose, it manages to travel merely 100 m in 5 minutes due to heavy traffic and is able to travel about 2 km in 5 minutes when the road is clear. Hence, the motion of the bus is non-uniform i.e. it travels unequal distances in equal intervals of time.



Thus, an object is said to be in non-uniform motion if it covers unequal distances in equal intervals of time.

### Activity 2

Tabulate the distance covered by a bus in a heavy traffic road in equal intervals of time and do the same for a train which is not in an accelerated motion. From your table what do you understand?

The bus covers unequal distance in equal intervals of time but the train covers equal distances in equal intervals of time.

## 2.3 Distance and Displacement

Consider a body moving from the point A. It moves along the path given in the Figure 2.1 and reaches the point B. The total length of the path travelled by the body from A to B is called distance travelled by the body. The length of the straight line AB is called displacement of the body.

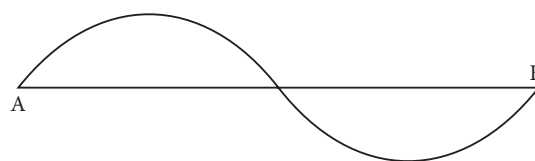

Figure 2.1 Distance and Displacement

### 2.3.1 Distance

The actual length of the path travelled by a moving body irrespective of the direction is called the distance travelled by the body. It is measured in metre in SI system. It is a scalar quantity having magnitude only.

### 2.3.2 Displacement

It is defined as the change in position of a moving body in a particular direction. It is a vector quantity having both magnitude and direction. It is also measured in metre in SI system.



### Activity 3

Observe the motion of a car as shown in the figure and answer the following questions:

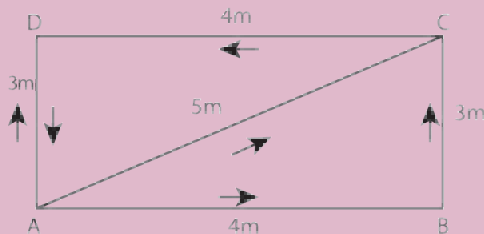

Compare the distance covered by the car through the path ABC and AC. What do you observe? Which path gives the shortest distance to reach D from A? Is it the path ABCD or the path ACD or the path AD?

## 2.4 Speed, Velocity and Acceleration

Speed is the quantity which shows how fast the body is moving but velocity is the quantity which shows the speed as well as the direction of the moving body.

### 2.4.1 Speed

Speed is the rate of change of distance or the distance travelled in unit time. It is a scalar quantity. The SI unit of speed is  $\text{ms}^{-1}$ .  
Speed = Distance travelled / Time taken

#### Problem 1

An object travels 16 m in 4 s and then another 16 m in 2 s. What is the average speed of the object?

#### Solution:

Total distance travelled by the object = 16 m + 16 m = 32 m

Total time taken = 4s + 2s = 6s

$$\text{Average speed} = \frac{\text{Total distance travelled}}{\text{Total time taken}} = \frac{32\text{m}}{6\text{s}} = 5.33 \text{ ms}^{-1}$$

Therefore, the average speed of the object is  $5.33 \text{ ms}^{-1}$

#### Problem 2

A sound is heard 5 s later than the lightning is seen in the sky on a rainy day. Find the distance of location of lightning? Given the speed of sound =  $346 \text{ ms}^{-1}$

#### Solution:

$$\text{Speed} = \frac{\text{Distance}}{\text{Time}}$$

$$\text{Distance} = \text{Speed} \times \text{Time} = 346 \times 5 = 1730 \text{ m}$$

Thus, the distance of location of lightning is 1730 m.

### 2.4.2 Velocity

Velocity is the rate of change of displacement. It is the displacement in unit time. It is a vector quantity. The SI unit of velocity is  $\text{ms}^{-1}$ .



$$\text{Velocity} = \text{Displacement} / \text{Time taken}$$

### 2.4.3 Acceleration

Acceleration is the rate of change of velocity or it is the change of velocity in unit time. It is a vector quantity. The SI unit of acceleration is  $\text{ms}^{-2}$ .

Acceleration

$$= \text{Change in velocity} / \text{Time}$$

$$= (\text{Final velocity} - \text{Initial velocity}) / \text{Time}$$

$$a = (v - u) / t$$

Consider a situation in which a body moves in a straight line without reversing its direction. From the above equation if  $v > u$ , i.e. if final velocity is greater than initial velocity, the velocity increases with time and the value of acceleration is positive.

If  $v < u$ , i.e. if final velocity is less than initial velocity, the velocity decreases with time and the value of acceleration is negative. It is called negative acceleration. Negative acceleration is called retardation or deceleration. If the acceleration has a value of  $-2 \text{ ms}^{-2}$ , we say that deceleration is  $2 \text{ ms}^{-2}$ .

## 2.5 Graphical representation of motion along a straight line

Plotting the distance/displacement or speed/velocity on a graph helps us to understand certain things about time and position.

### 2.5.1 The distance – time graph for Uniform motion

Consider the Table 2.1 which shows the distance walked by a person at different times.

**Table 2.1** Uniform motion

Time (minute)	Distance (metre)
0	0
5	500
10	1000
15	1500
20	2000
25	2500

A graph is drawn by taking time along X-axis and distance along Y-axis. The graph is known as distance – time graph.

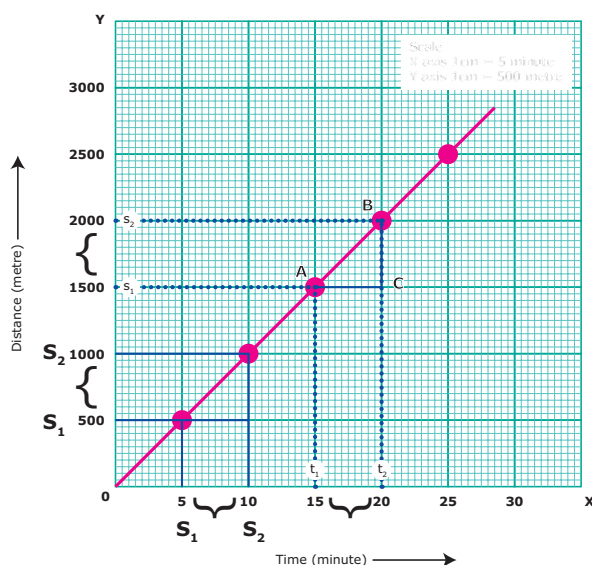

**Figure 2.2** The distance – time graph for Uniform motion

When we look at the distance – time graph, we notice few things. First, it is a

straight line. We also notice that the person covers equal distances in equal intervals of time. We can therefore conclude that he walked at a constant speed. Can you find the speed at which he walked, from the graph? Yes, you can. The parameter is referred as the slope of the line.

$$\begin{aligned} \text{Speed} &= \text{Distance covered} / \text{Time taken} \\ &= \text{Slope of the straight line} \\ &= BC/AC \text{ (From the graph)} \\ &= 500 / 5 = 100 \text{ m/min} \end{aligned}$$

Steeper the slope (in other words the larger value) the greater is the speed.

Let us take a look at the distance – time graphs of three different people – Asher walking, Saphira cycling and Kanishka going in a car, along the same path (Fig 2.3). We know that cycling can be faster than walking and a car can go faster than a cycle. The distance – time graph of the three would be as given in the following graph. The slope of the line on the distance – time graph becomes steeper and steeper as the speed increases.

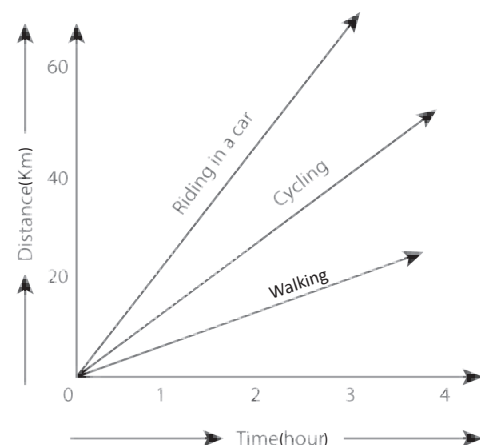

**Figure 2.3** Comparison of speed

### 2.5.2 The distance time graph for Non-uniform motion

We can also plot the distance – time graph for accelerated motion (non-uniform motion). Table 2.2 shows the distance travelled by a car in a time interval of two seconds.

**Table 2.2** Non-uniform motion

Time (second)	Distance (metre)
0	0
2	1
4	4
6	9
8	16
10	25
12	36

If we plot a graph between the distance travelled and the time taken, it would be as shown in Figure 2.4.

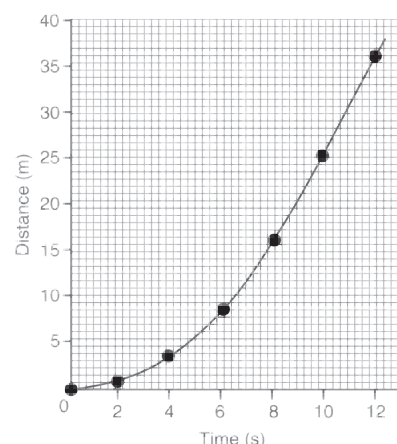

**Figure 2.4** The distance time graph for Non-uniform motion

Note that the graph is not a straight line as we got in the case of uniform motion. This nature of the graph shows non-linear variation of the distance travelled by the car with time. Thus, the graph represents motion with non-uniform speed.

### 2.5.3 Velocity – Time graph

The variation in velocity of an object with time can be represented by velocity – time graph. In the graph, time is represented along the X – axis and the velocity is represented along the Y – axis. If the object moves at uniform velocity, a straight line parallel to X-axis is obtained. This graph shows the velocity – time graph for a car moving with uniform velocity of 40 km/hour.

We know that the product of velocity and time gives displacement of an object

moving with uniform velocity. Thus, the area under the velocity – time graph is equal to the magnitude of the displacement. So, the distance (displacement),  $S$  covered by the car in a time interval of  $t$  can be expressed as,

$$S = AC \times CD$$

$S = \text{Area of the rectangle } ABCD \text{ (shaded portion in the graph)}$

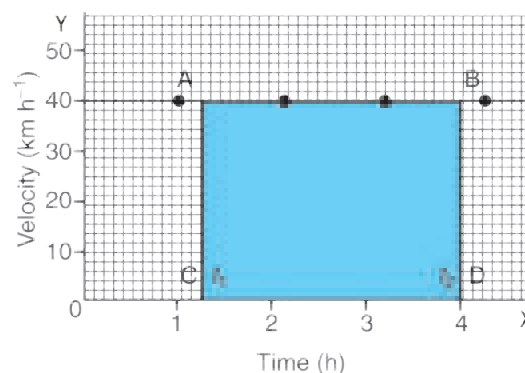

**Figure 2.5** Velocity – Time graph

We can also study about uniformly accelerated motion by plotting its velocity – time graph. Consider a car being driven along a straight road. Its velocity for every 5 seconds is noted from the speedometer of the car. The velocity of the car in  $\text{ms}^{-1}$  at different instants of time is shown in the Table 2.3.

**Table 2.3** Uniformly accelerated motion

Time (Second)	Velocity of the Car ( $\text{ms}^{-1}$ )
0	0
5	9
10	18
15	27
20	36
25	45
30	54

In this case, the velocity – time graph for the motion of the car is shown in Figure 2.6 (straight line). The nature of the graph shows that the velocity changes by equal amounts in equal intervals of time. Thus, for all uniformly accelerated motion, the velocity – time graph is a straight line.

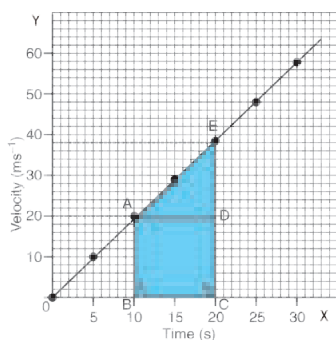

**Figure 2.6** Velocity – Time graph for uniform acceleration

One can also determine the distance moved by the car from its velocity – time graph. The area under the velocity – time graph gives the distance (magnitude of displacement) moved by the car in a given interval of time.

Since the magnitude of the velocity of the car is changing due to acceleration, the distance,  $S$  travelled by the car will be given by the area ABCDE under the velocity – time graph. That is,

$$S = \text{Area ABCDE} \\ = \text{Area of the rectangle ABCD} + \text{Area of the triangle ADE}$$

$$S = (AB \times BC) + \frac{1}{2} (AD \times DE)$$

Area of the quadrangle ABCDE can also be calculated by calculating the area of trapezium ABCDE. It means,

$$S = \text{Area of trapezium ABCDE} \\ = \frac{1}{2} \times \text{Sum of length of parallel sides} \\ \times \text{Distance between parallel sides} \\ S = \frac{1}{2} \times (AB + CE) \times BC$$

In the case of non-uniformly accelerated motion, distance – time graph and velocity – time graphs can have any shape as shown in Figure 2.7.



The speedometer of an automobile measures the instantaneous speed of the automobile. In a uniform motion in one dimension, the average velocity is equal to instantaneous velocity. Instantaneous velocity is also called velocity or instantaneous speed or simply speed.

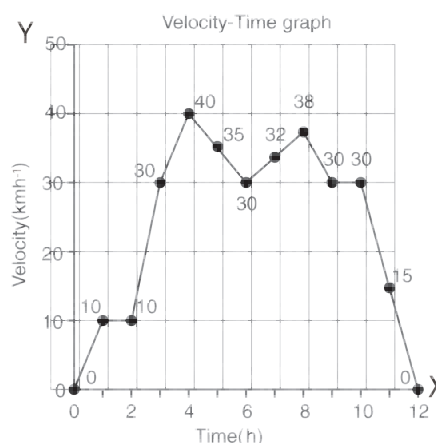

**Figure 2.7** Velocity – Time graph for Non-uniform acceleration

## 2.6 Equations of Motion

Newton studied the motion of an object and gave a set of three equations. These equations relate displacement, velocity, acceleration and time of an object under motion. An object in motion with initial velocity,  $u$  attains a final velocity,  $v$  in time,  $t$  due to acceleration,  $a$  and reaches a distance,  $s$ . Three equations can be written for this motion.

$$v = u + at$$

$$s = ut + \frac{1}{2} a t^2$$

$$v^2 = u^2 + 2as$$

Let us try to derive these equations by graphical method.

Figure 2.8 shows the change in velocity with time for an uniformly accelerated object. The object starts from the point D in the graph with velocity,  $u$ . Its velocity keeps increasing and after time,  $t$  it reaches the point B on the graph.

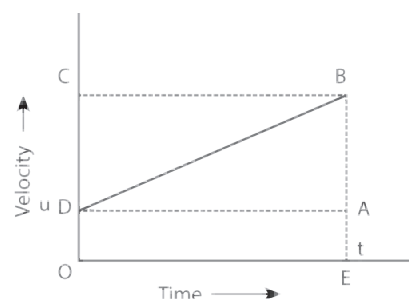

**Figure 2.8** Equations of Motion

The initial velocity of the object =  $u = OD = EA$   
The final velocity of the object =  $v = OC = EB$



$$\text{Time} = t = \text{OE} = \text{DA}$$

From the graph we know that,  $\text{AB} = \text{DC}$

### First equation of motion

$$\begin{aligned} \text{By definition, Acceleration} \\ &= \text{Change in velocity} / \text{Time} \\ &= (\text{Final velocity} - \text{Initial velocity}) / \text{Time} \\ &= (\text{OC} - \text{OD}) / \text{OE} \\ &= \text{DC} / \text{OE} \\ a &= \text{DC} / t \end{aligned}$$

$$\text{DC} = \text{AB} = at$$

From the graph  $\text{EB} = \text{EA} + \text{AB}$

$$v = u + at \quad (1)$$

This is the first equation of motion.

### Second equation of motion

From the graph the distance covered by the object during time,  $t$  is given by the area of quadrangle DOEB

$$\begin{aligned} s &= \text{Area of the quadrangle DOEB} \\ &= \text{Area of the rectangle DOEA} + \text{Area of the triangle DAB} \\ &= (\text{AE} \times \text{OE}) + (1/2 \times \text{AB} \times \text{DA}) \\ s &= ut + \frac{1}{2} at^2 \quad (2) \end{aligned}$$

This is the second equation of motion.

### Third equation of motion

We see that the distance covered by the object during time,  $t$  is given by the area of the quadrangle DOEB. Here, DOEB is a trapezium. Then,

$$\begin{aligned} s &= \text{Area of trapezium DOEB} \\ &= \frac{1}{2} \times \text{Sum of length of parallel side} \times \\ &\quad \text{Distance between parallel sides} \\ &= \frac{1}{2} \times (\text{OD} + \text{BE}) \times \text{OE} \\ s &= \frac{1}{2} \times (u + v) \times t \end{aligned}$$

Since,  $a = (v - u) / t$  or  $t = (v - u) / a$

$$\begin{aligned} s &= \frac{1}{2} \times (v + u) \times (v - u) / a \\ 2as &= v^2 - u^2 \\ v^2 &= u^2 + 2as \quad (3) \end{aligned}$$

This is the third equation of motion.

### Problem 3

The brakes applied to a car produce an acceleration of  $6 \text{ ms}^{-2}$  in the opposite direction to the motion. If the car takes 2 s to stop after the application of brakes, calculate the distance traveled during this time.

### Solution:

We have been given  $a = -6 \text{ ms}^{-2}$ ,  $t = 2 \text{ s}$  and  $v = 0$

From the equation of motion,

$$v = u + at$$

$$0 = u + (-6 \times 2)$$

$$0 = u - 12 \quad \therefore u = 12 \text{ ms}^{-1}$$

$$s = ut + \frac{1}{2} at^2$$

$$= (12 \times 2) + \frac{1}{2} (-6 \times 2 \times 2)$$

$$= 24 - 12 = 12 \text{ m}$$

Thus, the car will move 12 m before it stops after the application of brakes.

## 2.7 Motion of freely falling body

### Activity 4

Take a large stone and a small eraser. Stand on the top of a table and drop them simultaneously from the same height. What do you observe? Now, take a small eraser and a sheet of paper. Drop them simultaneously from the same height. What do you observe? This time, take two sheets of paper having same mass and crumple one of the sheets into a ball. Now, drop the sheet and the ball from the same height. What do you observe?

From Activity 4, you can observe that, both the stone and the eraser reach the surface of the earth almost at the same time. When you drop the eraser and paper, the eraser reaches first and the sheet of paper reaches later. You can also observe that the paper crumpled into a ball reaches ground first and plain sheet of paper reaches later, although they have equal mass. Do you know the



reason? When all these objects are dropped in the absence of air medium (vacuum), all would have reached the ground at the same time. In air medium, air offers some resistance to the motion of freely falling objects. But, it is negligibly small when compared to the gravitational pull acting on the stone and rubber. Hence, they reach the ground at the same time.

It can be seen from these activities that the magnitude of air resistance depends on the area of objects exposed to air. We know that an object experiences acceleration during free fall. This acceleration experienced by an object is independent of mass. This means that all objects hollow or solid, big or small, should fall at the same rate.

The equation of motion for a freely falling body can be obtained by replacing 'a' in equations with g, the acceleration due to gravity. For a freely falling body which is initially at rest,  $u = 0$ . Thus we get the following equations.

$$v = gt, s = \frac{1}{2}gt^2, v^2 = 2gh$$



Can a body have zero velocity and finite acceleration? Yes, when a body is thrown vertically upwards in space, at the highest point, the body has zero velocity but it has acceleration due to the gravity.

When we throw an object vertically upwards, it moves against the acceleration due to gravity. Hence, 'a' is taken to be  $-g$  and when moving downwards 'a' is taken as  $+g$ .

## 2.8 Uniform circular motion

### Activity 5

Take a piece of thread and tie a small piece of stone at one of its ends. Rotate the stone to describe a circular path with constant speed by holding the thread at the other end. Now, release the thread and let the stone go. Can you tell the direction in which the stone moves after it is released?

If you carefully observe, on being released the stone moves along a straight line tangential to the circular path. This is because once the stone is released, it continues to move along the direction it has been moving at that instant. This shows that the direction of motion changes at every point when the stone was moving along the circular path.

When an object is moving with a constant speed along a circular path, the velocity changes due to the change in direction. Hence, it is an accelerated motion. For example, revolution of earth around the sun, revolution of moon around the earth and the tip of the second's hand of a clock are all accelerated motions.

If an object, moving along a circular path of radius,  $r$  takes time,  $T$  to come back to its starting position, then the speed,  $v$  is given by,

$$\text{Speed} = \text{Circumference/Time taken}$$

$$V = \frac{2\pi r}{T}$$

## 2.9 Centripetal Acceleration and Centripetal Force

A body is said to be accelerated, if the velocity of the body changes either in magnitude or in direction. So, the motion of a stone in circular path with constant speed and continuous change of direction is an accelerated motion. In this case, there must be an acceleration acting along the string directed inwards, which makes the stone to move in circular path.

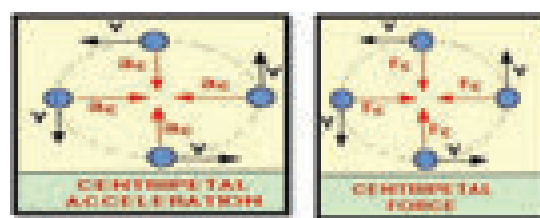

Figure 2.9 Centripetal acceleration and Centripetal force

This acceleration is known as centripetal acceleration and the force is known as centripetal force. Since the centripetal acceleration is directed radially towards the centre of the circle,

the centripetal force must act on the object radially towards the centre.

Let us consider an object of mass  $m$ , moving along a circular path of radius  $r$ , with a velocity,  $v$ . Its centripetal acceleration is given by

$$a = v^2 / r$$

The magnitude of centripetal force is given by,

$$F = \text{Mass} \times \text{Centripetal acceleration}$$

$$F = mv^2 / r$$

#### Problem 4

A 900 kg car moving at  $10 \text{ ms}^{-1}$  takes a turn around a circle with a radius of 25 m. Determine the acceleration and the net force acting upon the car.

#### Solution:

When the car turns around circle, it experiences centripetal acceleration,  $a = \frac{v^2}{r}$

$$a = \frac{(10)^2}{25} = \frac{100}{25} = 4 \text{ ms}^{-2}$$

Net force acting upon the car,

$$F = m a = 900 \times 4 = 3600 \text{ N}$$



Any force like gravitational force, frictional force, magnetic force, electrostatic force etc., may act as a centripetal force.

## 2.10 Centrifugal Force

### Activity 6

Take a piece of rope and tie a small stone at one end. Hold the other end of the rope and rotate it such that the stone follows a circular path.

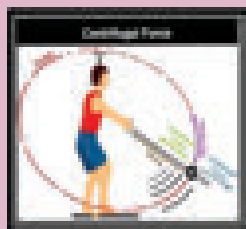

Do you experience any pull or push in your hand?

In this activity, a pulling force that acts away from the centre is experienced. This is called as centrifugal force. Force acting on a body away from the centre of circular path is called centrifugal force. Thus, centrifugal force acts in a direction which is opposite to the direction of centripetal force. Its magnitude is same as that of centripetal force. The dryer in a washing machine is an example for the application of centrifugal force.



When you go for a ride in a merry-go-round in amusement parks, you will experience an outward pull as merry-go round rotates about vertical axis. This is due to centrifugal force.

#### Points to Remember

- ❖ Motion is a change of position, which can be described in terms of the distance moved or the displacement.
- ❖ Motion of an object could be uniform or non-uniform depending on its velocity.
- ❖ Speed of an object is the distance covered per unit time and velocity is the displacement per unit time.
- ❖ The acceleration of an object is the change in velocity per unit time.
- ❖ The motion of an object at uniform acceleration can be described with the help of three equations, namely:
 
$$v = u + at; \quad s = ut + \frac{1}{2} at^2; \quad v^2 = u^2 + 2as$$
- ❖ For a freely falling body, the acceleration,  $a$  is replaced by  $g$ .
- ❖ An object under uniform circular motion experiences centripetal force.
- ❖ Centrifugal force acts in a direction which is opposite to the direction of the centripetal force.

## A-Z GLOSSARY

<b>Motion</b>	An object's change in its position.
<b>Distance</b>	Length an object has covered during its motion.
<b>Displacement</b>	Change in the position of an object measuring from its starting position to the final position only.
<b>Speed</b>	Rate of motion at which the object moves (distance/time).
<b>Velocity</b>	Speed of an object in a particular direction.
<b>Acceleration</b>	Change in magnitude or direction of velocity.
<b>Circular motion</b>	Movement of an object along the circumference of a circle or rotation along a circular path.
<b>Centripetal force</b>	Force which acts on a body moving in a circular path and directed towards the centre.
<b>Centrifugal force</b>	Force, arising from the body's inertia, which appears to act on a body moving in a circular path and is directed away from the centre.
<b>Gravity</b>	Force of attraction between an object and the centre of Earth, due to their masses.



## TEXTBOOK EXERCISES



### I. Choose the correct answer.

- The area under velocity – time graph represents the
  - velocity of the moving object.
  - displacement covered by the moving object.
  - speed of the moving object.
  - acceleration of the moving object.
- Which one of the following is most likely not a case of uniform circular motion?
  - Motion of the Earth around the Sun.
  - Motion of a toy train on a circular track.
  - Motion of a racing car on a circular track.
  - Motion of hours' hand on the dial of the clock.

- Which of the following graph represents uniform motion of a moving particle?

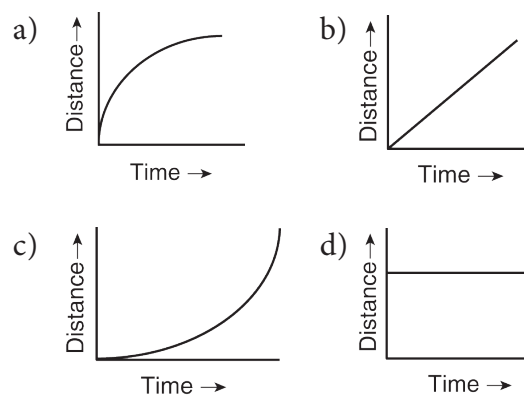

- The centrifugal force is
  - a real force.
  - the force of reaction of centripetal force.
  - a virtual force.
  - directed towards the centre of the circular path.

## II. Fill in the blanks.

- Speed is a \_\_\_\_\_ quantity whereas velocity is a \_\_\_\_\_ quantity.
- The slope of the distance – time graph at any point gives \_\_\_\_\_
- Negative acceleration is called \_\_\_\_\_
- Area under velocity – time graph shows \_\_\_\_\_

## III. State whether true or false. If false, correct the statement.

- The motion of a city bus in a heavy traffic road is an example for uniform motion.
- Acceleration can get negative value also.
- Distance covered by a particle never becomes zero but displacement becomes zero.
- The velocity – time graph of a particle falling freely under gravity would be a straight line parallel to the x axis.
- If the velocity – time graph of a particle is a straight line inclined to X-axis then its displacement – time graph will be a straight line.

## IV. Assertion and reason type questions.

Mark the correct choice as:

- If both assertion and reason are true and reason is the correct explanation of assertion.
- If both assertion and reason are true but reason is not the correct explanation of assertion.
- If assertion is true but reason is false.
- If assertion is false but reason is true.

- Assertion: The accelerated motion of an object may be due to change in magnitude of velocity or direction or both of them.

Reason: Acceleration can be produced only by change in magnitude of the velocity. It does not depend the direction.

- Assertion: The Speedometer of a car or a motor-cycle measures its average speed.  
Reason: Average velocity is equal to total displacement divided by total time taken.
- Assertion: Displacement of a body may be zero when distance travelled by it is not zero.  
Reason: The displacement is the shortest distance between initial and final position.

## V. Match the Following.

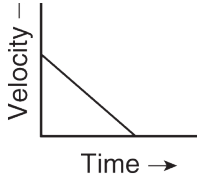
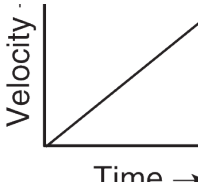
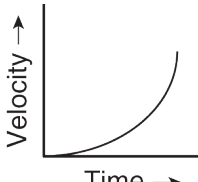
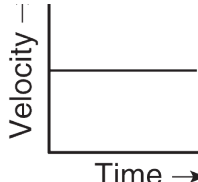
List I	List II
1. Motion of a body covering equal distances in equal interval of time	 A
2. Motion with non uniform acceleration	 B
3. Constant retardation	 C
4. Uniform acceleration	 D

## VI. Answer briefly.

- Define velocity.
- Distinguish distance and displacement.
- What do you mean by uniform motion?
- Compare speed and velocity.
- What do you understand about negative acceleration?
- Is the uniform circular motion accelerated? Give reasons for your answer.
- What is meant by uniform circular motion? Give two examples of uniform circular motion.

## VII. Answer in detail.

1. Derive the equations of motion by graphical method.
2. Explain different types of motion.

## VIII. Exercise Problems.

1. A ball is gently dropped from a height of 20 m. If its velocity increases uniformly at the rate of  $10 \text{ ms}^{-2}$ , with what velocity will it strike the ground? After what time will it strike the ground?
2. An athlete completes one round of a circular track of diameter 200 m in 40 s. What will be the distance covered and the displacement at the end of 2 m and 20 s?
3. A racing car has a uniform acceleration of  $4 \text{ ms}^{-2}$ . What distance it covers in 10 s after the start?



## REFERENCE BOOKS

1. Advanced Physics by: M. Nelkon and P. Parker, C.B.S publications, Chennai
2. College Physics by: R.L.Weber, K.V. Manning, Tata McGraw Hill, New Delhi.
3. Principles of Physics (Extended) - Halliday, Resnick & Walker, Wiley publication, New Delhi.



## INTERNET RESOURCES

[http://www.ducksters.com/science/physics/motion\\_glossary\\_and\\_terms.php](http://www.ducksters.com/science/physics/motion_glossary_and_terms.php)

<http://www.physicsclassroom.com/Class/1DKin/U1L1d.cfm>

<http://www.physicsclassroom.com/Class/1DKin/U1L1e.cfm>

<https://brilliant.org/wiki/uniform-circular-motion-easy/Centrifugal force>

## Concept Map

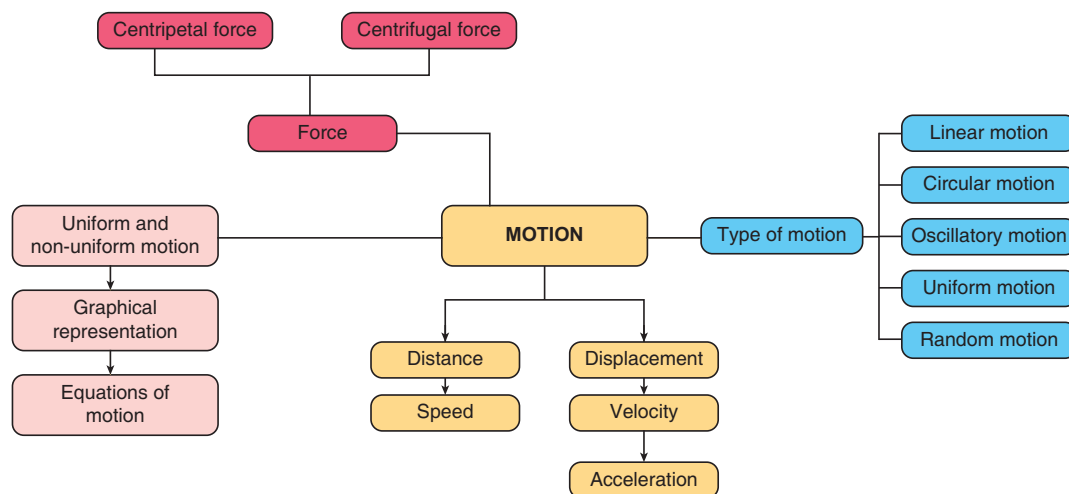

## ICT CORNER

## FORCE AND MOTION

Newton's second law says a force acting on the object either change its direction or acceleration or both.  $F=ma$

This activity proves that:

Step 1. Type the following URL in the browser or scan the QR code from your mobile. You can see a wheel barrow full of load on the screen. Below that you can see two sets of people also.

Step 2. Place different number of people on both the side of the rope. Click go. According to the force given by the people the wheel barrow moves to anyone of the side. If the number of people is equal on both the sides the load will not move.

Step 3. By changing the number of people you can see the force and motion.

<https://phet.colorado.edu/en/simulation/forces-and-motion-basics>



B567\_9\_SCI\_EM\_T3



## Learning Objectives

After completing this lesson, students will be able to

- define pressure in terms of weight.
- explain the variation of pressure with respect to depth in a fluid.
- learn the fact that liquid exerts an upward force on objects immersed in it.
- calculate the density of a liquid when pressure and altitude are given.
- learn the formula for finding the relative density of an object and apply the same.
- understand the behaviour of floating bodies.

## Introduction

A small iron nail sinks in water, whereas a huge ship of heavy mass floats on sea water. Astronauts have to wear a special suit while traveling in space. All these have a common reason called 'pressure'. If the pressure increases in a solid, based on its inherent properties, it experiences tension and ultimately deforms or breaks. In the case of fluids it causes them to flow rather than to deform. Although liquids and gases share some common characteristics, they have many distinctive characteristics on their own. It is easy to compress a gas whereas liquids are incompressible. Learning of all these facts helps us to understand pressure better. In this lesson you will study about pressure in fluids, density of fluids and their application in practical life.

### 3.1 Thrust and Pressure

Pushing a pin into a board by its head is difficult. But pushing it by the pointed end is easy. Why? Have you ever wondered

why a camel can run in a desert easily? Why a truck or a motorbus has wider tyre? Why cutting tools have sharp edges? In order to answer these questions and understand the phenomena involved, we need to learn about two interrelated physical concepts called thrust and pressure.

#### Activity 1

Stand on loose sand. Your feet go deep into the sand. Now, lie down on the sand. What happens? You will find that your body will not go that deep into the sand. Why?

In both the cases of the above activity, the force exerted on the sand is the weight of your body which is the same. This force acting perpendicular to the surface is called thrust. When you stand on loose sand, the force is acting on an area equal to the area of your feet. When you lie down, the same force acts on an area of your whole body, which is larger than the area of your feet. Therefore, the effect of thrust, depends on the area on which it acts.

The effect of thrust on sand is larger while standing than while lying.

The force per unit area acting on an object concerned is called pressure. Thus, we can say thrust on an unit area is pressure.

$$\text{Pressure} = \frac{\text{Thrust}}{\text{Area of contact}}$$

For the same given force, if the area is large pressure is low and vice versa. This is shown in Figure 3.1.

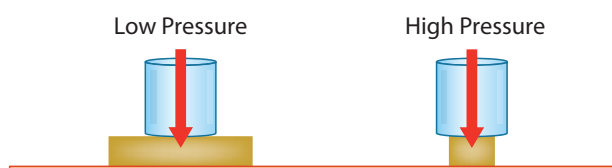

**Figure 3.1** Pressure depends on area of application

In SI units, the unit of thrust is newton (denoted as N). The unit of pressure is newton per square metre or newton metre<sup>-2</sup> (denoted as Nm<sup>-2</sup>). In the honour of the great French scientist, Blaise Pascal, 1 newton per square metre is called as 1 pascal denoted as Pa. 1 Pa = 1 N m<sup>-2</sup>



If a single nail pricks our body it is very painful. How is it possible for people to lie down on a bed of nails, still remain unhurt? It is because, area of contact is more.

### Problem 1

A man whose mass is 90 kg stands on his feet on a floor. The total area of contact of his two feet with the floor is 0.036 m<sup>2</sup> (Take, g = 10 ms<sup>-2</sup>). How much is the pressure exerted by him on the floor?

#### Solution:

The weight of the man (thrust),

$$F = mg = 90 \text{ kg} \times 10 \text{ m s}^{-2} = 900 \text{ N}$$

$$\text{Pressure, } P = \frac{F}{A} = \frac{900 \text{ N}}{0.036 \text{ m}^2} = 25000 \text{ Pa}$$

## 3.2 Pressure in Fluids

All the flowing substances, both liquids and gases are called fluids. Like solids, fluids also have weight and therefore exert pressure. When filled in a container, the pressure of the fluid is exerted in all directions and at all points of the fluid. Since the molecules of a fluid are in constant, rapid motion, particles are likely to move equally in any direction. Therefore, the pressure exerted by the fluid acts on an object from all directions. It is shown in Figure 3.2. Pressure in fluids is calculated as shown below.

$$\text{Fluid Pressure} = \frac{\text{Total force exerted by the fluid}}{\text{Area over which the force is exerted}} = \frac{F}{A}$$

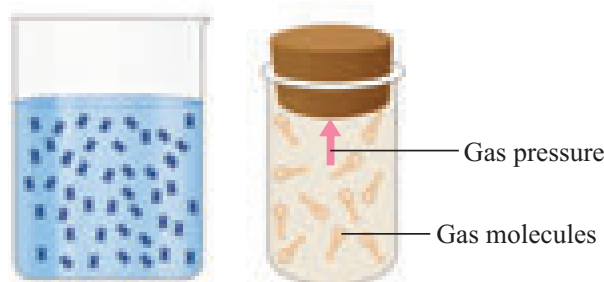

**Figure 3.2** Collision of molecules gives rise to pressure

We shall first learn about the pressure exerted by liquids and then learn about the pressure exerted by gases.

### 3.2.1 Pressure due to liquids

The force exerted due to the pressure of a liquid on a body submerged in it and on the walls of the container is always perpendicular to the surface. In Figure 3.3(a), we can see the pressure acting on all sides of the vessel.

When an air filled balloon is immersed inside the water in a vessel it immediately comes up and floats on water. This shows that water (or liquid) exerts pressure in the upward direction. It is shown in Figure 3.3(b).

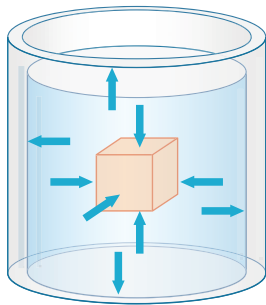

(a)



(b)



(c)

**Figure 3.3** Pressure due to fluids

Similarly, liquid pressure acts in lateral sides also. When a bottle having water is pierced on the sides we can see water coming out with a speed as in Figure 3.3(c). This is because liquid exerts lateral pressure on the walls the container.

From this activity we can infer that pressure varies as depth increases. But, it is same at a particular depth independent of the direction.

### Activity 2

Take a transparent plastic pipe. Also take a balloon and tie it tightly over one end of the plastic pipe. Pour some water in the pipe from the top. What happens? The balloon tied at the bottom stretches and bulges out. It shows that the water poured in the pipe exerts a pressure on the bottom of its container.

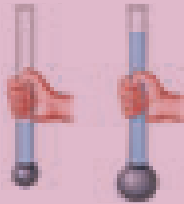

### Activity 4

Take two liquids of different densities say water and oil to a same level in two plastic containers. Make holes in the two containers at the same level. What do you see? It can be seen that water is squirting out with more pressure than oil. This indicates that pressure depends on density of the liquid.

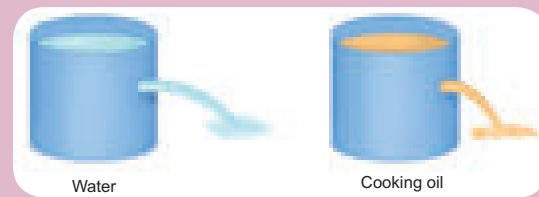

### 3.2.2 Factors determining liquid pressure in liquids

Pressure exerted by a liquid at a point is determined by,

- (i) depth ( $h$ )
- (ii) density of the liquid ( $\rho$ )
- (iii) acceleration due to gravity ( $g$ ).

### Activity 3

Take a large plastic can. Punch holes with a nail in a vertical line on the side of the can as shown in figure. Then fill the can with water. The water may just dribble out from the top hole, but with increased speed at the bottom holes as depth causes the water to squirt out with more pressure.



### 3.2.3 Pressure due to a liquid column

A tall beaker is filled with liquid so that it forms a liquid column. The area of cross section at the bottom is  $A$ . The density of the liquid is  $\rho$ . The height of the liquid column is  $h$ . In other words the depth of the water from the top level surface is 'h' as shown in Figure 3.4.

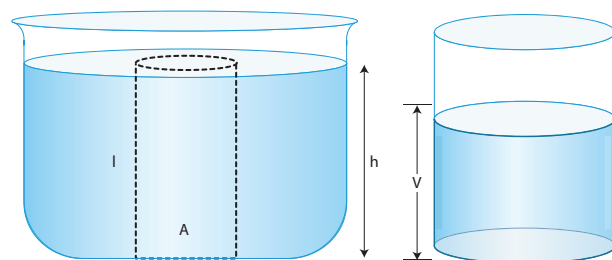

**Figure 3.4** Pressure due to a liquid column





We know that, thrust at the bottom of the column ( $F$ ) = weight of the liquid.

$$\text{Therefore, } F = mg \quad (1)$$

We can get the mass of the liquid by multiplying the volume of the liquid and its density.

$$\text{Mass, } m = \rho V \quad (2)$$

$$\begin{aligned} \text{Volume of the liquid column, } V \\ = \text{Area of cross section (A)} \times \text{Height (h)} = Ah \end{aligned} \quad (3)$$

Substituting (3) in (2)

$$\text{Mass, } m = \rho Ah \quad (4)$$

Substituting (4) in (1)

$$\text{Force} = mg = \rho Ahg$$

$$\text{Pressure, } P = \frac{\text{Thrust (F)}}{\text{Area (A)}} = \frac{mg}{A} = \frac{\rho(Ah)g}{A} = \rho hg$$

$\therefore$  Pressure due to a liquid column,  $P = h\rho g$

This expression shows that pressure in a liquid column is determined by depth, density of the liquid and the acceleration due to gravity. Interestingly, the final expression for pressure does not have the term area  $A$  in it. Thus, pressure in liquid depends on depth only.

### Problem 2

Calculate the pressure exerted by a column of water of height 0.85 m (density of water,  $\rho_w = 1000 \text{ kg m}^{-3}$ ) and kerosene of same height (density of kerosene,  $\rho_k = 800 \text{ kg m}^{-3}$ )

#### Solution:

$$\begin{aligned} \text{Pressure due to water} &= h\rho_w g \\ &= 0.85 \text{ m} \times 1000 \text{ kg m}^{-3} \times 10 \text{ m s}^{-2} = 8500 \text{ Pa.} \end{aligned}$$

$$\begin{aligned} \text{Pressure due to kerosene} &= h\rho_k g \\ &= 0.85 \text{ m} \times 800 \text{ kg m}^{-3} \times 10 \text{ m s}^{-2} = 6800 \text{ Pa.} \end{aligned}$$

## 3.3 Atmospheric pressure

Earth is surrounded by a layer of air up to certain height (nearly 300 km) and this layer of air around the earth is called atmosphere of the earth. Since air occupies space and has weight, it also exerts pressure. This pressure is called atmospheric pressure. The atmospheric pressure we normally refer is the air pressure at sea level.

Figure 3.5 shows that air gets 'thinner' with increasing altitude. Hence, the atmospheric pressure decreases as we go up in mountains. On the other hand air gets heavier as we go down below sea level like mines.

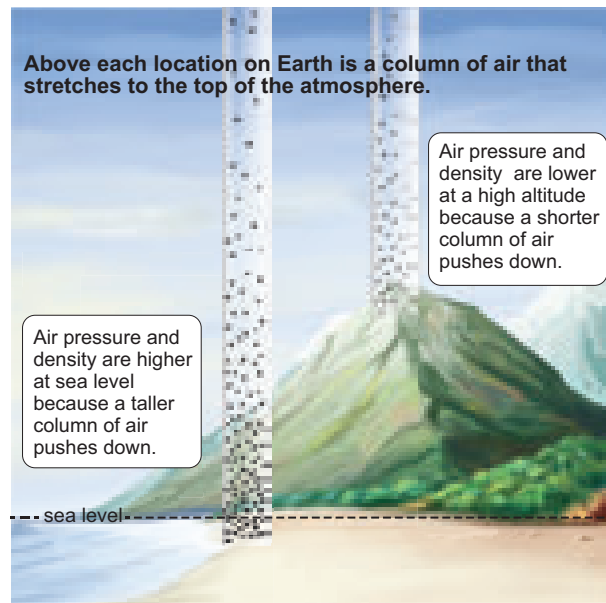

**Figure 3.5** Atmospheric pressure acts like a column



Human lung is well adapted to breathe at a pressure of sea level (101.3 k Pa). As the pressure falls at greater altitudes, mountain climbers need special breathing equipments with oxygen cylinders. Similar special equipments are used by people who work in mines where the pressure is greater than that of sea level.

### 3.3.1 Measurement of atmospheric pressure

The instrument used to measure atmospheric pressure is called barometer. A mercury barometer, first designed by an Italian Physicist Torricelli, consists of a long glass tube (closed at one end, open at the other) filled with mercury and turned upside down into a container of mercury. This is done by closing the open end of the mercury filled tube with the thumb and then opening it after immersing it in to a trough of mercury (Fig. 3.6).

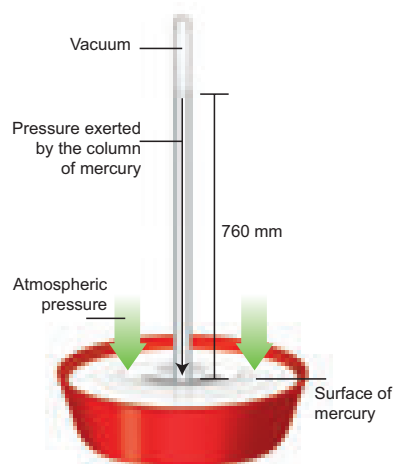

**Figure 3.6** Mercury barometer

The barometer works by balancing the mercury in the glass tube against the outside air pressure. If the air pressure increases, it pushes more of the mercury up into the tub and if the air pressure decreases, more of the mercury drains from the tube. As there is no air trapped in the space between mercury and the closed end, there is vacuum in that space. Vacuum cannot exert any pressure. So the level of mercury in the tube provides a precise measure of air pressure which is called atmospheric pressure. This type of instrument can be used in a lab or weather station.

On a typical day at sea level, the height of the mercury column is 760 mm. Let us calculate the pressure due to the mercury column of 760 mm which is equal to the atmospheric pressure. The density of mercury is  $13600 \text{ kg m}^{-3}$ .

$$\begin{aligned} \text{Pressure, } P &= h\rho g \\ &= (760 \times 10^{-3} \text{ m}) \times (13600 \text{ kg m}^{-3}) \times (9.8 \text{ m s}^{-2}) \\ &= 1.013 \times 10^5 \text{ Pa.} \end{aligned}$$

This pressure is called one atmospheric pressure (atm). There is also another unit called (bar) that is also used to express such high values of pressure.

$$1 \text{ atm} = 1.013 \times 10^5 \text{ Pa.}$$

$$1 \text{ bar} = 1 \times 10^5 \text{ Pa.}$$

$$\text{Hence, } 1 \text{ atm} = 1.013 \text{ bar.}$$

Expressing the value in kilopascal gives  $101.3 \text{ k Pa}$ . This means that, on each  $1 \text{ m}^2$  of surface, the force acting is  $1.013 \text{ k N}$ .

### Problem 3

A mercury barometer in a physics laboratory shows a 732 mm vertical column of mercury. Calculate the atmospheric pressure in pascal. [Given density of mercury,  $\rho = 1.36 \times 10^4 \text{ kg m}^{-3}$ ,  $g = 9.8 \text{ m s}^{-2}$ ]

#### Solution:

$$\begin{aligned} \text{Atmospheric pressure in the laboratory,} \\ P &= h\rho g = 732 \times 10^{-3} \times 1.36 \times 10^4 \times 9.8 \\ &= 9.76 \times 10^4 \text{ Pa (or) } 0.976 \times 10^5 \text{ Pa} \end{aligned}$$

### 3.3.2 Gauge pressure and absolute pressure

Our daily activities are happening in the atmospheric pressure. We are so used to it that we do not even realise. When tyre pressure and blood pressure are measured using instruments (gauges) they show the pressure over the atmospheric pressure. Hence, absolute pressure is zero-referenced against a perfect vacuum and gauge pressure is zero-referenced against atmospheric pressure.

For pressures higher than atmospheric pressure, absolute pressure = atmospheric pressure + gauge pressure

For pressures lower than atmospheric pressure, absolute pressure = atmospheric pressure – gauge pressure

We have seen that liquid column exerts pressure. So the pressure inside the sea will be more. This is more than twice the atmospheric pressure. Parts of our body, especially blood vessels and soft tissues cannot withstand such high pressure. Hence, scuba divers always wear special suits and equipment to protect them (Fig. 3.7).

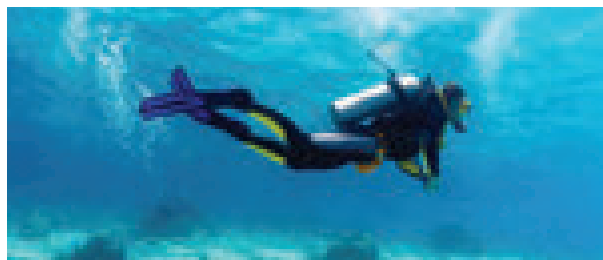

**Figure 3.7** Scuba divers with special protecting equipment





In petrol bunks, the tyre pressure of vehicles is measured in a unit called psi. It stands for pascal per inch, an old system of unit for measuring pressure.

### 3.4 Pascal's Law

Pascal's principle is named after Blaise Pascal (1623-1662), a French mathematician and physicist. The law states that the external pressure applied on an incompressible liquid is transmitted uniformly throughout the liquid. Pascal's law can be demonstrated with the help of a glass vessel having holes all over its surface. Fill it with water. Push the piston. The water rushes out of the holes in the vessel with the same pressure. The force applied on the piston exerts pressure on water. This pressure is transmitted equally throughout the liquid in all directions (Fig. 3.8). This principle is applied in various machines used in our daily life.

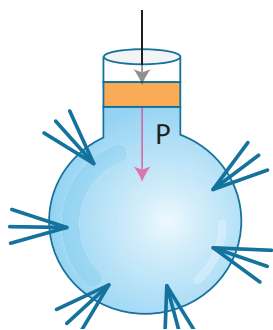

Figure 3.8 Demonstration of Pascal's Law

#### 3.4.1 Hydraulic press

Pascal's law became the basis for one of the important machines ever developed, the hydraulic press. It consists of two cylinders of different cross-sectional areas as shown in Figure 3.9. They are fitted with pistons of cross-sectional areas "a" and 'A'. The object to be lifted is placed over the piston of large cross-sectional area A. The force  $F_1$  is applied on the piston of small cross-sectional area 'a'. The pressure P produced by small piston is transmitted equally to large piston and a force  $F_2$  acts on A which is much larger than  $F_1$ .

Pressure on piston of small area 'a' is given by,

$$P = \frac{F_1}{A_1} \quad (1)$$

Applying Pascal's law, the pressure on large piston of area A will be the same as that on small piston. Therefore,  $P = \frac{F_2}{A_2}$  (2)

Comparing equations (1) and (2), we get

$$\frac{F_1}{A_1} = \frac{F_2}{A_2} \text{ or } F_2 = F_1 \times \frac{A_2}{A_1}$$

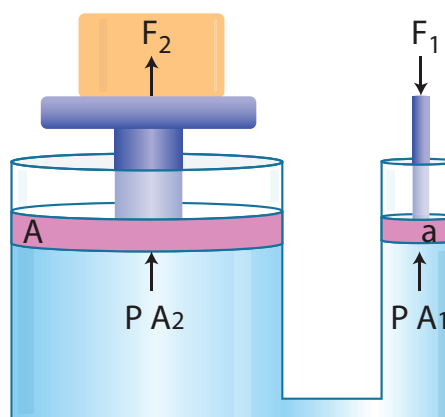

Figure 3.9 Hydraulic press

Since, the ratio  $\frac{A_2}{A_1}$  is greater than 1, the force  $F_2$  that acts on the larger piston is greater than the force  $F_1$  acting on the smaller piston. Hydraulic systems working in this way are known as *force multipliers*.

#### Problem 4

A hydraulic system is used to lift a 2000 kg vehicle in an auto garage. If the vehicle sits on a piston of area  $0.5 \text{ m}^2$ , and a force is applied to a piston of area  $0.03 \text{ m}^2$ , what is the minimum force that must be applied to lift the vehicle?

**Given:** Area covered by the vehicle on the piston  $A_1 = 0.5 \text{ m}^2$

Weight of the vehicle,  $F_1 = 2000 \text{ kg} \times 9.8 \text{ m s}^{-2}$

Area on which force  $F_2$  is applied,  $A_2 = 0.03 \text{ m}^2$

**Solution:**

$$P_1 = P_2; \frac{F_1}{A_1} = \frac{F_2}{A_2} \text{ and } F_2 = \frac{F_1}{A_1} A_2;$$

$$F_2 = (2000 \times 9.8) \frac{0.03}{0.5} = 1176 \text{ N}$$



## 3.5 Density

### Activity 5

Take two identical flasks and fill one flask with water to 250 cm<sup>3</sup> mark and the other with kerosene to the same 250 cm<sup>3</sup> mark. Measure them in a balance. The flask filled with water will be heavier than the one filled with kerosene. Why? The answer is in finding the mass per unit volume of kerosene and water in respective flasks.

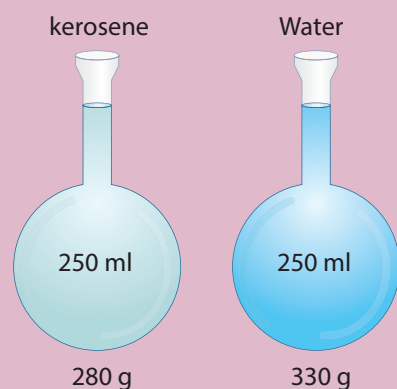

To understand density better, let us assume that the mass of the flask be 80 g. So, the mass of the flask filled with water is 330 g and the mass of flask filled with kerosene is 280 g. Mass of water only is 250 g and kerosene only is 200 g. Mass per unit volume of water is 250/250 cm<sup>3</sup>. This is 1g/cm<sup>3</sup>. Mass per unit volume of kerosene is 200 g/250 cm<sup>3</sup>. This is 0.8 g/cm<sup>3</sup>. The result 1 g/cm<sup>3</sup> and 0.8 g/cm<sup>3</sup> are the densities of water and kerosene respectively. *Therefore, the density of a substance is the mass per unit volume of a given substance.*

The SI unit of density is kilogram per meter cubic (kg/m<sup>3</sup>) also gram per centimeter cubic (g/cm<sup>3</sup>). The symbol for density is rho ( $\rho$ ).

### 3.5.1 Relative Density

We can compare the densities of two substances by finding their masses. But, generally density of a substance is compared with the density of water at 4 °C because density of water at that temperature is 1g/cm<sup>3</sup>. Density of any other substance with respect to the density of

water at 4 °C is called the relative density. Thus relative density of a substance is defined as ratio of density of the substance to density of water at 4 °C. Mathematically, relative density (R.D),

$$= \frac{\text{Density of the substance}}{\text{Density of water at 4 }^\circ\text{C}}$$

We know that, Density =  $\frac{\text{Mass}}{\text{Volume}}$

$\therefore$  Relative density

$$= \frac{\text{Mass of the substance/Volume of the substance}}{\text{Mass of water/Volume of water}}$$

Since the volume of the substance is equal to the volume of water,

Relative density

$$= \frac{\text{Mass of certain volume of substance}}{\text{Mass of equal volume of water (at 4}^\circ\text{C)}}$$

Thus, the ratio of the mass of a given volume of a substance to the mass of an equal volume of water at 4°C also denotes relative density.

### 3.5.2 Measurement of relative density

Relative density can be measured using Pycnometer also called density bottle. It consists of ground glass stopper with a fine hole through it. The function of the hole in a stopper is that, when the bottle is filled and the stopper is inserted, the excess liquid rises through the hole and runs down outside the bottle. By this way the bottle will always contain the same volume of whatever the liquid is filled in, provided the temperature remains constant. Thus, the density of a given volume of a substance to the density of equal volume of referenced substance is called relative density or specific gravity of the given substance. If the referenced substance is water then the term specific gravity is used.

### 3.5.3 Floating and sinking

Whether an object will sink or float in a liquid is determined by the density of the object compared to the density of the liquid. If the density of a substance is less than the density

of the liquid it will float. For example a piece of wood which is less dense than water will float on it. Any substance having more density than water (for example, a stone), will sink into it.

### Problem 5

You have a block of a mystery material, 12 cm long, 11 cm wide and 3.5 cm thick. Its mass is 1155 grams. (a) What is its density? (b) Will it float in a tank of water, or sink?

#### Solution:

$$\begin{aligned} \text{(a) Density} &= \frac{\text{Mass}}{\text{Volume}} = \frac{1155\text{g}}{12\text{ cm} \times 11\text{ cm} \times 3.5\text{ cm}} \\ &= \frac{1155\text{ g}}{462\text{ cm}^3} \\ &= 2.5\text{ g cm}^{-3} \end{aligned}$$

(b) The mystery material is denser than the water. So it sinks.

### 3.5.4 Application of principle of flotation

#### Hydrometer

A direct-reading instrument used for measuring the density or relative density of the liquid is called hydrometer. Hydrometer is based on the principle of flotation, i.e., the weight of the liquid displaced by the immersed portion of the hydrometer is equal to the weight of the hydrometer.

Hydrometer consists of a cylindrical stem having a spherical bulb at its lower end and a narrow tube at its upper end. The lower spherical bulb is partially filled with lead shots or mercury. This helps hydrometer to float or stand vertically in liquids. The narrow tube has markings so that relative density of a liquid can be read directly.

The liquid to be tested is poured into the glass jar. The hydrometer is gently lowered in to the liquid until it floats freely. The reading against the level of liquid touching the tube gives the relative density of the liquid.

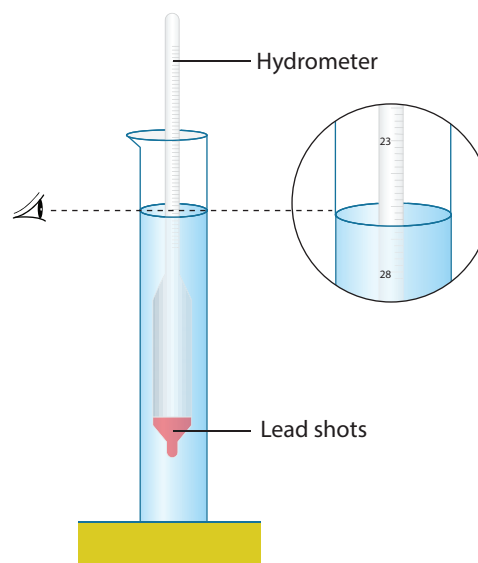

Figure 3.10 Hydrometer

Hydrometers may be calibrated for different uses such as lactometers for measuring the density (creaminess) of milk, saccharometer for measuring the density of sugar in a liquid and alcoholometer for measuring higher levels of alcohol in spirits.

#### Lactometer

One form of hydrometer is a lactometer, an instrument used to check the purity of milk. The lactometer works on the principle of gravity of milk.

The lactometer consists of a long graduated test tube with a cylindrical bulb with the graduation ranging from 15 at the top to 45 at the bottom. The test tube is filled with air. This air chamber causes the instrument to float. The spherical bulb is filled with mercury to cause the lactometer to sink up to the proper level and to float in an upright position in the milk.

Inside the lactometer there may be a thermometer extending from the bulb up into the upper part of the test tube where the scale is located. The correct lactometer reading is obtained only at the temperature of 60 °F. A lactometer measures the cream content of milk. More the cream, lower the lactometer floats in the milk. The average reading of normal milk is 32. Lactometers are used at milk processing units and dairies.

## 3.6 Buoyancy

We already saw that a body experiences an upward force due to the fluid surrounding, when it is partially or fully immersed in to it. We also know that pressure is more at the bottom and less at the top of the liquid. This pressure difference causes a force on the object and pushes it upward. This force is called buoyant force and the phenomenon is called buoyancy (Fig.3.11).

Most buoyant objects are those with a relatively high volume and low density. If the object weighs less than the amount of water it has displaced (density is less), buoyant force will be more and it will float (such object is known as positively buoyant). But, if the object weighs more than the amount of water it has displaced (density is more), buoyant force is less and the object will sink (such object is known as negatively buoyant).

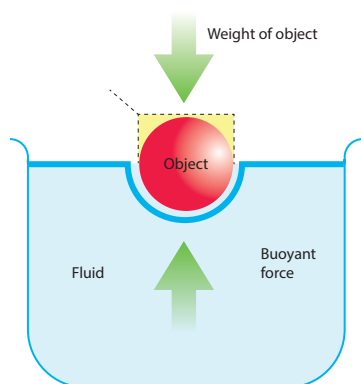

Figure 3.11 Buoyant force

**DO YOU KNOW?**

Salt water provides more buoyant force than fresh water, because, buoyant force depends as much on the density of fluids as on the volume displaced.

### 3.6.1 Cartesian diver

Cartesian diver is an experiment that demonstrates the principle of buoyancy. It is a pen cap with clay. The Cartesian diver contains just enough liquid that it barely floats in a bath of the liquid; its remaining volume is filled with air. When pressing the bath, the additional water enters the diver, thus increasing the average density of the diver, and thus it sinks.

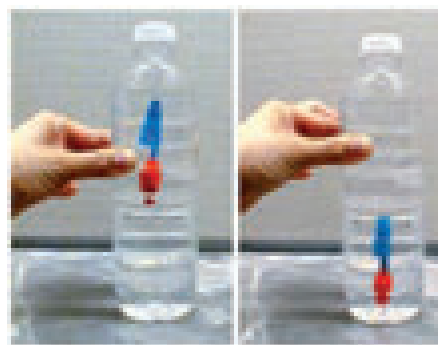

Figure 3.12 Cartesian diver

## 3.7 Archimedes' Principle

Archimedes principle is the consequence of Pascal's law. According to legend, Archimedes devised the principle of the 'hydrostatic balance' after he noticed his own apparent loss in weight while sitting in his bath. The story goes that he was so enthused with his discovery that he jumped out of his bath and ran through the town, shouting 'eureka'. Archimedes principle states that 'a body immersed in a fluid experiences a vertical upward buoyant force equal to the weight of the fluid it displaces'.

When a body is partially or completely immersed in a fluid at rest, it experiences an upthrust which is equal to the weight of the fluid displaced by it. Due to the upthrust acting on the body, it apparently loses a part of its weight and the apparent loss of weight is equal to the upthrust.

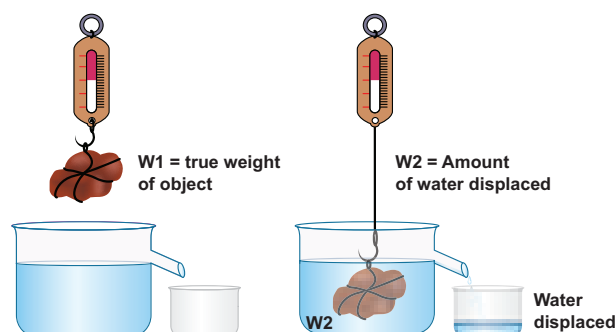

Figure 3.13 Upthrust is equal to the weight of the fluid displaced

Thus, for a body either partially or completely immersed in a fluid,

$$\begin{aligned} \text{Upthrust} &= \text{Weight of the fluid displaced} \\ &= \text{Apparent loss of weight of the body.} \end{aligned}$$

Apparent weight of an object

$$\begin{aligned} &= \text{True weight of an object in air} \\ &- \text{Upthrust (weight of water displaced)} \end{aligned}$$

### 3.8 Laws of flotation

Laws of flotation are:

1. The weight of a floating body in a fluid is equal to the weight of the fluid displaced by the body.
2. The centre of gravity of the floating body and the centre of buoyancy are in the same vertical line.

The point through which the force of buoyancy is supposed to act is known as centre of buoyancy. It is shown in Figure 3.14.

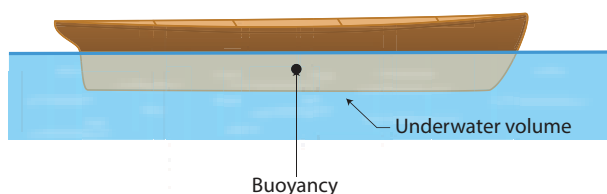

Figure 3.14 Centre of buoyancy



Flotation therapy uses water that contains Epsom salts rich in magnesium. As a floater relaxes, he or she is absorbing this magnesium through the skin. Magnesium helps the body to process insulin, which lowers a person's risk of developing Type 2 Diabetes.

#### Points to Remember

- ❖ The force which produces compression is called thrust. Its S.I. unit is newton.
- ❖ Thrust acting normally to a unit area of a surface is called pressure. Its S.I. unit is pascal.

### A-Z GLOSSARY

<b>Altitude</b>	Vertical distance in the up direction.
<b>Astronaut</b>	Person who is specially trained to travel into outer space.
<b>Axes</b>	Simple machine to cut, shape and split wood.

- ❖ The pressure exerted by the atmospheric gases on its surroundings and on the surface of the earth is called atmospheric pressure. 1 atm is the pressure exerted by a vertical column of mercury of 76 cm height.
- ❖ Barometer is an instrument used to measure atmospheric pressure.
- ❖ The upward force experienced by a body when partly or fully immersed in a fluid is called upthrust or buoyant force.
- ❖ Cartesian diver is an experiment which demonstrates the principle of buoyancy and the ideal gas law.
- ❖ Pascal's law states that an increase in pressure at any point inside a liquid at rest is transmitted equally and without any change, in all directions to every other point in the liquid.
- ❖ Archimedes' principle states that when a body is partially or wholly immersed in a fluid, it experiences an up thrust or apparent loss of weight, which is equal to the weight of the fluid displaced by the immersed part of the body.
- ❖ Density is known as mass per unit volume of a body. Its S.I. unit is  $\text{kg m}^{-3}$ .
- ❖ Relative density is the ratio between the density of a substance and density of water. Relative density of a body is a pure number and has no unit.
- ❖ Hydrometer is a device used to measure the relative density of liquids based on the Archimedes' principle.
- ❖ Lactometer is a device used to check the purity of milk by measuring its density using Archimedes' principle.



<b>Deformation</b>	Changes in an object's shape or form due to the application of a force or forces.
<b>Iceberg</b>	Large piece of ice floating in water.
<b>Hydraulic systems</b>	Device that uses fluids and work under the fluid pressure to control valves.
<b>Incompressible</b>	No change in volume if a pressure is applied.
<b>Meteorological</b>	Weather condition.
<b>Piston</b>	Movable disc fitted inside a cylinder.
<b>Propellers</b>	Fan that transmits power in the form of thrust by rotation.
<b>Syringe</b>	Simple pump made of plastic or glass to inject or withdraw fluid.
<b>Therapy</b>	Treatment given for healing sickness.
<b>Velocity</b>	Speed of an objects with direction.



## TEXTBOOK EXERCISES



### I. Choose the correct answer.

- The size of an air bubble rising up in water
  - decreases
  - increases
  - remains same
  - may increase or decrease
- Clouds float in atmosphere because of their low
  - density
  - pressure
  - velocity
  - mass
- In a pressure cooker, the food is cooked faster because
  - increased pressure lowers the boiling point.
  - increased pressure raises the boiling point.
  - decreased pressure raises the boiling point.
  - increased pressure lowers the melting point.
- An empty plastic bottle closed with an airtight stopper is pushed down into a bucket filled with water. As the bottle is pushed down, there is an increasing force on the bottom. This is because,
  - more volume of liquid is displaced.
  - more weight of liquid is displaced.
  - pressure increases with depth.
  - All the above.

### II. Fill in the blanks.

- The weight of the body immersed in a liquid appears to be \_\_\_\_\_ than its actual weight.
- The instrument used to measure atmospheric pressure is \_\_\_\_\_.
- The magnitude of buoyant force acting on an object immersed in a liquid depends on \_\_\_\_\_ of the liquid.
- A drinking straw works on the existence of \_\_\_\_\_.

### III. State whether true or false. If false, correct the statement.

- The weight of fluid displaced determines the buoyant force on an object.
- The shape of an object helps to determine whether the object will float or not.
- The foundations of high-rise buildings are kept wide so that they may exert more pressure on the ground.
- Archimedes' principle can also be applied to gases.
- Hydraulic press is used in the extraction of oil from oil seeds.





#### IV. Match the following.

Density	-	hpg
1 gwt	-	Milk
Pascal's law	-	$\frac{\text{Mass}}{\text{Volume}}$
Pressure exerted by a fluid	-	Pressure
Lactometer	-	980 dyne

#### V. Answer in brief.

1. On what factors the pressure exerted by the liquid depends on?
2. Why does a helium balloon float in air?
3. Why it is easy to swim in river water than in sea water?
4. What is meant by atmospheric pressure?
5. State Pascal's law.

#### VI. Answer in detail.

1. With an appropriate illustration prove that the force acting on a smaller area exerts a greater pressure.
2. Describe the construction and working of mercury barometer.
3. How does an object's density determine whether the object will sink or float in water?
4. Explain the construction and working of a hydrometer with diagram.
5. State the laws of flotation.

#### VII. Assertion and reason type questions.

Mark the correct answer as:

- (a) If both assertion and reason are true and reason is the correct explanation of assertion.
  - (b) If both assertion and reason are true but reason is not the correct explanation of assertion.
  - (c) If assertion is true but reason is false.
  - (d) If assertion is false but reason is true.
1. **Assertion:** To float, body must displace liquid whose weight is equal to the actual weight.

**Reason:** The body will experience no net downward force in that case.

2. **Assertion:** Pascal's law is the working principle of a hydraulic lift.

**Reason:** Pressure is thrust per unit area.

#### VIII. Numerical Problems.

1. A block of wood of weight 200 g floats on the surface of water. If the volume of block is  $300 \text{ cm}^3$ , calculate the upthrust due to water.
2. Density of mercury is  $13600 \text{ kg m}^{-3}$ . Calculate the relative density.
3. The density of water is  $1 \text{ g cm}^{-3}$ . What is its density in S.I. units?
4. Calculate the apparent weight of wood floating on water if it weighs 100g in air.

#### IX. Higher Order Thinking Skills.

1. How high does the mercury barometer stand on a day when atmospheric pressure is 98.6 kPa?
2. How does a fish manage to rise up and move down in water?
3. If you put one ice cube in a glass of water and another in a glass of alcohol, what would you observe? Explain your observations.
4. Why does a boat with a hole in the bottom would eventually sink?



#### REFERENCE BOOKS

1. Fundamentals of Physics - By David Halliday and Robert Resnick.
2. I.C.S.E Concise Physics - By Selina publisher.
3. Physics - By Tower, Smith Tuston & Cope.



#### INTERNET RESOURCES

- [https://www.teachengineering.org/lessons/view/cub\\_airplanes\\_lesson04](https://www.teachengineering.org/lessons/view/cub_airplanes_lesson04)
- [http://www.cyberphysics.co.uk/topics/earth/atmosphr/atmospheric\\_pressure.htm](http://www.cyberphysics.co.uk/topics/earth/atmosphr/atmospheric_pressure.htm)
- <http://discovermagazine.com/2003/mar/featscienceof>
- <http://northwestfloatcenter.com/how-flotation-can-help-your-heart/>



# Concept Map

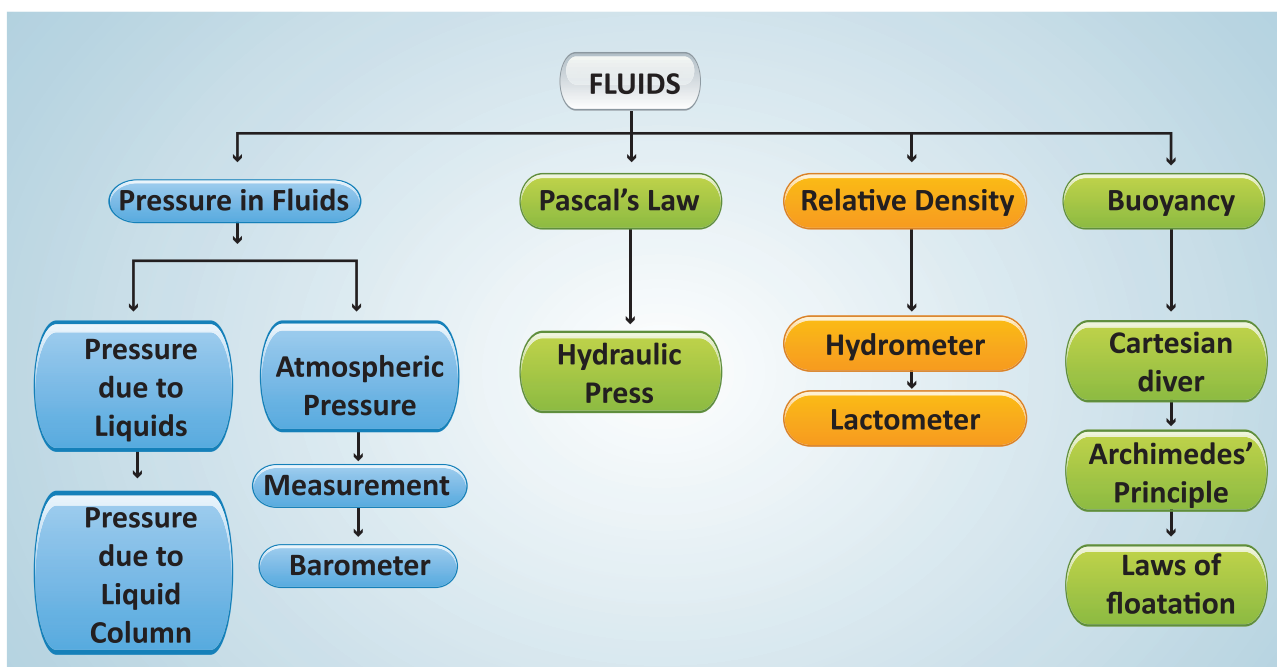

## ICT CORNER

## Fluid

Experiment with Fluid Pressure and Flow using virtual simulator.

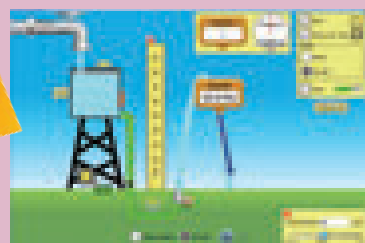

### Steps

- Type the given URL to reach “phet simulation” page and download the “java” file of “Fluid Pressure and Flow”.
- Open the “java” file. Open the water tap and observe the “Pressure” fluctuations by increasing “Fluid density” and “Gravity”.
- Select the third picture and drop down a weight scales to transform weight into pressure.
- Switch to “Flow” tab from the top to simulate fluid motion under a given shape and pressure. Click the “red” button to drop dots into the fluid and alter the pipe shape by dragging the yellow holders.



Step1

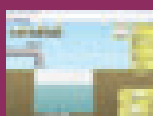

Step2

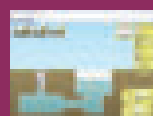

Step3



Step4

### Fluid Pressure and Flow Simulator

URL: <https://phet.colorado.edu/en/simulation/fluid-pressure-and-flow> or Scan the QR Code.

\*Pictures are indicative only



B567\_9\_SCI\_EM\_T3

## UNIT

# 4

# ELECTRIC CHARGE AND ELECTRIC CURRENT

## Learning Objectives



After completing this lesson, students will be able to:

- understand the electric charge, electric field and Coulomb's law.
- explain the concepts of electric current, voltage, resistance and Ohm's law.
- draw electrical circuit diagrams for series and parallel circuits.
- explain the effects of electric current like. heating or thermal effect, chemical effect, and magnetic effect.
- understand direct and alternating currents.
- know the safety aspects related to electricity.

## Introduction

Like mass and length, electric charge also is a fundamental property of all matter. We know that matter is made up of atoms and molecules. Atoms have particles like electrons, protons and neutrons. By nature, electrons and protons have negative and positive charge respectively and neutrons do not have charge. An electric current consists of moving electric charges. Electricity is an important source of energy in the modern times. In this lesson, we will study about electric charges, electric current, electric circuit diagram and the effects of electric current.

### 4.1 Electric charges

Inside each atom there is a nucleus with positively charged protons and chargeless neutrons and negatively charged electrons orbiting the nucleus. Usually there are as many electrons as there are protons and the atoms themselves are neutral.

If an electron is removed from the atom, the atom becomes positively charged. Then it is called a positive ion. If an electron is added in excess to an atom then the atom is negatively charged and it is called negative ion.

When you rub a plastic comb on your dry hair, the comb obtains power to attract small pieces of paper, is it not? When you rub the comb vigorously, electrons from your hair leave and accumulate on the edge of the comb. Your hair is now positively charged as it has lost electrons and the comb is negatively charged as it has gained electrons.

#### 4.1.1 Measuring electric charge

Electric charge is measured in coulomb and the symbol for the same is C. The charge of an electron is numerically a very tiny value. The charge of an electron (represented as  $e$ ) is the fundamental unit with a charge equal to  $1.6 \times 10^{-19}$  C. This indicates that any charge ( $q$ ) has to be an integral multiple ( $n$ ) of this fundamental unit of electron charge ( $e$ ).  
 $q = ne$ . Here,  $n$  is a whole number.



### Problem 1

How many electrons will be there in one coulomb of charge?

#### Solution:

Charge on 1 electron,  $e = 1.6 \times 10^{-19} \text{ C}$

$$q = ne \text{ or } n = q/e$$

$\therefore$  number of electrons in 1 coulomb

$$= \frac{1}{1.6 \times 10^{-19}} = 6.25 \times 10^{18} \text{ electrons}$$

Practically, we have  $\mu\text{C}$  (micro coulomb),  $\text{nC}$  (nano coulomb) and  $\text{pC}$  (pico coulomb) as units of electric charge.

$$1 \mu\text{C} = 10^{-6} \text{ C}, 1 \text{nC} = 10^{-9} \text{ and } 1 \text{pC} = 10^{-12} \text{ C}$$

Electric charge is additive in nature. The total electric charge of a system is the algebraic sum of all the charges located in the system. For example, let us say that a system has two charges  $+5\text{C}$  and  $-2\text{C}$ . Then the total or net charge on the system is,  $(+5\text{C}) + (-2\text{C}) = +3\text{C}$ .



Electrostatic forces between two point charges obey Newton's third law. The force on one charge is the action and on the other is reaction and vice versa.

### 4.1.2 Electric force

Among electric charges, there are two types of electric force (F): one is attractive and the other is repulsive. The like charges repel and unlike charges attract. **The force existing between the charges is called as 'electric force.'** These forces can be experienced even when the charges are not in contact.

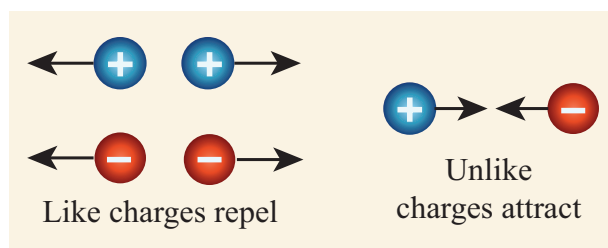

Figure 4.1 Electrostatic forces

### 4.1.3 Electric field

The region in which a charge experiences electric force forms the 'electric field' around the charge. Often electric field (E) is represented by lines and arrowheads indicating the direction of the electric field (Fig. 4.2). The direction of the electric field is the direction of the force that would act on a small positive charge. Therefore the lines representing the electric field are called 'electric lines of force.' **The electric lines of force are straight or curved paths along which a unit positive charge tends to move in the electric field.** Electric lines of force are imaginary lines. The strength of an electric field is represented by how close the field lines are to one another.

For an isolated positive charge the electric lines of force are radially outwards and for an isolated negative charge they are radially inwards.

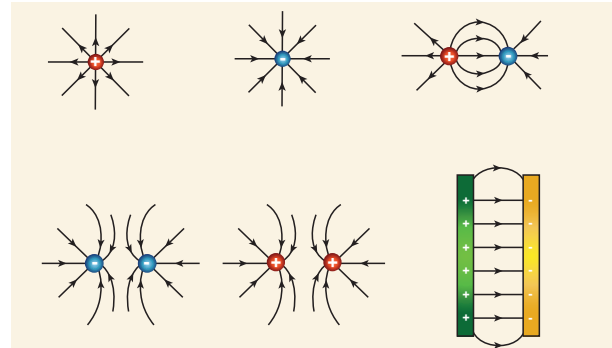

Figure 4.2 Electric lines of force

Electric field at a point is a measure of force acting on a unit positive charge placed at that point. A positive charge will experience force in the direction of electric field and a negative charge will experience in the opposite direction of electric field.

### 4.1.4 Electric potential

Though there is an electric force (either attractive or repulsive) existing among the charges, they are still kept together, is it not?. We now know that in the region of electric charge there is an electric field. Other charges experience force in this field and vice versa. There is a work done on the charges to keep them together. This results in a quantity called 'electric potential.'

**Electric potential is a measure of the work done on unit positive charge to bring it to that point against all electrical forces.**

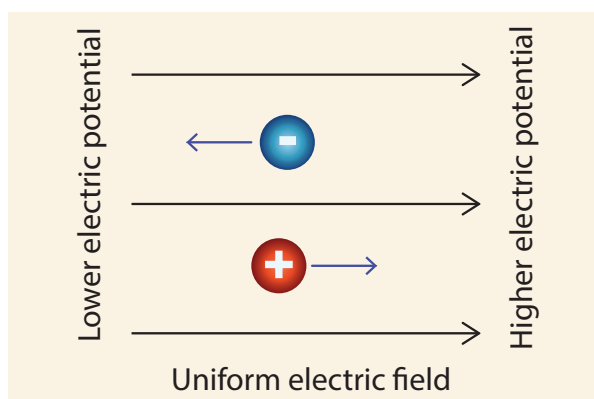

**Figure 4.3** Electric potential and Electric field

## 4.2 Electric current

When the charged object is provided with a conducting path, electrons start to flow through the path from higher potential to lower potential region. Normally, the potential difference is produced by a cell or battery. When the electrons move, we say that an electric current is produced. That is, an electric current is formed by moving electrons.

### 4.2.1 Direction of current

Before the discovery of the electrons, scientists believed that an electric current consisted of moving positive charges. Although we know this is wrong, the idea is still widely held, as the discovery of the flow of electrons

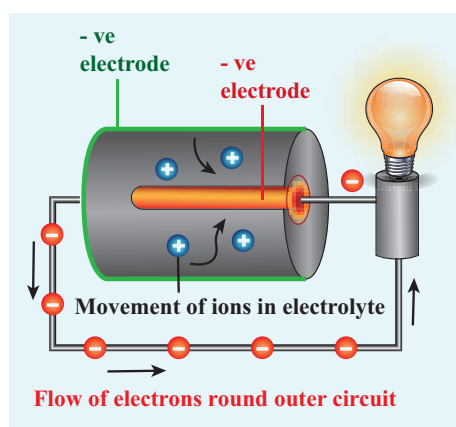

**Figure 4.4** Electric current

did not affect the basic understanding of the electric current. The movement of the positive charge is called as 'conventional current'. The flow of electrons is termed as 'electron current'. This is depicted in Figure 4.4.

In electrical circuits the positive terminal is represented by a long line and negative terminal as a short line. Battery is the combination of more than one cell (Fig. 4.5).

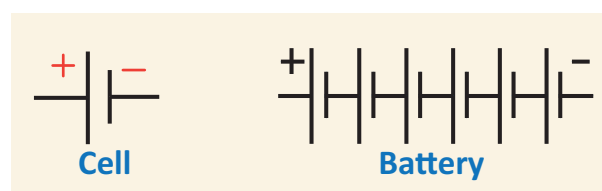

**Figure 4.5** Cell and battery

### 4.2.2 Measurement of electric current

We can measure the value of current and express it numerically. **Current is the rate at which charges flow past a point on a circuit.** That is, if  $q$  is the quantity of charge passing through a cross section of a wire in time  $t$ , quantity of current ( $I$ ) is represented as,

$$I = q/t$$

The standard SI unit for current is ampere with the symbol A. Current of 1 ampere means that there is one coulomb (1C) of charge passing through a cross section of a wire every one second (1 s).

$$1 \text{ ampere} = 1 \text{ coulomb} / 1 \text{ second (or)} \\ 1 \text{ A} = 1 \text{ C} / 1 \text{ s} = 1\text{Cs}^{-1}$$

**Ammeter is an instrument used to measure the strength of the electric current in an electric circuit.**

The ammeter is connected in series in a circuit where the current is to be found. . The current flows through the positive (+) red terminal of ammeter and leaves from the negative (-) black terminal.

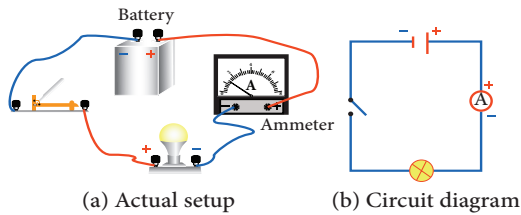

**Figure 4.6** Ammeter in a circuit

### Problem 2

If, 25 C of charge is determined to pass through a wire of any cross section in 50 s, what is the measure of current?

#### Solution:

$$I = q / t = (25 \text{ C}) / (50 \text{ s}) = 0.5 \text{ C/s} = 0.5 \text{ A}$$

### Problem 3

The current flowing through a lamp is 0.2A. If the lamp is switched on for one hour, what is the total electric charge that passes through the lamp?

#### Solution:

$$I = q / t; q = I \times t$$

$$1 \text{ hr} = 1 \times 60 \times 60 \text{ s} = 3600 \text{ s}$$

$$q = I \times t = 0.2 \text{ A} \times 3600 \text{ s} = 720 \text{ C}$$

### 4.2.3 Electromotive force (e.m.f)

Imagine that two ends of a water pipe filled with water are connected. Although filled with water, the water will not move or circle around the tube on its own. Suppose, you insert a pump in between and the pump pushes the water, then the water will start moving in the tube. Now the moving water can be used to produce some work. We can insert a water wheel in between the flow and make it to rotate and further use that rotation to operate machinery.



Likewise if you take a circular copper wire, it is full of free electrons. However, they are not moving in a particular direction. You need some force to push the electrons to move in a direction. The water pump and a battery are compared in Figure 4.7.

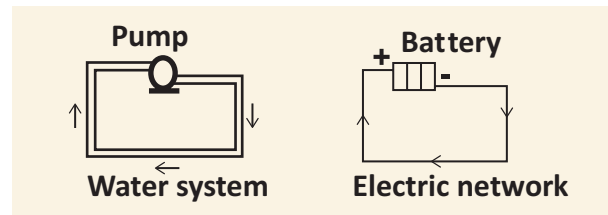

**Figure 4.7** Battery is analogous to water pump

Devices like electric cells and other electrical energy sources act like pump, 'pushing' the charges to flow through a wire or conductor. The 'pumping' action of the electrical energy source is made possible by the 'electromotive force' (e.m.f). The electromotive force is represented as ( $\epsilon$ ). The e.m.f of an electrical energy source is the work done ( $W$ ) by the source in driving a unit charge ( $q$ ) around the complete circuit.

$\epsilon = W/q$  where,  $W$  is the work done. The SI unit of e.m.f is joules per coulomb ( $\text{JC}^{-1}$ ) or volt (V). In other words **the e.m.f of an electrical energy source is one volt if one joule of work is done by the source to drive one coulomb of charge completely around the circuit.**

### Problem 4

The e.m.f of a cell is 1.5 V. What is the energy provided by the cell to drive 0.5 C of charge around the circuit?

#### Solution:

$$\epsilon = 1.5 \text{ V and } q = 0.5 \text{ C}$$

$$\epsilon = W/q; W = \epsilon \times q;$$

$$\text{Therefore } W = 1.5 \times 0.5 = 0.75 \text{ J}$$

### 4.2.4 Potential difference (pd)

One does not just let the circuit connect one terminal of a cell to another. Often we connect, say a bulb or a small fan or any other electrical device in an electric circuit and use the electric current to drive them. This is how a certain amount of electrical energy provided by the cell or any other

source of electrical energy is converted into other form of energy like light, heat, mechanical and so on. For each coulomb of charge passing through the light bulb (or any appliances) the amount of electrical energy converted to other forms of energy depends on the potential difference across the electrical device or any electrical component in the circuit. The potential difference is represented by the symbol  $V$ .

$$V = W/q$$

where,  $W$  is the work done, i.e., the amount of electrical energy converted into other forms of energy measured in joule and  $q$  is amount of charge measured in coulomb. The SI unit for both e.m.f and potential difference is the same i.e., volt (V).

#### Problem 5

A charge of  $2 \times 10^4$  C flows through an electric heater. The amount of electrical energy converted into thermal energy is  $5 \times 10^6$  J. Compute the potential difference across the ends of the heater.

#### Solution:

$$V = W/q \text{ that is } 5 \times 10^6 \text{ J} / 2 \times 10^4 \text{ C} = 250 \text{ V}$$

Voltmeter is an instrument used to measure the potential difference. To measure the potential difference across a component in a circuit, the voltmeter must be connected in parallel to it. Say, you want to measure the potential difference across a light bulb, you need to connect the voltmeter as given in Figure 4.8.

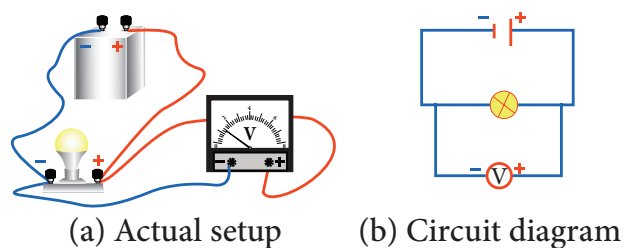

Figure 4.8 Connection of voltmeter in a circuit

Note the positive (+) red terminal of the voltmeter is connected to the positive side of circuit and the negative (–) black terminal is connected to the negative side of the circuit across a component (light bulb in the above illustration).

### 4.2.5 Resistance

The Resistance ( $R$ ) is the measure of opposition offered by the component to the flow of electric current through it. Different electrical components offer different electrical resistance.

Metals like copper, aluminium etc., have very much negligible resistance. That is why they are called good conductors. On the other hand, materials like nicrome, tin oxide etc., offer high resistance to the electric current. We also have a category of materials called insulators; they do not conduct electric current at all (glass, polymer, rubber and paper). All these materials are needed in electrical circuits to have usefulness and safety in electrical circuits.

The SI unit of resistance is ohm with the symbol ( $\Omega$ ). **One ohm is the resistance of a component when the potential difference of one volt applied across the component drives a current of one ampere through it.**

We can also control the amount of flow of current in a circuit with the help of resistance. Such components used for providing resistance are called as ‘resistors’. The resistors can be fixed or variable.

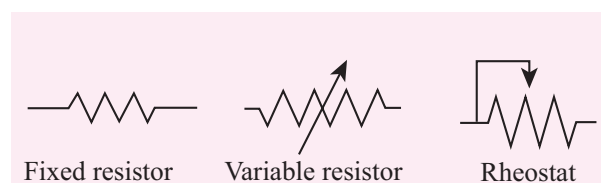

Figure 4.9 Circuit symbol for resistor

Fixed resistors have fixed value of resistance, while the variable resistors like rheostats can be used to obtain desired value of resistance (Fig. 4.9).

**Note:** Difference between e.m.f and potential difference:

As both e.m.f and potential difference are measured in volt, they may appear the same. But they are not. The e.m.f refers to the voltage developed across the terminals of an electrical source when it does not produce current in the circuit. Potential difference refers to the voltage developed between any two points (even across electrical devices) in an electric circuit when there is current in the circuit.

### 4.3 Electric circuit diagram

To represent an electrical wiring or solve problem involving electric circuits, the circuit diagrams are made.

The four main components of any circuits namely, (i) cell, (ii) connecting wire, (iii) switch and (iv) resistor or load are given above. In addition to the above many other electrical components are also used in an actual

circuit. A uniform system of symbols has been evolved to describe them. It is like learning a sign language, but useful in understanding circuit diagrams. Some common symbols in the electrical circuit are shown in Table 4.1.

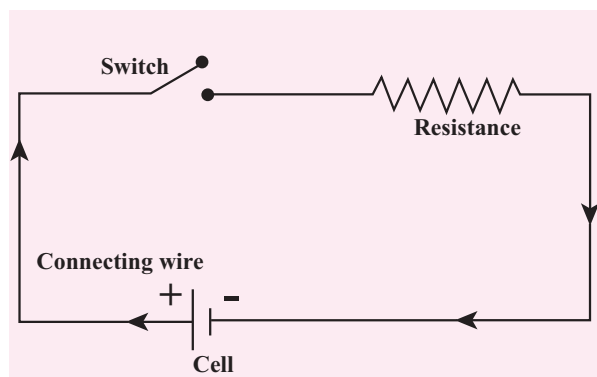

Figure 4.10 Typical electric circuit

#### Activity 1

Take a condemned electronic circuit board in a TV remote or old mobile phone. Look at the electrical symbols used in the circuit. Find out the meaning of the symbols known to you.

Table 4.1 Common symbols in electrical circuits

Symbol	Device	Symbol	Device	Symbol	Device
	Switch		Wires joined		galvanometer
	Cell		Wires crossed		ammeter
	Battery		Fixed resistor		Voltmeter
	D .c . power supply		variable resistor (rheostat)		Two-way switch
	A.c. power supply		fuse		Earth connector
	Light bulb		Coil of wire		capacitor
	Potentiometer		transformer		thermistor
	light-dependent resistor (LDR)		Semiconductor diode		bell



### 4.3.1 Different electrical circuits

Look at the two circuits, shown in Figure 4.11. In Figure A two bulbs are connected in series and in Figure B they are connected in parallel. Let us look at each of these separately.

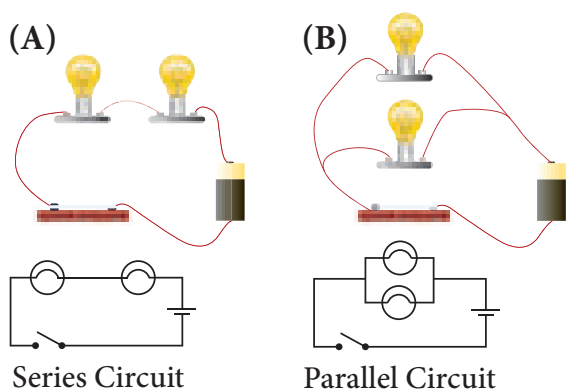

Figure 4.11 Series and parallel connections

#### Series circuits

Let us first look at the current in a series circuit. In a series circuit the components are connected one after another in a single loop. In a series circuit there is only one pathway through which the electric charge flows. From the above we can know that the current  $I$  all along the series circuit remains the same. That is, in a series circuit the current in each point of the circuit is the same.

#### Parallel circuits

In parallel circuits, the components are connected to the e.m.f. source in two or more loops. In a parallel circuit there is more than one path for the electric charge to flow. In a parallel circuit the sum of the individual currents in each of the parallel branches is equal to the main current flowing into or out of the parallel branches. Also, in a parallel circuit the potential difference across separate parallel branches is the same.

## 4.4 Effects of electric current

When current flows in a circuit it exhibits various effects. The main effects are heating, chemical and magnetic effects.

### 4.4.1 Heating effect

#### Activity 2

Cut an arrow shaped strip from aluminium foil. Ensure that the head is a fine point. Keep the arrow shaped foil on a wooden

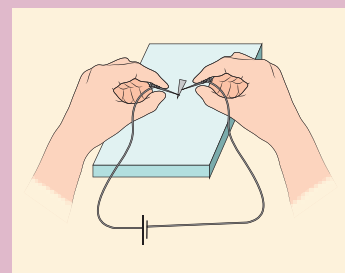

board. Connect a thin pin to two lengths of wire. Connect the wires to the terminals of an electric cell, maybe of 9V. Press one pin onto the pointed tip and the other pin at a point about one or two mm away. Can you see that the tip of the aluminium foil starts melting?

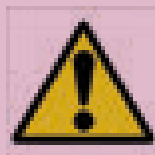

**Caution:** The heating effect and the chemical effect experiments have to be performed only with a dc cell of around 9V. Students at any cost **should not use** the main domestic electric supply which is a 220V ac voltage. If it is used it will give a heavy electric shock leading to a severe damage to our body.

When the flow of current is 'resisted' generally heat is produced. This is because the electrons while moving in the wire or resistor suffer resistance. Work has to be done to overcome the resistance which is converted into heat energy. **This conversion of electrical energy into heating energy is called 'Joule heating'** as this effect was extensively studied by the scientist Joule. This forms the principle of all electric heating appliances like iron box, water heater, toaster etc. Even connecting wires offer a small resistance to the flow of current. That is why almost all electrical appliances including the connecting wires are warm when used in an electric circuit.

## 4.4.2 Chemical effect

### Activity 3

Take a beaker half filled with copper sulphate solution. Take a carbon rod from a used dry cell. Wind a wire on its upper end. Take a thick copper wire, clean it well and flatten it with a hammer. Immerse both the copper wire and carbon rod in the copper sulphate solution. Connect the carbon rod to the negative terminal of an electric cell and copper wire to the positive terminal of the cell. Also ensure that the copper and the carbon rod do not touch each other, but are close enough. Wait and watch. After some time you would find fine copper deposited over the carbon rod. This is called as electroplating. This is due to the chemical effect of current.

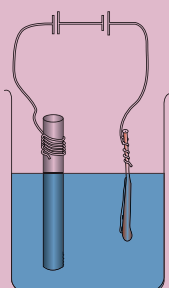

So far we have come across the cases in which only the electrons can conduct electricity. But, here when current passes through electrolyte like copper sulphate solution, both the electron and the positive copper ion conduct electricity. **The process of conduction of electric current through solutions is called 'electrolysis'. The solution through which the electricity passes is called 'electrolyte'.** The positive terminal inserted in to the solution is called 'anode' and the negative terminal 'cathode'. In the above experiment, copper wire is anode and carbon rod is cathode.



Extremely weak electric current is produced in the human body by the movement of charged particles. These are called synaptic signals. These signals are produced by electro-chemical process. They travel between brain and the organs through nervous system.

## 4.4.3 Magnetic effect of electricity

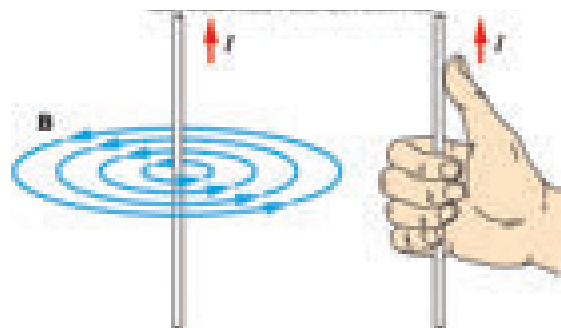

Figure 4.12 Direction of current and magnetic field

**A wire or a conductor carrying current develops a magnetic field perpendicular to the direction of the flow of current. This is called magnetic effect of current.** The discovery of the scientist Oersted and the 'right hand thumb rule' are detailed in the chapter on Magnetism and Electromagnetism in this book.

Direction of current is shown by the right hand thumb and the direction of magnetic field is shown by other fingers of the same right hand (Fig. 4.12).

## 4.5 Types of current

There are two distinct types of electric currents that we encounter in our everyday life: direct current (dc) and alternating current (ac).

### 4.5.1 Direct current

We know current in electrical circuits is due to the motion of positive charge from higher potential to lower potential or electron from lower to higher electrical potential. Electrons move from negative terminal of the battery to positive of the battery. Battery is used to maintain a potential difference between the two ends of the wire. Battery is one of the sources for dc current. The dc is due to the unidirectional flow of electric charges. Some other sources of dc are solar cells, thermocouples etc. The graph depicting the direct current is shown in Figure 4.13.

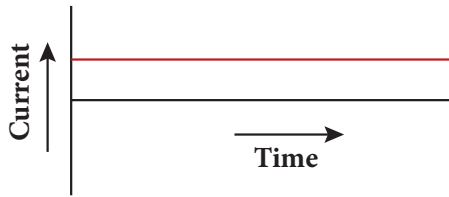
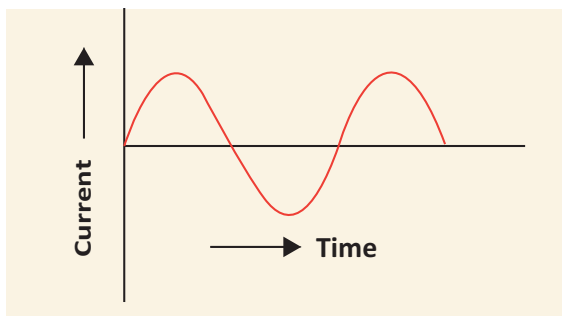

**Figure 4.13** Wave form of dc

Many electronic circuits use dc. Some examples of devices which work on dc are cell phones, radio, electric keyboard, electric vehicles etc.

### 4.5.2 Alternating current

If the direction of the current in a resistor or in any other element changes its direction alternately, the current is called an alternating current. The alternating current varies sinusoidally with time. This variation is characterised by a term called as frequency. **Frequency is the number of complete cycle of variation, gone through by the ac in one second.** In ac, the electrons do not flow in one direction because the potential of the terminals vary between high and low alternately. Thus, the electrons move to and fro in the wire carrying alternating current. It is diagrammatically represented in Figure 4.14.



**Figure 4.14** Wave form of ac

Domestic supply is in the form of ac. When we want to use an electrical device in dc, then we have to use a device to convert ac to dc. **The device used to convert ac to dc is called rectifier.** Colloquially it is called with several names like battery eliminator, dc adaptor and so on. The device used to convert dc into ac is called inverter. The symbols used in ac and dc circuits are shown in Figure 4.15.

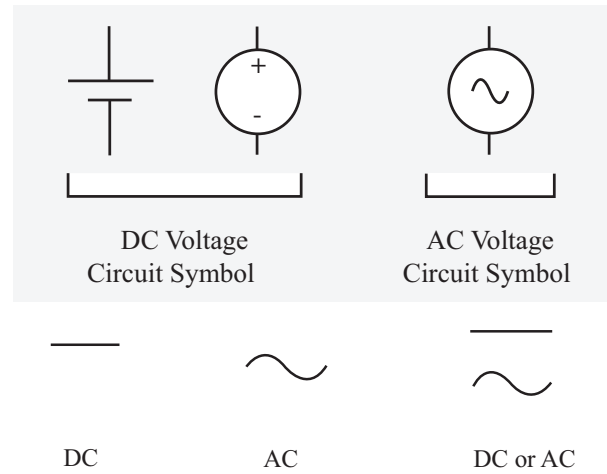

**Figure 4.15** The symbol used in ac and dc circuit diagrams

### 4.5.3 Advantages of ac over dc

The voltage of ac can be varied easily using a device called transformer. The ac can be carried over long distances using step up transformers. The loss of energy while distributing current in the form of ac is negligible. Direct current cannot be transmitted as such. The ac can be easily converted into dc and generating ac is easier than dc. The ac can produce electromagnetic induction which is useful in several ways.

### 4.5.4 Advantage of dc

Electroplating, electro refining and electrotyping can be done only using dc. Electricity can be stored only in the form of dc.



In India, the voltage and frequency of ac used for domestic purpose is 220 V and 50 Hz respectively where as in United States of America it is 110 V and 60 Hz respectively.

## 4.6 Dangers of electricity and precautions to be taken

The following are the possible dangers as for as electric current is concerned.

**Damaged insulation:** Do not touch the bare wire. Use safety gloves and stand on insulating stool or rubber slippers while handling electricity.

**Overload of power sockets:** Do not connect too many electrical devices to a single electrical socket.

**Inappropriate use of electrical appliances:** Always use the electrical appliances according to the power rating of the device like ac point, TV point, microwave oven point etc.

**Environment with moisture and dampness:** Keep the place, where there is electricity, out of moisture and wetness as it will lead to leakage of electric current.

**Beyond the reach of children:** The electrical sockets are to be kept away from the reach of little children who do not know the dangers of electricity.



Resistance of a dry human body is about 1,00,000 ohm. Because of the presence of water in our body the resistance is reduced to few hundred ohm. Thus, a normal human body is a good conductor of electricity. Hence, precautions are required while doing electrical work.

### Points to Remember

- ❖ Electric charge is a fundamental property of all matter.
- ❖ Like charges repel and unlike charges attract.
- ❖ Electric field (E) is represented by lines and arrowheads indicating the direction of the electric field.
- ❖ Electric current flows from higher electric potential to lower electric potential.
- ❖ The movement of the positive charge is called as 'conventional current'. The flow of electrons is termed as 'electron current'.
- ❖ The opposition to the flow of current is called resistance.
- ❖ The SI unit of resistance is ohm with the symbol  $\Omega$ .
- ❖ The four main components of any circuit are: cell, connecting wire, switch and resistor.
- ❖ In a parallel circuit there is more than one path for the electric charge to flow.
- ❖ The main effects when current flows in a circuit are heating, chemical and magnetic effects.
- ❖ There are two distinct types of electric currents that we encounter in our everyday life: direct current (dc) and alternating current (ac).

## A-Z GLOSSARY

<b>Electric charge</b>	It is the fundamental property of matter.
<b>Electric field</b>	The region around a charge in which another charge experiences electric force.
<b>Electric lines of force</b>	The electric lines of force are straight or curved paths along which a unit positive charge tends to move in the electric field.
<b>Electric potential</b>	Measure of the work done on unit positive charge to bring it to that point against all electrical forces.
<b>Electric current</b>	Electric current is the rate at which charges flow across a conductor in a circuit.
<b>Ammeter</b>	An instrument used for measuring the amount of electric current.
<b>e.m.f</b>	Work done by the electrical energy source in driving a unit charge around the complete circuit.



<b>Voltmeter</b>	An instrument used to measure the potential difference.
<b>Resistance</b>	The measure of opposition offered by the component to the flow of electric current through it.
<b>Resistors</b>	Components used for providing resistance.
<b>Electrolyte</b>	The solution through which electric current flows.
<b>Anode</b>	The positive terminal in the electrolyte.
<b>Cathode</b>	The negative terminal in the electrolyte.
<b>Alternating current</b>	Current in a resistor or in any other element which changes its direction alternately.



## TEXTBOOK EXERCISES



### I. Choose the correct answer.

- In current electricity, a positive charge refers to,
  - presence of electron
  - presence of proton
  - absence of electron
  - absence of proton
- Rubbing of comb with hair
  - creates electric charge
  - transfers electric charge
  - either (a) or (b)
  - neither (a) nor (b)
- Electric field lines \_\_\_\_\_ from positive charge and \_\_\_\_\_ in negative charge.
  - start; start
  - start; end
  - start: end
  - end; end
- Potential near a charge is the measure of its \_\_\_\_\_ to bring a positive charge at that point.
  - force
  - ability
  - tendency
  - work
- Heating effect of current is called,
  - Joule heating
  - Coulomb heating
  - Voltage heating
  - Ampere heating
- In an electrolyte the current is due to the flow of
  - electrons
  - positive ions
  - both (a) and (b)
  - neither (a) nor (b)
- Electroplating is an example for
  - heating effect
  - chemical effect
  - flowing effect
  - magnetic effect
- Resistance of a wire depends on,
  - temperature
  - geometry
  - nature of material
  - all the above

### II. Match the following.

- Electric charge (a) ohm
- Potential difference (b) ampere
- Electric field (c) coulomb
- Resistance (d) newton per coulomb
- Electric current (e) volt

### III. State whether true or false. If false, correct the statement.

1. Electrically neutral means it is either zero or equal positive and negative charges.
2. Ammeter is connected in parallel in any electric circuit.
3. The anode in electrolyte is negative.
4. Current can produce magnetic field.

### IV. Fill in the blanks.

1. Electrons move from \_\_\_\_\_ potential to \_\_\_\_\_ potential.
2. The direction opposite to the movement of electron is called \_\_\_\_\_ current.
3. The e.m.f of a cell is analogous to \_\_\_\_\_ of a pipe line.
4. The domestic electricity in India is an ac with a frequency of \_\_\_\_\_ Hz.

### V. Conceptual questions.

1. A bird sitting on a high power electric line is still safe. How?
2. Does a solar cell always maintain the potential across its terminals constant? Discuss.
3. Can electroplating be possible with alternating current?

### VI. Answer the following.

1. On what factors does the electrostatic force between two charges depend?
2. What are electric lines of force?
3. Define electric field.
4. Define electric current and give its unit.
5. State Ohm's law.
6. Name any two appliances which work under the principle of heating effect of current.

7. How are the home appliances connected in general, in series or parallel. Give reasons.
8. List the safety features while handling electricity.

### VII. Exercises.

1. Rubbing a comb on hair makes the comb get  $-0.4C$ . (a) Find which material has lost electron and which one gained it. (b) Find how many electrons are transferred in this process.
2. Calculate the amount of charge that would flow in 2 hours through an element of an electric bulb drawing a current of 2.5 A.
3. The values of current (I) flowing through a resistor for various potential differences V across the resistor are given below. What is the value of resistor?

I (ampere)	0.5	1.0	2.0	3.0	4.0
V (volt)	1.6	3.4	6.7	10.2	13.2

[Hint: plot V-I a graph and take slope]



### REFERENCE BOOKS

Fundamentals of Physics - K.L Gomer and K. L.Gogia  
Concepts of Physics - H.C Verma  
General Physics - W.L. Whiteley



### INTERNET RESOURCES

<http://www.qrg.northwestern.edu/projects/vss/docs/propulsion/1-what-is-an-ion.html>  
<https://www.explainthatstuff.com/batteries.html>  
<https://www.woodies.ie/tips-n-advice/how-the-fusebox-works-in-the-home-new>

## Concept Map

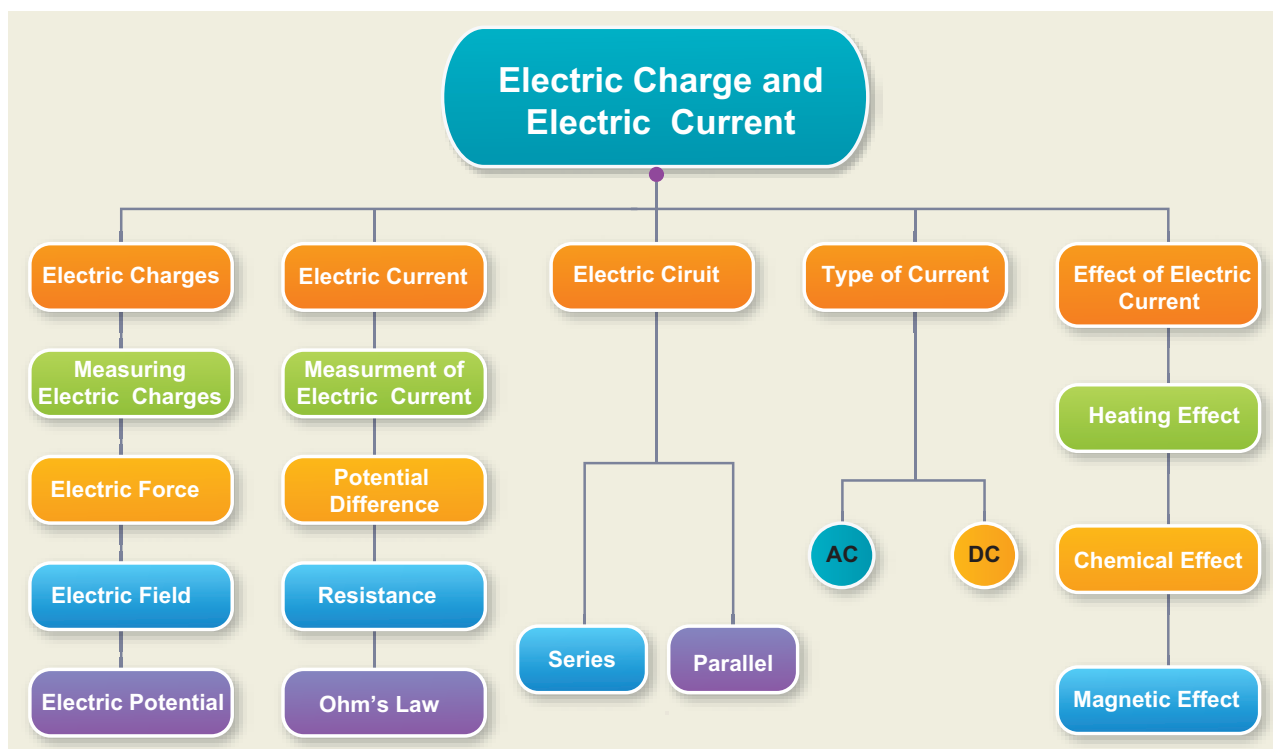

ICT CORNER

## Ohm's Law Verification

This activity enables to learn the relationship between current and potential difference.

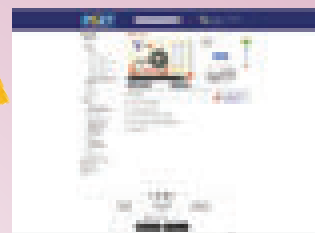

### Step 1

- Type the URL link given below in the browser OR scan the QR code.
- You can vary the value of V and R to know the change the **current flowing across the conductor**
- On the right you can do the changes in V and R to learn the variations.



Step1

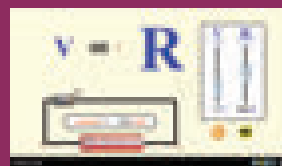

Step2

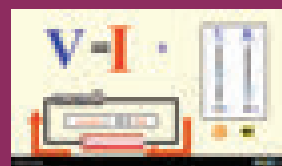

Step3

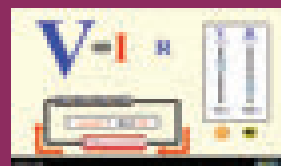

Step4

### Browse in the link:

URL: <https://phet.colorado.edu/en/simulation/ohms-law>



B567\_9\_SCI\_EM\_T3

\*Pictures are indicative only

# MAGNETISM AND ELECTROMAGNETISM

## Learning Objectives

After completing this lesson, students will be able to

- understand the concept of magnetic field.
- know the properties of magnetic field lines.
- calculate the force exerted on a current carrying conductor in a magnetic field.
- understand the force between two parallel current carrying conductors.
- know the concept of electromagnetic induction and apply it in the case of generators.
- appreciate how voltage can be increased or decreased using transformers.
- understand the applications of electromagnet and apply the knowledge in constructing devices using electromagnets.



## Introduction

Have you ever played with magnets? Do you wonder why it attracts iron? Magnets are always attractive objects for the humans. In fact famous scientist Einstein has mentioned that he was always attracted by magnets in his childhood. In the olden days magnets were used in the ships. Captains of the ships effectively used the magnets to identify the direction of the ship in the sea.

There are two kinds of magnets that we can see around us: Natural magnet and Artificial magnet. Natural magnets exist in the nature. These kind of magnets can be found in rocks and sandy deposits in various parts of the world. The strongest natural magnet is lodestone magnetite.

The magnetic property in the natural magnets is permanent. It never gets destroyed. The lodestones were used to make compasses in the olden days. Artificial magnets are made

by us. The magnets available in the shops are basically artificial magnets. In this lesson we shall study about properties of magnets, magnetic effect of current, electromagnetic induction and applications of electromagnets.

## 5.1 Magnetic field (B)

### Activity 1

Put a magnet on a table and place some paper clips nearby. If you push the magnet slowly towards the paper clips, there will be a point at which the paper clips jump across and stick to the magnet. What do you understand from this?

From the above activity we notice that magnets have an invisible field all around them which attracts magnetic materials. In this space we can feel the force of attraction or repulsion due to the magnet. Thus, magnetic



field is the region around the magnet where its magnetic influence can be felt. It is denoted by  $B$  and its unit is Tesla.

The direction of the magnetic field around a magnet can be found by placing a small compass in the magnetic field (Fig 5.1).

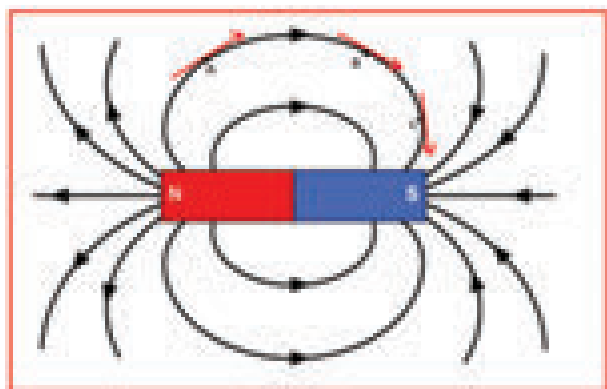

**Figure 5.1** Compass showing direction of magnetic field

Magnetic field can penetrate through all kinds of materials, not just air. The Earth produces its own magnetic field, which shields the earth's ozone layer from the solar wind and it is important for navigation also.

## 5.2 Magnetic Field Lines

A magnetic field line is defined as a curve drawn in the magnetic field in such a way that the tangent to the curve at any point gives the direction of the magnetic field. They start at north pole and ends at south pole. In Figure 5.2, the arrow mark indicates the direction of magnetic field at points A, B and C. Note carefully that the magnetic field at a point is tangential to the magnetic field lines.



**Figure 5.2** Magnetic field lines

### 5.2.1 Magnetic flux

Magnetic flux is the number of magnetic field lines passing through a given area (Fig. 5.3). It is denoted by  $\phi$  and its unit is weber (Wb).

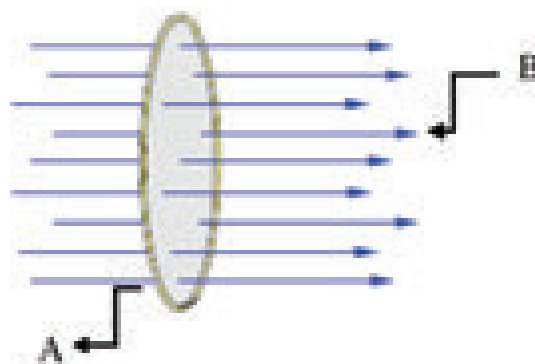

**Figure 5.3** Magnetic flux

The number of magnetic field lines crossing unit area kept normal to the direction of field lines is called magnetic flux density. It is shown in Figure 5.4. Its unit is  $\text{Wb/m}^2$

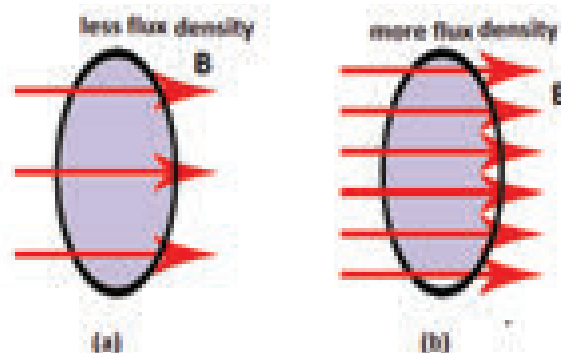

**Figure 5.4** Magnetic flux density



Some sea turtles (loggerhead sea turtle) return to their birth beach many decades after they were born, to nest and lay eggs. In a research, it is suggested that the turtles can perceive variations in magnetic parameters of Earth such as magnetic field intensity and remember them. This memory is what helps them in returning to their homeland.



## 5.2.2 Properties of magnetic lines of force

- Magnetic lines of force are closed, continuous curves, extending through the body of the magnet.
- Magnetic lines of force start from the North Pole and end at the South Pole.
- Magnetic lines of force never intersect.
- They will be maximum at the poles than at the equator.
- The tangent drawn at any point on the curved line gives the direction of magnetic field.

## 5.3 Magnetic effect of current

It was on 21st April 1820, Hans Christian Oersted, a Danish Physicist was giving a lecture. He was demonstrating electrical circuits in that class. He had to often switch on and off the circuit during the lecture. Accidentally, he noticed the needle of the magnetic compass that was on the table. It deflected whenever he switched on and the current was flowing through the wire. The compass needle moved only slightly, so that the audience didn't even notice. But, it was clear to Oersted that something significant was happening. He conducted many experiments to find out a startling effect, the magnetic effect of current.

Oersted aligned a wire XY such that they were exactly along the North-South direction. He kept one magnetic compass above the wire at A and another under the wire at B. When the circuit was open and no current was flowing through it, the needle of both the compass was pointing to north. Once the circuit was closed and electric current was flowing, the needle at A pointed to east and the needle at B to the west as shown in Figure 5.5. This showed that current carrying conductor produces magnetic field around it.

The direction of the magnetic lines around a current carrying conductor can be easily understood using the right hand thumb rule. Hold the wire with four fingers of your right hand with thumbs-up position. If the direction of the current is towards the thumb then the magnetic lines curl in the same direction as your other four fingers as shown in Figure 5.6. This shows that the magnetic field is always perpendicular to the direction of current.

The strength of the magnetic field at a point due to current carrying wire depends on: (i) the current in the wire, (ii) distance of the point from the wire, (iii) the orientation of the point from the wire and (iv) the magnetic nature of the medium. The magnetic field lines are stronger near the current carrying wire and it diminishes as you go away from it. This is represented by drawing magnetic field lines closer together near the wire and farther away from the wire.

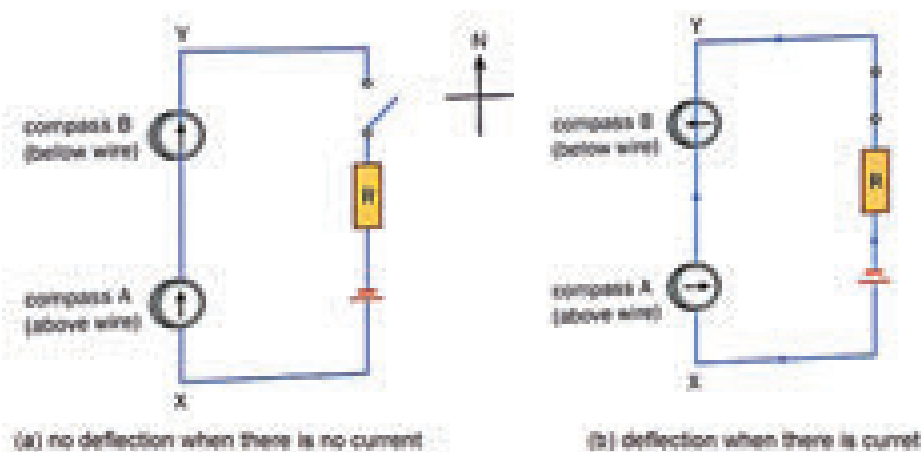
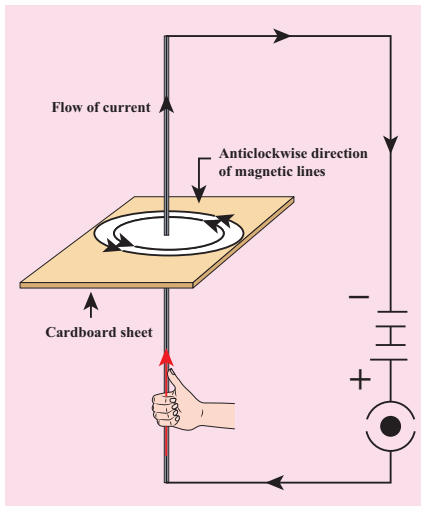

Figure 5.5 Current produces magnetic field



**Figure 5.6** Right hand thumb rule

## 5.4 Force on a current carrying conductor in a magnetic field

H.A.Lorentz found that a charge moving in a magnetic field, in a direction other than the direction of magnetic field, experiences a force. It is called the magnetic Lorentz force. Since charge in motion constitutes a current, a conductor carrying moving charges, placed in magnetic field other than the direction of magnetic field, will also experience a force and can produce motion in the conductor.

### Activity 2

Take a cardboard and thread a wire perpendicular through it. Connect the wire such that current flows up the wire. Switch on the circuit. Let the current flow. Place a magnetic compass on the cardboard and mark the position. Now move magnet and mark the new position. If you join all the points you will find that it is a circle. Reverse the direction of the current, you will find the magnetic circles are clockwise.

From this activity, we infer that current carrying wire has a magnetic field perpendicular to the wire (by looking at the deflection of the compass needle in the vicinity of a current carrying conductor). The deflection of the needle implies that the current carrying conductor exerts a force on the compass needle. In 1821, Michael Faraday discovered that a current carrying conductor also gets deflected when it is placed in a magnetic field. In Figure 5.7, we can see that the magnetic field of the permanent magnet and the magnetic field produced by the current carrying conductor interact and produce a force on the conductor. The view perpendicular to the direction of current is shown in Figure 5.8.

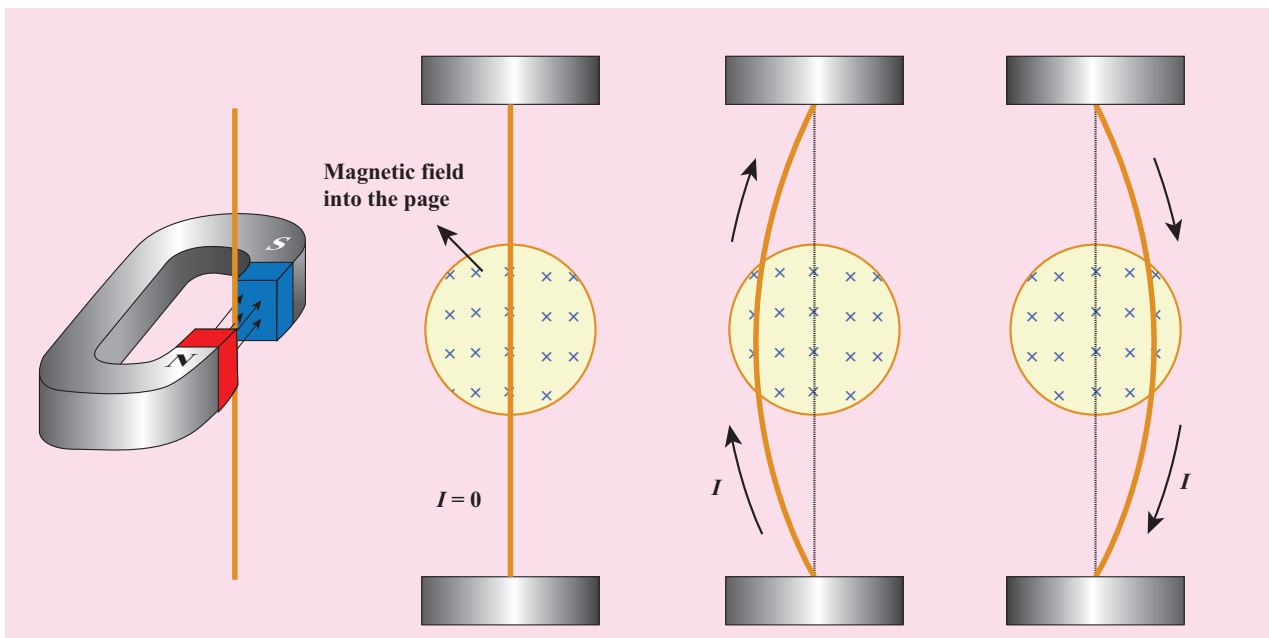

**Figure 5.7** Deflection of current carrying wire in magnetic field



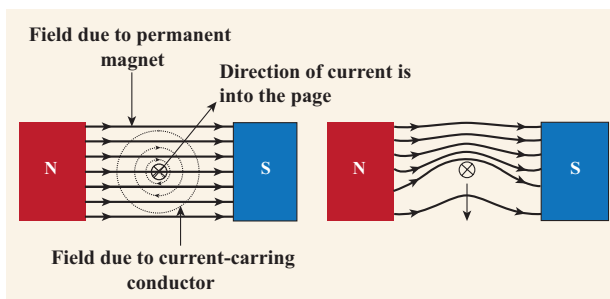

**Figure 5.8** Force on a current carrying conductor kept in magnetic field

If a current,  $I$  is flowing through a conductor of length,  $L$  kept perpendicular to the magnetic field  $B$ , then the force  $F$  experienced by it is given by the equation,

$$F = I L B$$

The above equation indicates that the force is proportional to current through the conductor, length of the conductor and the magnetic field in which the current carrying conductor is kept.

**Note:** The angle of inclination between the current and magnetic field also affects the magnetic force. When the conductor is perpendicular to the magnetic field, the force will be maximum ( $=BIL$ ). When it is parallel to the magnetic field, the force will be zero.

The force is always a vector quantity. A vector quantity has both magnitude and direction. It means we should know the direction in which the force would act. The direction is often found using what is known as Fleming's Left hand Rule (formulated by the scientist John Ambrose Fleming).

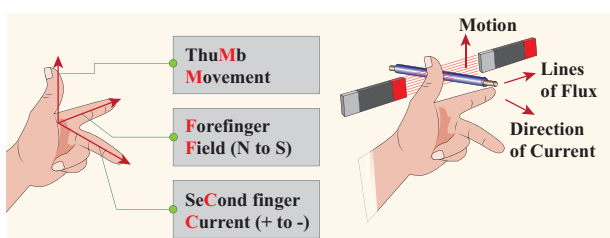

**Figure 5.9** Fleming's left hand rule

The law states that while stretching the three fingers of left hand in perpendicular

manner with each other, if the direction of the current is denoted by the middle finger of the left hand and the second finger is for direction of the magnetic field, then the thumb of the left hand denotes the direction of the force or movement of the conductor (Fig. 5.9)

### Problem 1

A conductor of length 50 cm carrying a current of 5 A is placed perpendicular to a magnetic field of induction  $2 \times 10^{-3}$  T. Find the force on the conductor.

#### Solution:

Force on the conductor =  $ILB$

$$= 5 \times 50 \times 10^{-2} \times 2 \times 10^{-3}$$

$$= 5 \times 10^{-3} \text{ N}$$

### Problem 2

A current carrying conductor of certain length, kept perpendicular to the magnetic field experiences a force  $F$ . What will be the force if the current is increased four times, length is halved and magnetic field is tripled?

#### Solution:

$$F = I L B = (4I) \times (L/2) \times (3 B) = 6 F$$

Therefore, the force increases six times.

## 5.5 Force on parallel current carrying conductors

We have seen that a current carrying conductor has a magnetic field around it. If we place another conductor carrying current parallel to the first one, the second conductor will experience a force due to the magnetic field of the first conductor. Similarly, the first conductor will experience a force due to the magnetic field of the second conductor. These two forces will be equal in magnitude and opposite in direction.

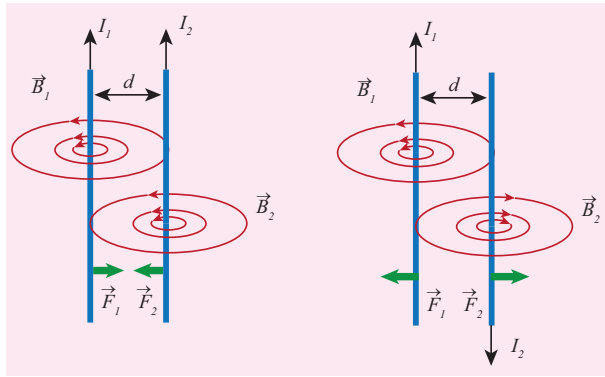

**Figure 5.10** Attractive and repulsive force on current carrying wires

Using Fleming's left hand rule we can find that the direction of the force on each wire would be towards each other when the current in both of them are flowing in the same direction, i.e., the wires would experience an attractive force. However, if the direction of the flow of current is in opposite direction, then the force on each of the wire will be in opposite direction. These are shown in Figure 5.10 and the perpendicular view of the same is shown in Figure 5.11.

### Connection between Electricity and Magnetism:

Before 18th century people thought that magnetism and electricity were separate subjects of study. After Oersted's experiment the electricity and magnetism were united and became a single subject called 'Electromagnetism'.

When there is current, the magnetic field is produced and the current carrying conductor behaves like a magnet. You may now wonder how was it possible for a lodestone to behave like a magnet when there was no current passing through it. Only in the twentieth century, we understood that the magnetic property arises due to the motion of electrons in the lodestone. In the circuit the electrons flow from negative of the battery to positive of the battery and constitutes current. As a result it produces magnetic field. In natural magnets and artificial magnets that we buy in shops, the electrons move around the nucleus constitutes

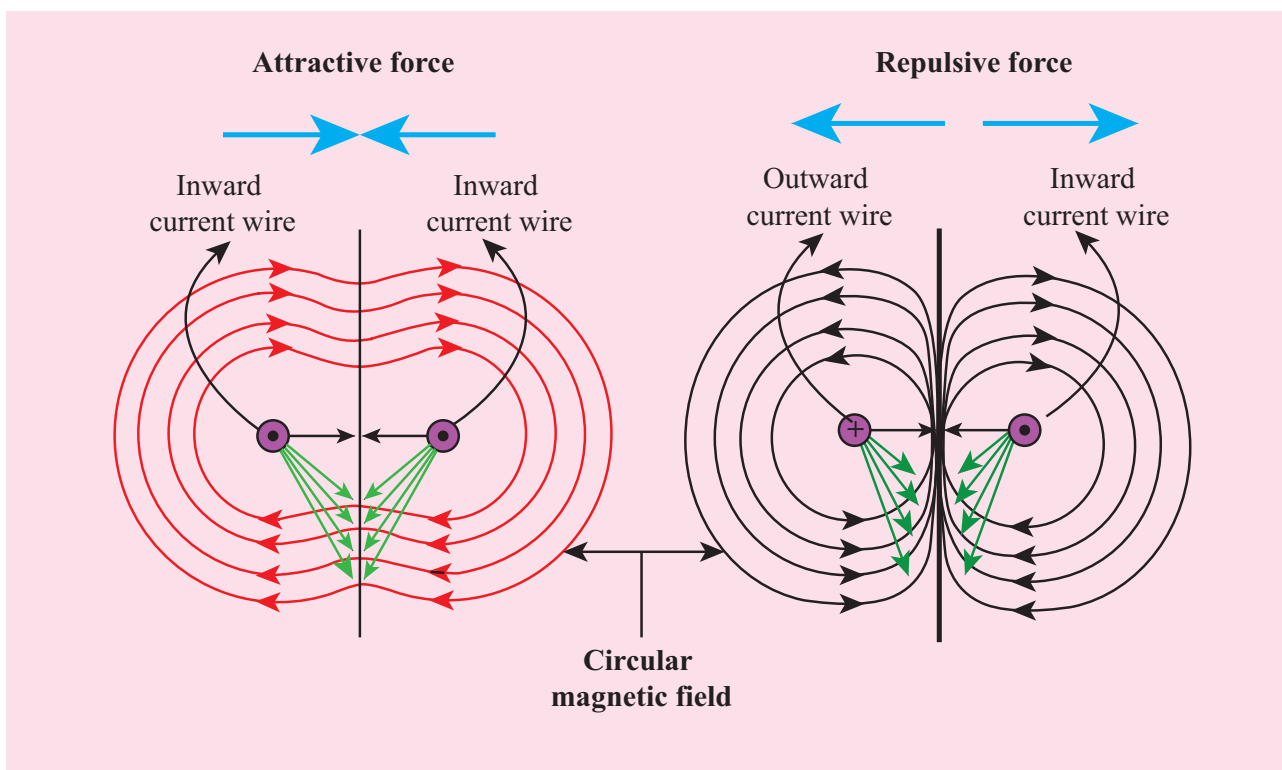

**Figure 5.11** Force on current carrying conductors when viewed perpendicular to the direction of current

current which leads to magnetic property. Here, every orbiting electron in its orbit is like a current carrying loop. Even though in all the materials electrons orbit around the nucleus, only for certain special type of material called magnetic material the motion of electrons around the nucleus gets added up and as a result we have permanent magnetic field.

## 5.6 Electric motor

An electric motor is a device which converts electrical energy into mechanical energy. Electric motors are crucial in modern life. They are used in water pump, fan, washing machine, juicer, mixer, grinder etc. We have already seen that when electric current is passed through a conductor placed normally in a magnetic field, a force is acting on the conductor and this force makes the conductor to move. This is harnessed to construct an electric motor.

To understand how a motor works, we need to understand how a current carrying coil experiences a turning effect when placed inside a permanent magnetic field.

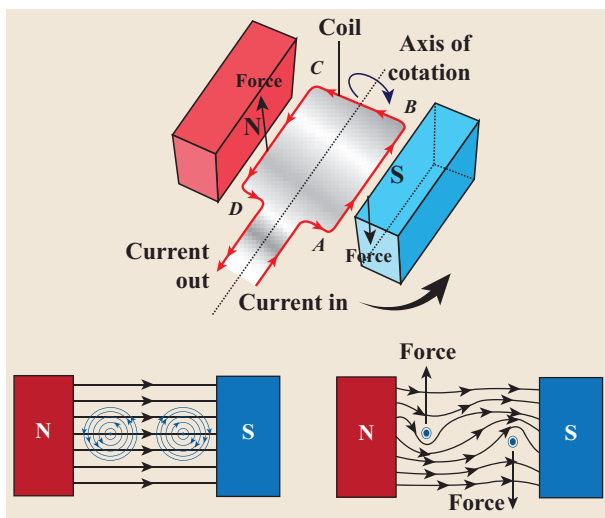

Figure 5.12 Turning effect in a coil

In Figure. 5.12, a simple coil is placed inside two poles of a magnet. Now look at the current carrying conductor segment AB. The direction of the current is towards B, whereas in the conductor segment CD the direction is opposite. As the current is flowing in opposite directions in the segments AB and CD, the direction of the motion of the segments would be in opposite directions according to Fleming's left hand rule. When two ends of the coil experience force in opposite direction, they rotate.

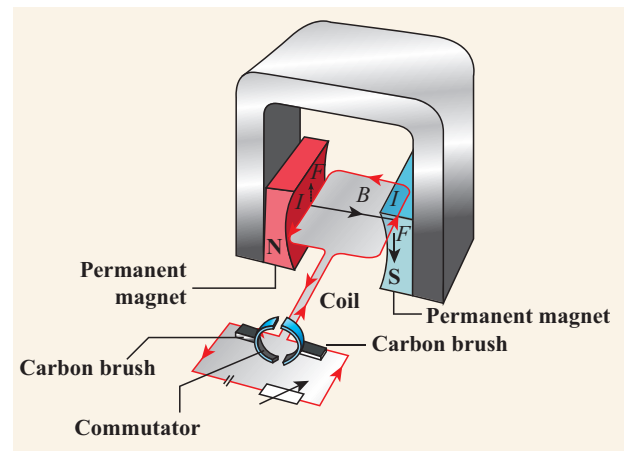

Figure 5.13 Principle of electric motor

If the current flow is along the line ABCD, then the coil will rotate in clockwise direction first and then in anticlockwise direction. If we want to make the coil rotate in any one direction, say clockwise, then the direction of the current should be along ABCD in the first half of the rotation and along DCBA in the second half of the rotation. To change the direction of the current, a small device called split ring commutator is used.

When the gap in the split ring commutator is aligned with terminals X and Y, there is no flow of current in the coil. But, as the coil is moving, it continues to move forward bringing one of the split ring commutator in contact with the carbon brushes X and Y. The reversing of the current is repeated at each half rotation, giving rise to a continuous rotation of the coil.

The speed of rotation of coil can be increased by:

- i. increasing the strength of current in the coil.
- ii. increasing the number of turns in the coil.
- iii. increasing the area of the coil and
- iv. increasing the strength of the magnetic field.

## 5.7 Electromagnetic Induction

When it was shown by Oersted that magnetic field is produced around a conductor carrying current, the reverse effect was also attempted. In 1831, Michael Faraday explained the possibility of producing an e.m.f across the conductor when the magnetic flux linked with the conductor is changed. In order to demonstrate this, Faraday conducted few experiments.

### 5.7.1 Faraday's experiments

#### Experiment 1

In this experiment, two coils were wound on a soft iron ring (separated from each other). The coil on the left is connected to a battery and a switch K. A galvanometer is attached to the coil on the right. When the switch is put 'on', at that instant, there is a deflection in the galvanometer. Likewise, when the switch is put 'off', again there is a deflection – but in the opposite direction. This proves the generation of current.

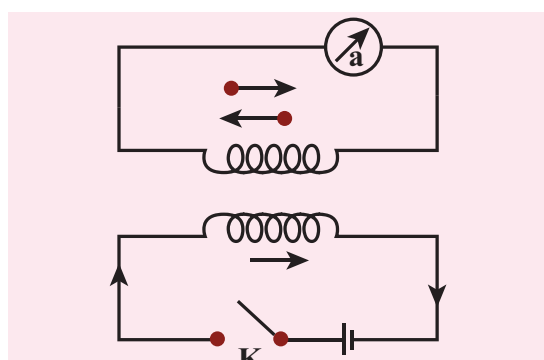
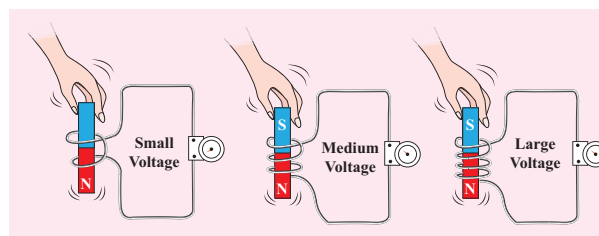

**Figure 5.14** Electromagnetic induction in a current carrying coil

#### Experiment 2

In this experiment, current (or voltage) is generated by the movement of the magnet

in and out of the coil. The greater the number of turns, the higher is the voltage generated.



**Figure 5.15** Electromagnetic induction by moving the magnet

#### Experiment 3

In this experiment, the magnet is stationary, but the coil is moved in and out of the magnetic field (indicated by the magnetic lines of force). Here also, current is induced.

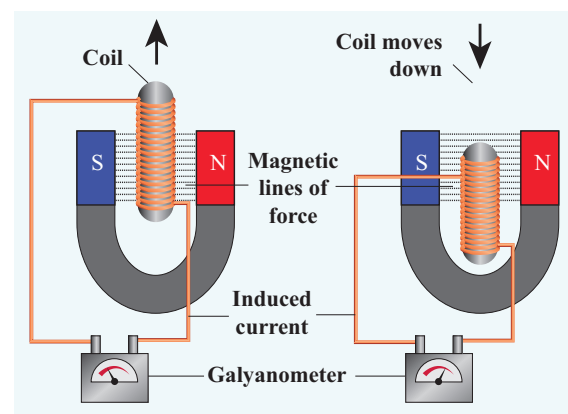

**Figure 5.16** Electromagnetic induction by moving the coil

All these observations made Faraday to conclude that whenever there is a change in the magnetic flux linked with a closed circuit an emf is produced and the amount of emf induced varies directly as the rate at which the flux changes. This emf is known as induced emf and the phenomenon of producing an induced emf due to change in the magnetic flux linked with a closed circuit is known as electromagnetic induction.

**Note:** The direction of the induced current was given by Lenz's law, which states that the induced current in the coil flows in such a direction as to oppose the change that causes it. The direction of induced current can also be given by another rule called Fleming's Right Hand Rule.

### Activity 3

#### Create your own electromagnet

You are given a long iron nail, insulation coated copper wire and a battery. Can you make your own electromagnet?

### Know Your Scientist

Michael Faraday (22<sup>nd</sup> Sep, 1791–25<sup>th</sup> Aug, 1867) was a British Scientist who contributed to the study of electromagnetism and electrochemistry. His main discoveries include the principles underlying electromagnetic induction, diamagnetism and electrolysis.

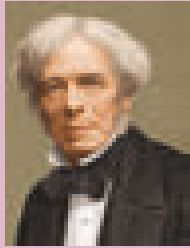

### 5.7.2 Fleming's Right Hand Rule

Stretch the thumb, fore finger and middle finger of your right hand mutually perpendicular to each other. If the fore finger indicates the direction of magnetic field and the thumb indicates the direction of motion of the conductor, then the middle finger will indicate the direction of induced current. Fleming's Right hand rule is also called 'generator rule'.

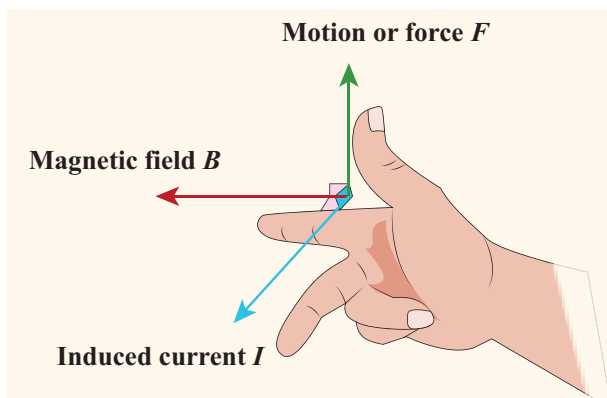

Figure 5.17 Fleming's right hand rule

## 5.8 Electric generator

An alternating current (AC) generator, as shown in Figure 5.18, consists of a rotating rectangular coil ABCD called armature placed between the two



poles of a permanent magnet. The two ends of this coil are connected to two slip rings  $S_1$  and  $S_2$ . The inner sides of these rings are insulated. Two conducting stationary brushes  $B_1$  and  $B_2$  are kept separately on the rings  $S_1$  and  $S_2$  respectively. The two rings  $S_1$  and  $S_2$  are internally attached to an axle. The axle may be mechanically rotated from outside to rotate the coil inside the magnetic field. Outer ends of the two brushes are connected to the external circuit.

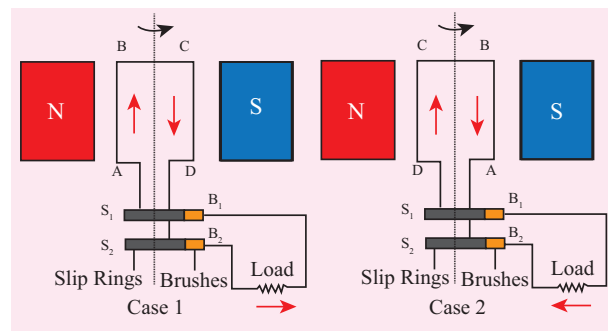

Figure 5.18 AC generator

When the coil is rotated, the magnetic flux linked with the coil changes. This change in magnetic flux will lead to generation of induced current. The direction of the induced current, as given by Fleming's Right Hand Rule, is along ABCD in the coil and in the outer circuit it flows from  $B_2$  to  $B_1$ . During the second half of rotation, the direction of current is along DCBA in the coil and in the outer circuit it flows from  $B_1$  to  $B_2$ . As the rotation of the coil continues, the induced current in the external circuit is changing its direction for every half a rotation of the coil.

To get a direct current (DC), a split ring type commutator must be used. With this arrangement,



one brush is at all times in contact with the arm moving up in the field while the other is in contact with the arm moving down. Thus, a unidirectional current is produced. The generator is thus called a DC generator (Figure 5.19).

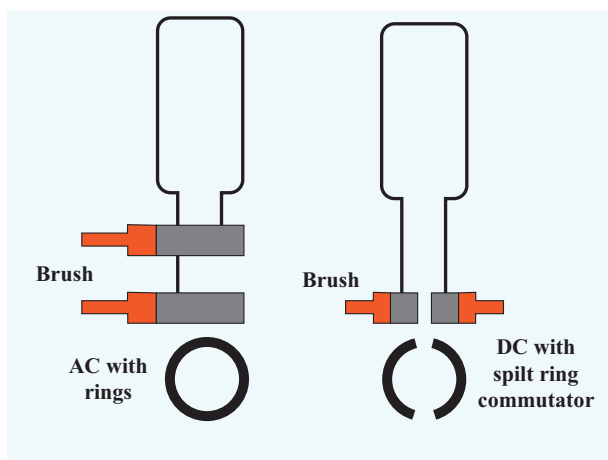

**Figure 5.19** Comparison of AC and DC generators

## 5.9 Transformer

Transformer is a device used for converting low voltage into high voltage and high voltage into low voltage. It works on the principle of electromagnetic induction. It consists of primary and secondary coil insulated from each other. The alternating current flowing through the primary coil induces magnetic field in the iron ring. The magnetic field of the iron ring induces a varying emf in the secondary coil.

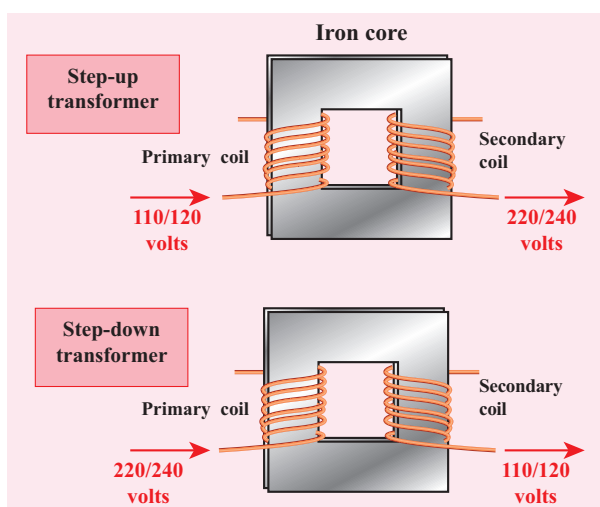

**Figure 5.20** Step up and step down transformers

Depending upon the number of turns in the primary and secondary coils, we can step-up or step-down the voltage in the secondary coil as shown in Figure 5.20.

**Step up transformer:** The transformer used to change a low alternating voltage to a high alternating voltage is called a step up transformer. ie  $V_s > V_p$ . In a step up transformer, the number of turns in the secondary coil is more than the number of turns in the primary coil ( $N_s > N_p$ ).

**Step down transformer:** The transformer used to change a high alternating voltage to a low alternating voltage is called a step down transformer ( $V_s < V_p$ ). In a step down transformer, the number of turns in the secondary coils are less than the number of turns in the primary coil ( $N_s < N_p$ ).



A step up transformer increases the voltage but it decreases the current and vice versa. Basically there will be loss of energy in a transformer in the form of heat, sound etc.

The formulae pertaining to the transformers are given in the following equations.

$$\frac{\text{Number of primary turns } N_p}{\text{Number of secondary turns } N_s} = \frac{\text{Primary voltage } V_p}{\text{Secondary voltage } V_s}$$

$$\frac{\text{Number of secondary turns } N_s}{\text{Number of primary turns } N_p} = \frac{\text{Primary current } I_p}{\text{Secondary current } I_s}$$

A transformer cannot be used with the direct current (DC) source because, current in the primary coil is constant (ie. DC). Then there will be no change in the number of magnetic field lines linked with the secondary coil and hence no emf will be induced in the secondary coil.

### Problem 3

The primary coil of a transformer has 800 turns and the secondary coil has 8 turns. It is connected to a 220 V ac supply. What will be the output voltage?

Solution:

In a transformer,  $E_s / E_p = N_s / N_p$

$$E_s = N_s / N_p \times E_p$$

$$= 8/800 \times 220 = 220/100 = 2.2 \text{ volt}$$

## 5.10 Applications of Electromagnets

Electromagnetism has created a great revolution in the field of engineering applications. In addition, this has caused a great impact on various fields such as medicine, industries, space etc.

### 5.10.1 Speaker

Inside the speaker, an electromagnet is placed in front of a permanent magnet. The permanent magnet is fixed firmly in position whereas the electromagnet is mobile. As pulses of electricity pass through the coil of the electromagnet, the direction of its magnetic field is rapidly changed. This means that it is in turn attracted to and repelled from the permanent magnet vibrating back and forth. The electromagnet is attached to a cone made of a flexible material such as paper or plastic which amplifies these vibrations, pumping sound waves into the surrounding air towards our ears.

### 5.10.2 Magnetic Levitation Trains

Magnetic levitation (Maglev) is a method by which an object is suspended with no support other than magnetic fields. In maglev trains two sets of magnets are used, one set to repel and push the train up off the track, then another set to move the floating train ahead at great speed without friction. In this

technology, there is no moving part. The train travels along a guideway of magnets which controls the train's stability and speed using the basic principles of magnets.



Figure 5.21 Magnetic Levitation Trains

### 5.10.3 Medical System

Nowadays electromagnetic fields play a key role in advanced medical equipments such as hyperthermia treatments for cancer, implants and magnetic resonance imaging (MRI). Sophisticated equipments working based on electromagnetism can scan even minute details of the human body.



Figure 5.22 MRI Scanning machine

Many of the medical equipments such as scanners, x-ray equipments and other equipments also use the principle of electromagnetism for their functioning.



### Points to Remember

- ❖ When current passes through a wire a magnetic field is set up around the wire. This is called magnetic effect of current.
- ❖ The space surrounding a bar magnet in which its influence in the form of magnetic force can be detected, is called magnetic field.
- ❖ The path along which a free magnetic north pole will move in a magnetic field is called magnetic field lines.
- ❖ The magnetic field set up by a current carrying conductor is always at right angles to the direction of flow of current.
- ❖ Two parallel wires carrying current in the same directions attract each other.
- ❖ Two parallel wires carrying current in the opposite directions repel each other.
- ❖ Direction of the force in a current carrying conductor is determined by Fleming's Left Hand Rule.
- ❖ Electric motor is a device which converts electrical energy into mechanical energy.
- ❖ The phenomenon of producing induced current in a closed circuit due to the change in magnetic field in the circuit is known as electromagnetic induction.
- ❖ Direction of induced current in a conductor is determined by Fleming's Right Hand Rule.
- ❖ Electric generator is a device used to convert mechanical energy into electrical energy.
- ❖ Electric generator works on the principle of electromagnetic induction.
- ❖ Transformer converts low alternating current to high alternating current and vice versa.

### A-Z GLOSSARY

<b>Magnetic field</b>	The region surrounding a magnet in which the force of the magnet can be detected.
<b>Magnetic line of force</b>	The path followed by a magnetic needle in a magnetic field.
<b>Dynamo</b>	Device which converts mechanical energy into electrical energy.
<b>Motor</b>	Device which converts electrical energy into mechanical energy.
<b>Electromagnetic induction</b>	The phenomenon of producing an induced emf due to change in the magnetic lines of forces associated with a conductor.
<b>Transformer</b>	Device which converts low alternating current to high alternating current and vice versa.
<b>MRI</b>	Devis used to obtain images of the internal parts of our body.



### TEXTBOOK EXERCISES



#### I. Choose the correct answer.

1. Which of the following converts electrical energy into mechanical energy?
  - a) Motor
  - b) Battery
  - c) Generator
  - d) Switch
2. Transformer works on
  - a) AC only
  - b) DC only
  - c) Both AC and DC
3. The part of the AC generator that passes the current from the armature coil to the external circuit is
  - a) field magnet
  - b) split rings
  - c) slip rings
  - d) brushes

4. The unit of magnetic flux density is
  - a) Weber
  - b) weber/metre
  - c) weber/meter<sup>2</sup>
  - d) weber . meter<sup>2</sup>

## II. Fill in the blanks.

1. The SI Unit of magnetic field induction is \_\_\_\_\_.
2. Devices which is used to convert high alternating current to low alternating current is \_\_\_\_\_.
3. An electric motor converts \_\_\_\_\_.
4. A device for producing electric current is \_\_\_\_\_.

## III. Match the following.

- |                              |               |
|------------------------------|---------------|
| 1. Magnetic material         | (a) Oersted   |
| 2. Non-magnetic material     | (b) Iron      |
| 3. Current and magnetism     | (c) Induction |
| 4. Electromagnetic induction | (d) Wood      |
| 5. Electric generator        | (e) Faraday   |

## IV. State whether true or false. If false, correct the statement.

1. A generator converts mechanical energy into electrical energy.
2. Magnetic field lines always repel each other and do not intersect.
3. Fleming's Left hand rule is also known as Dynamo rule.
4. The speed of rotation of an electric motor can be increased by decreasing the area of the coil.
5. A transformer can step up direct current.
6. In a step down transformer the number of turns in primary coil is greater than that of the number of turns in the secondary coil.

## V. Answer in brief.

1. State Fleming's Left Hand Rule.
2. Define magnetic flux density.
3. List the main parts of an electric motor.
4. Draw and label the diagram of an AC generator.
5. State the advantages of ac over dc.
6. Differentiate step up and step down transformer.
7. A portable radio has a built in transformer so that it can work from the mains instead of batteries. Is this a step up or step down transformer? Give reason.
8. State Faraday's laws of electromagnetic induction.

## VI. Answer in detail.

1. Explain the principle, construction and working of a dc motor.
2. Explain two types of transformer.
3. Draw a neat diagram of an AC generator and explain its working.



## REFERENCE BOOKS

Advanced Physics by Keith Gibbs – Cambridge University Press.

Principles of physics (Extended) – Halliday Resnick and Walker. Wiley publication, New Delhi.

Fundamental University Physics – M. Alonso, E. J. Finn Addison Wesley (1967)



## INTERNET RESOURCES

[www.physicsabout.com](http://www.physicsabout.com)

<https://science.howstuffworks.com>

<http://arvindguptatoys.com/films.html>

## Concept Map

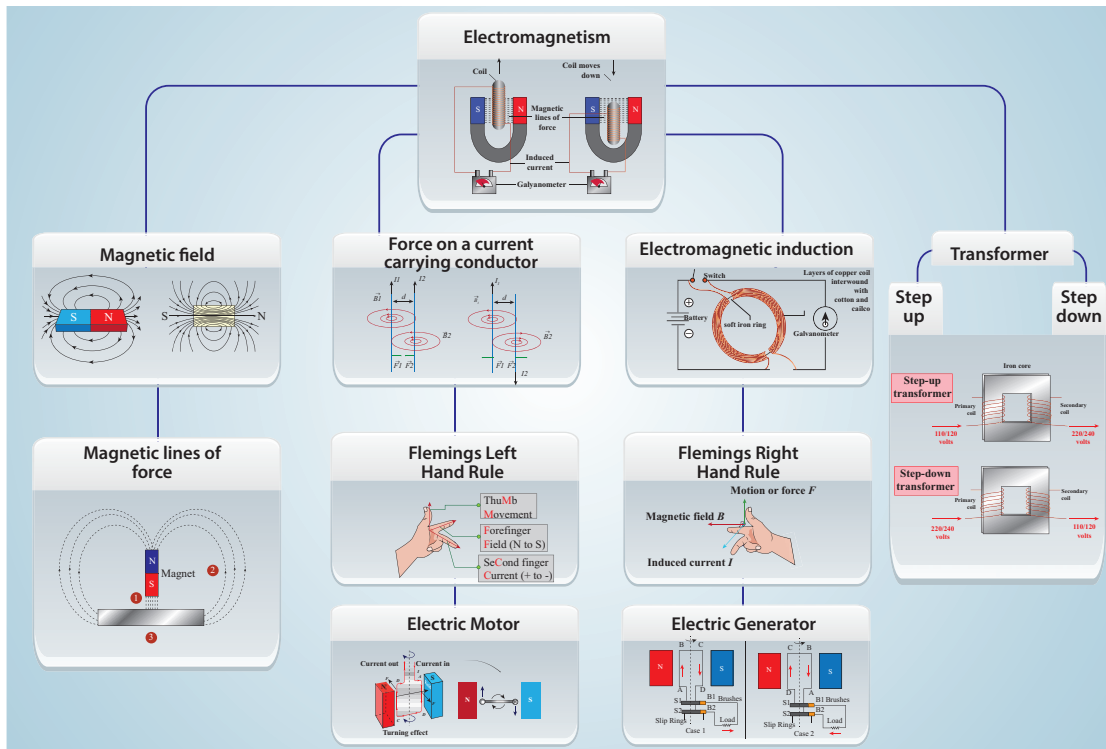

ICT CORNER

## Magnetism and Electromagnetism

Explore this activity to know about the various properties in magnetism

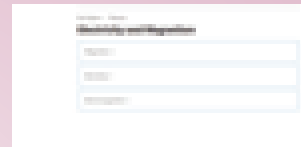

### Steps

- Copy and paste the link given below or type the URL in the browser. Click the option **Magnet and Compass**.
- You can find six activities and three videos related to magnets and loudspeaker.
- Click any one of the six activities to simulate and understand the process.
- Click any one of the three videos to understand the concepts related to loudspeaker and magnets. Try all the other activities and videos as well.

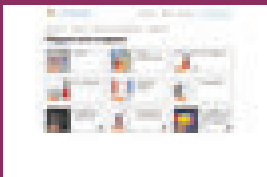

Step1



Step2



Step3

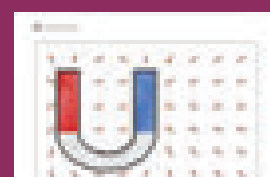

Step4

Browse in the link:

URL: <http://www.edumedia-sciences.com/en/node/75-magnetism>

\*Pictures are indicative only



B567\_9\_SCI\_EM\_T3



## Learning Objectives

After completing this lesson, students will be able to:

- apply the laws of reflection for plane mirrors and spherical mirrors.
- draw ray diagrams to find the position and size of the image for spherical mirrors.
- distinguish between real and virtual images.
- apply the mirror equation to calculate position, size and nature of images for spherical mirrors.
- identify the direction of bending when light passes from one medium to another.
- solve problems using Snell's law.
- predict whether light will be refracted or undergo total internal reflection.

## Introduction

Light is a form of energy which travels as electromagnetic waves. The branch of physics that deals with the properties and applications of light is called *optics*. In our day to day life we use number of optical instruments. Microscopes are inevitable in science laboratories. Telescopes, binoculars, cameras and projectors are used in educational, scientific and entertainment fields.

In this lesson, you will learn about spherical mirrors (concave and convex). Also, you will learn about the properties of light, namely reflection and refraction and their applications.

## 6.1 Reflection of Light

Light falling on any polished surface such as a mirror, is reflected. This reflection of light on polished surfaces follows certain laws and you

have studied about them in your lower classes. Let us study about them little elaborately here.

### 6.1.1 Laws of reflection

Consider a plane mirror  $MM'$  as shown in Figure 6.1. Let  $AO$  be the light ray incident on the plane mirror at  $O$ . The ray  $AO$  is called incident ray. The plane mirror reflects the incident ray along  $OB$ . The ray  $OB$  is called reflected ray. Draw a line  $ON$  at  $O$  perpendicular to  $MM'$ . This line  $ON$  is called normal.

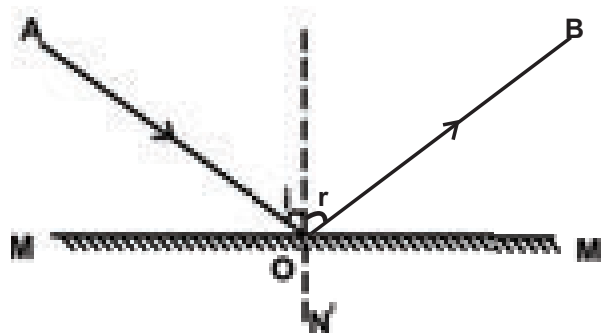

Figure 6.1 Plane mirror



The angle made by the incident ray with the normal ( $i = \text{angle AON}$ ) is called angle of incidence. The reflected ray OB makes an angle ( $r = \text{angle NOB}$ ) with the normal and this is called angle of reflection. From the figure you can observe that the angle of incidence is equal to the angle of reflection. i.e.,  $\angle i = \angle r$ . Also, the incident ray, the reflected ray and the normal at the point of incidence all lie in the same plane. These are called the laws of reflection. Laws of reflection are given as:

- The incident ray, the reflected ray and the normal at the point of incidence, all lie in the same plane.
- The angle of incidence is equal to angle of reflection.



The most common usage of mirror writing can be found on the front of ambulances, where the word "AMBULANCE" is often written in very large mirrored text.

### 6.1.2 Lateral inversion

You might have heard about inversion. But what is lateral inversion? The word lateral comes from the Latin word *latus* which means side. Lateral inversion means sidewise inversion. It is the apparent inversion of left and right that occurs in a plane mirror.

Why do plane mirrors reverse left and right, but they do not reverse up and down? Well, the answer is surprising. Mirrors do not actually reverse left and right and they do not reverse up and down also. What actually mirrors do is reverse inside out.

Look at the image below (Figure 6.2) and observe the arrows, which indicate the light ray from the object falling on the mirror. The arrow from the object's head is directed towards the top of the mirror and the arrow from the feet is directed towards the bottom. The arrow from left hand goes to the left side of the mirror and

the arrow from the right hand goes to the right side of the mirror. Here, you can see that there is no switching. It is an optical illusion. Thus, the apparent lateral inversion we observe is not caused by the mirror but the result of our perception.



Figure 6.2 Lateral inversion

## 6.2 Real and Virtual Image

If the light rays coming from an object actually meet, after reflection, the image formed will be a real image and it is always inverted. A real image can be produced on a screen.

When the light rays coming from an object do not actually meet, but appear to meet when produced backwards, that image will be virtual image. The virtual image is always erect and cannot be caught on a screen (Figure 6.3).

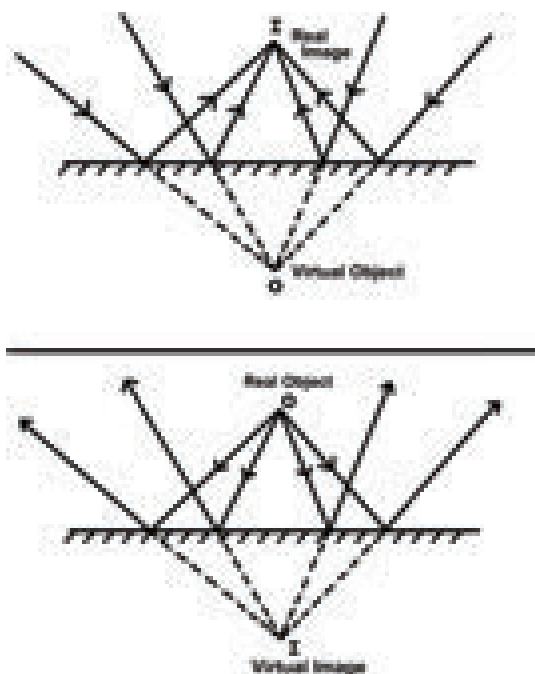

Figure 6.3 Real and virtual image



### Activity 1

Stand before the mirror in your dressing table or the mirror fixed in a steel almirah. Do you see your whole body? To see your entire body in a mirror, the mirror should be at least half of your height. Height of the mirror = Your height/2.

## 6.3 Curved Mirrors

We studied about laws of reflection. These laws are applicable to all types of reflecting surfaces including curved surfaces. In your earlier classes, you have studied that there are many types of curved mirrors, such as spherical and parabolic mirrors. The most commonly used type of curved mirror is spherical mirror.



### 6.3.1 Spherical mirrors

In curved mirrors, the reflecting surface can be considered to form a part of the surface of a sphere. Such mirrors whose reflecting surfaces are spherical are called spherical mirrors.

In some spherical mirrors the reflecting surface is curved inwards, that is, it faces towards the centre of the sphere. They are called concave mirrors. In some other mirrors, the reflecting surface is curved outward. They are called convex mirror.

### 6.3.2 Image formed by spherical mirrors

### Activity 2

Hold a concave mirror in your hand (or place it in a stand). Direct its reflecting surface towards the sun. Direct the light reflected by the mirror onto a sheet of paper held not very far from the mirror. Move the sheet of paper back and forth gradually until you find a bright, sharp spot of light on the paper. Position the mirror and the paper at the same location for few moments. What do you observe? Why does the paper catches fire?

We saw that the parallel rays of sun light could be focused at a point using a concave mirror. Now let us place a lighted candle and a white screen in front of the concave mirror. Adjust the position of the screen. Move the screen front and back. Note the size of the image and its shape. You can see a small and inverted image.

Slowly bring the candle closer to the mirror. What do you observe? As you bring the object closer to the mirror the image becomes bigger. Try to locate the image when you bring the candle very close to the mirror. Are you able to see an image on the screen? Now look inside the mirror. What do you see? An erect magnified image of the candle is seen. In some positions of the object an image is obtained on the screen. However, at some positions of the object no image is obtained. It is clear that the behaviour of the concave mirror is much more complicated than the plane mirror.

However, with the use of geometrical technique we can simplify and understand the behaviour of the image formed by a concave mirror. In the case of plane mirror, we used only two rays to understand how to get full image of a person. But, for understanding the nature of image formed by a spherical mirrors we need to look at four specific rules.

### 6.3.3 Rules for the construction of image

To find the position and nature of the image formed by a spherical mirror, we need to know the following rules.

**Rule 1:** A ray passing through the centre of curvature is reflected back along its own path (Figure 6.4).

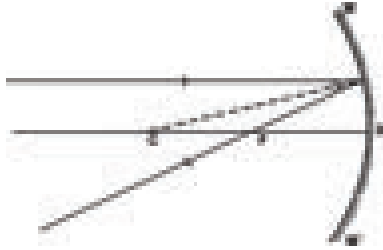

Figure 6.4 Ray passing through centre of curvature





**Rule 2:** A ray parallel to the principal axis passes through or appears to be coming from the principal focus (in case of convex mirror) after reflection (Figure 6.5).



**Figure 6.5** Ray parallel to principal axis

**Rule 3:** A ray passing through the focus gets reflected and travels parallel to the principal axis (Figure 6.6).

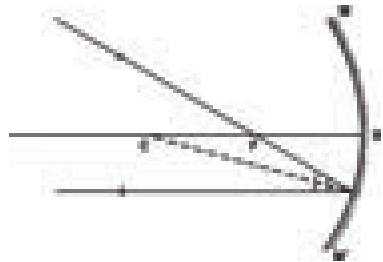

**Figure 6.6** Ray travelling through the principal focus

**Rule 4:** A ray incident at the pole of the mirror gets reflected along a path such that the angle of incidence (APC) is equal to the angle of reflection (BPC) (Figure 6.7).

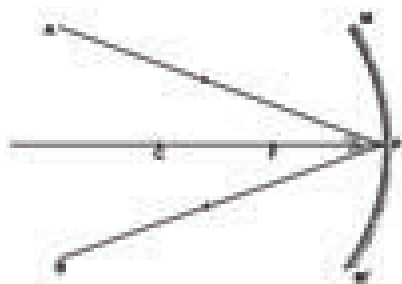

**Figure 6.7** Angle of incidence equal to angle of reflection

## 6.4 Concave Mirror

### 6.4.1 Image Formation

We shall now find the position, size and nature of image by drawing the ray diagram for

a small linear object placed on the principal axis of a concave mirror at different positions.

**Case-I:** When the object is far away (at infinity), the rays of light reaching the concave mirror are parallel to each other (Figure 6.8a).

**Position of the Image:** The image is formed at the principal focus F.

**Nature of the Image:** It is real, inverted and highly diminished in size.

**Case-II:** When the object is beyond the centre of curvature (Figure 6.8b).

**Position of the image:** Between the principal focus F and centre of curvature C.

**Nature of the image:** Real, inverted and smaller than object.

**Case - III:** When the object is at the centre of curvature (Figure 6.8c).

**Position of the image:** The image is at the centre of curvature itself.

**Nature of the image:** It is real, inverted and same size as the object.

**Case - IV:** When the object is in between the centre of curvature C and principal focus F (Figure 6.8d).

**Position of the image:** The image is beyond C

**Nature of the image:** It is real inverted and magnified.

**Case - V:** When the object is at the principal focus F (Figure 6.8e).

**Nature of the image:** No image can be captured on the screen nor any virtual image can be seen.

**Case - VI:** When the object is in between the focus F and the pole P (Figure 6.8f).

**Position of the image:** The image is behind the mirror.

**Nature of the image:** It is virtual, erect and magnified.

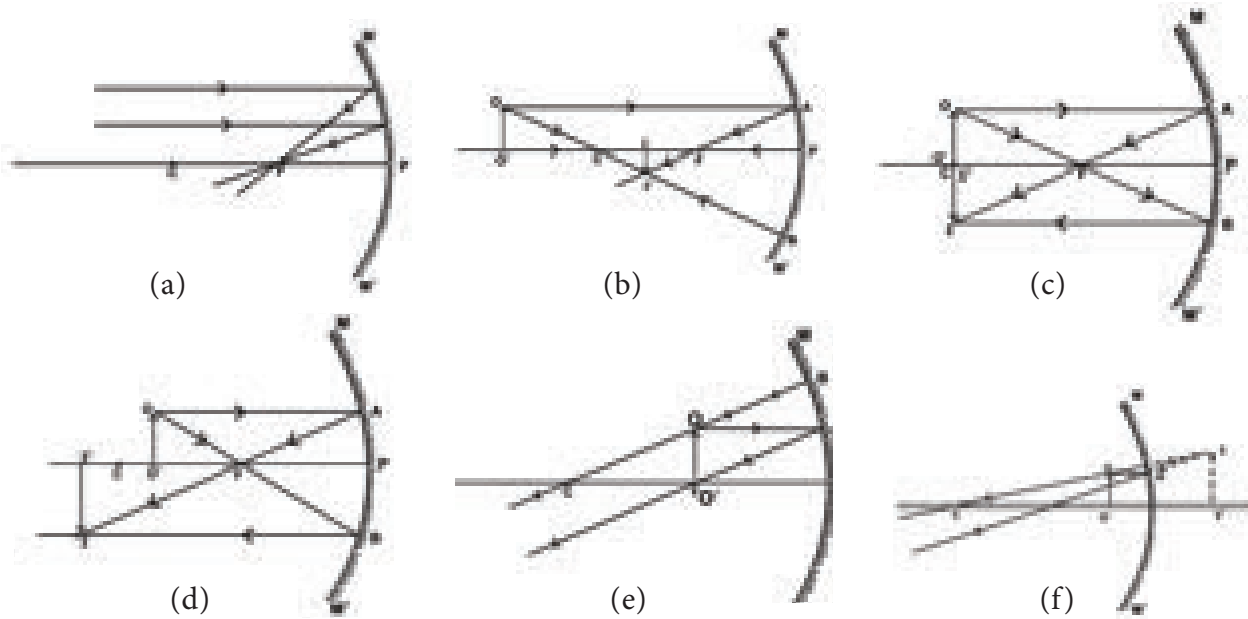

**Figure 6.8** Ray diagram for the images formed by concave mirror

### 6.4.2 Sign convention for measurement of distances

We follow a set of sign conventions called the cartesian sign convention to measure distances in ray diagram. In this convention, the pole (P) of the mirror is taken as the origin. The principal axis is taken as the X-axis of the coordinate system (Figure 6.9).

- The object is always placed on the left side of the mirror.
- All distances are measured from the pole of the mirror.
- Distances measured in the direction of incident light are taken as positive and those measured in the opposite direction are taken as negative.

- All distances measured perpendicular to and above the principal axis are considered to be positive.
- All distances measured perpendicular to and below the principal axis are considered to be negative.

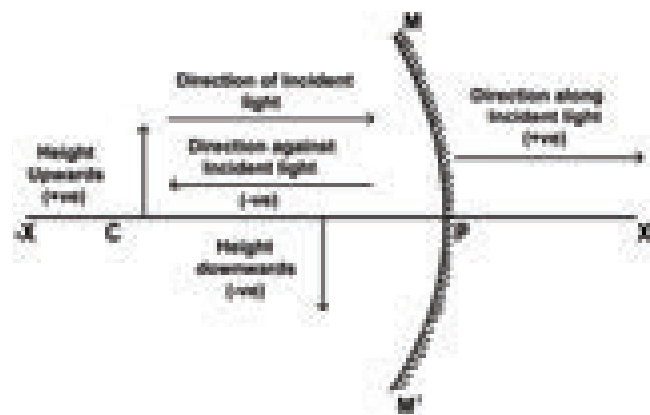

**Figure 6.9** Sign convention for spherical mirrors

**Table 6.1** Sign convention for spherical mirrors.

Type of mirror	u	v		f	R	Height of the object	Height of the image	
		real	virtual				real	virtual
Concave mirror	-	-	+	-	-	+	-	+
Convex mirror	-	No real image	+	+	+	+	No real image	+



### 6.4.3 Mirror equation

The expression relating the distance of the object ( $u$ ), distance of the image ( $v$ ) and the focal length ( $f$ ) of a spherical mirror is called the mirror equation. It is given as:

$$\frac{1}{f} = \frac{1}{u} + \frac{1}{v}$$

### 6.4.4 Linear magnification ( $m$ )

Magnification produced by a spherical mirror gives how many times the image of an object is magnified with respect to the object size.

It can be defined as the ratio of the height of the image ( $h_i$ ) to the height of the object ( $h_o$ ).

$$m = \frac{h_i}{h_o}$$

The magnification can be related to object distance ( $u$ ) and the image distance ( $v$ ).

$$m = -\frac{v}{u}$$
$$\therefore m = \frac{h_i}{h_o} = -\frac{v}{u}$$

**Note:** A negative sign in the value of magnification indicates that the image is real. A positive sign in the value of magnification indicates that the image is virtual.

#### Problem 1

Find the size, nature and position of the image formed when an object of size 1 cm is placed at a distance of 15 cm from a concave mirror of focal length 10 cm.

#### Solution:

Object distance,  $u = -15$  cm (to the left of mirror)

Image distance,  $v = ?$

Focal length,  $f = -10$  cm (concave mirror)

Using mirror formula,

$$\frac{1}{v} + \frac{1}{u} = \frac{1}{f}$$

$$\frac{1}{v} + \frac{1}{-15} = \frac{1}{-10}$$

$$\frac{1}{v} - \frac{1}{15} = \frac{-1}{10}$$

$$\frac{1}{v} = \frac{-1}{10} + \frac{1}{15} = \frac{-3+2}{30} = \frac{-1}{30}$$

Thus, image distance,  $v = -30$  cm (negative sign indicates that the image is on the left side of the mirror).

$\therefore$  Position of image is 30 cm in front of the mirror. Since the image is in front of the mirror, it is real and inverted.

To find the size of the image, we have to calculate the magnification.

$$m = \frac{-v}{u} = \frac{-(-30)}{(-15)} = -2$$

We know that,  $m = \frac{h_2}{h_1}$

Here, height of the object  $h_1 = 1$  cm

$$-2 = \frac{h_2}{1}$$

$$h_2 = -2 \times 1 = -2 \text{ cm}$$

The height of image is 2 cm (negative sign shows that the image is formed below the principal axis).

#### Problem 2

An object 2 cm high is placed at a distance of 16 cm from a concave mirror which produces a real image 3 cm high. Find the position of the image.

#### Solution:

Height of object  $h_1 = 2$  cm

Height of real image  $h_2 = -3$  cm

Magnification  $m = \frac{h_2}{h_1} = \frac{-3}{2} = -1.5$

We know that,  $m = \frac{-v}{u}$

Here, object distance  $u = -16$  cm



Substituting the value, we get

$$-1.5 = -\frac{v}{(-16)}$$

$$-1.5 = \frac{v}{16}$$

$$v = 16 \times (-1.5) = -24 \text{ cm}$$

The position of image is 24 cm in front of the mirror (negative sign indicates that the image is on the left side of the mirror).

### 6.4.5 Uses of concave mirror

**Dentist's head mirror:** In dentist's head mirror, a parallel beam of light is made to fall on the concave mirror. This mirror focuses the light beam on a small area of the body (such as teeth, throat etc.).

**Make-up mirror:** When a concave mirror is held near the face, an upright and magnified image is seen. Here, our face will be seen magnified.

**Other applications:** Concave mirrors are also used as reflectors in torches, head lights in vehicles and search lights to get powerful beams of light. Large concave mirrors are used in solar heaters.



Stellar objects are at an infinite distance. Therefore, the image formed by a concave mirror would be diminished, and inverted. Yet, astronomical telescopes use concave mirrors.

## 6.5 Convex Mirror

### 6.5.1 Image Formation

Any two rays can be chosen to draw the position of the image in a convex mirror (Figure 6.10): a ray that is parallel to the principal axis (rule 1) and a ray that appears to pass through the centre of curvature (rule 2).

**Note:** All rays behind the convex mirror shall be shown with dotted lines.

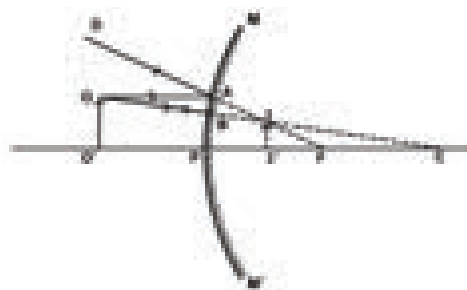

**Figure 6.10** Image formation in a convex mirror

The ray OA parallel to the principal axis is reflected along AD. The ray OB retraces its path. The two reflected rays diverge but they appear to intersect at I when produced backwards. Thus II' is the image of the object OO'. It is virtual, erect and smaller than the object.

### Activity 3

Take a convex mirror. Hold it in one hand. Hold a pencil close to the mirror in the upright position in the other hand. Observe the image of the pencil in the mirror. Is the image erect or inverted? Is it diminished or enlarged? Move the pencil slowly away from the mirror. Does the image become smaller or larger? What do you observe?



### 6.5.2 Uses of convex mirrors

Convex mirrors are used as rear-view mirrors in vehicles. It always forms a virtual, erect, small-sized image of the object. As the vehicles approach the driver from behind, the size of the image increases. When the vehicles are moving away from the driver, then image size decreases. A convex mirror provides a much wider field of view (it is the observable area as seen through eye / any optical device such as mirror) compared to plane mirror.

Convex mirrors are installed on public roads as traffic safety device. They are used in acute bends of narrow roads such as hairpin bends in mountain passes where direct view of

oncoming vehicles is restricted. It is also used in blind spots in shops.



In the rear view mirror, the following sentence is written. "Objects in the mirror are closer than they appear". Why?

### Problem 3

A car is fitted with a convex mirror of focal length 20 cm. Another car is 6 m away from the first car. Find the position of the second car as seen in the mirror of the first. What is the size of the image if the second car is 2 m broad and 1.6 m high?

#### Solution:

Focal length = 20 cm (convex mirror)

Object distance =  $-6\text{m} = -600\text{ cm}$

Image distance  $v = ?$

$$\frac{1}{f} = \frac{1}{u} + \frac{1}{v}$$

$$\frac{1}{20} = \frac{1}{-600} + \frac{1}{v}$$

$$\frac{1}{v} = \frac{1}{20} - \frac{1}{-600} = \frac{1}{20} + \frac{1}{600} = \frac{30+1}{600} = \frac{31}{600}$$

$$v = \frac{600}{31} = 19.35\text{ cm}$$

b) Size of the image

$$m = \frac{-v}{u} = -\frac{v}{(-u)} = -\frac{600}{31} \times \frac{1}{-600} = \frac{1}{31}$$

$$\text{Breadth of image} = \frac{1}{31} \times 200\text{ cm} = 6.45\text{ cm}$$

$$\text{Height of image} = \frac{1}{31} \times 160\text{ cm} = 5.16\text{ cm}$$

## 6.6 Speed of light

In early seventeenth century, the Italian scientist Galileo Galilee (1564-1642) tried to measure the speed of light.

In 1665, the Danish astronomer Ole Roemer first estimated the speed of light by observing one of the twelve moons of the planet Jupiter. He estimated the speed of light to be about 220,000 km per second.



Some organisms can make their own light too? This ability is called bioluminescence.

Worms, fish, squid, starfish and some other organisms that live in the dark sea habitat glow or flash light to scare off predators.

In 1849, the first land based estimate was made by Armand Fizeau. Today the speed of light in vacuum is known to be almost exactly 300,000 km per second.

## 6.7 Refraction of light

### Activity 4

#### Refraction of light at air – water interface

Put a straight pencil into a tank of water or beaker of water at an angle of  $45^\circ$  and look at it from one side and above. How does the pencil look now? The pencil appears to be bent at the surface of water.



This activity explains the refraction of light. The bending of light rays when they pass obliquely from one medium to another medium is called refraction of light. Light rays get deviated from their original path while entering from one transparent medium to another medium of different optical density. This deviation (change in direction) in the path of light is due to the change in velocity of light in the different medium. The velocity of light depends on the nature of the medium

in which it travels. Velocity of light is more in a rarer medium (low optical density) than in a denser medium (high optical density).

### 6.7.1 Refraction of light from a plane transparent surface

When a ray of light travels from optically rarer medium to optically denser medium, it bends towards the normal. (Figure 6.11a).

When a ray of light travels from an optically denser medium to an optically rarer medium it bends away from the normal. (Figure 6.11b).

A ray of light incident normally on a denser medium, goes without any deviation. (Figure 6.11c).

### 6.7.2 The laws of refraction of light

Laws of refraction, also known as Snell's law of refraction are given below as:

- The incident ray, the refracted ray and the normal to the interface of two transparent media at the point of incidence, all lie in the same plane.
- The ratio of the sine of the angle of incidence to the sine of the angle of refraction is a constant for a light of given colour and for the given pair of media.

If  $i$  is the angle of incidence and  $r$  is the angle of refraction, then

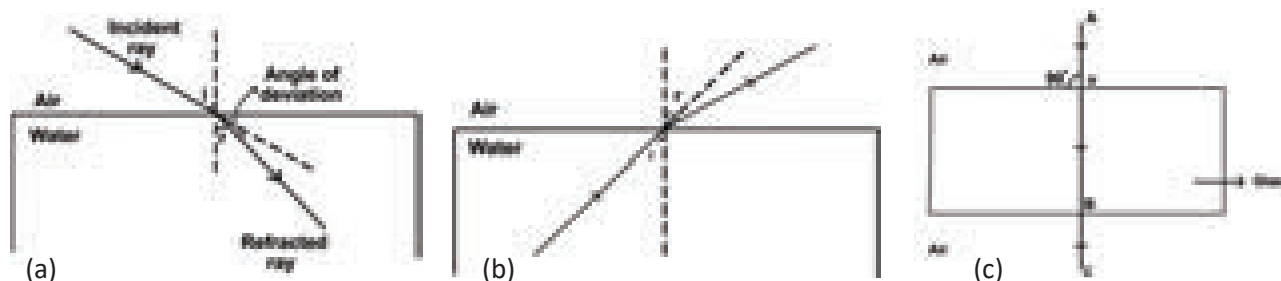

Figure 6.11 Refraction of light from a plane transparent surface

$$\frac{\sin i}{\sin r} = \text{constant}$$

This constant is called the refractive index of the second medium with respect to the first medium. It is generally represented by the Greek letter,  ${}_1\mu_2$  (mew).

**Note:** The refractive index has no unit as it is the ratio of two similar quantities.

The refractive index of a medium is also defined in terms of speed of light in different media.

$$\mu = \frac{\text{Speed of light in vacuum or air } (c)}{\text{Speed of light in the medium } (v)}$$

$$\text{In general, } {}_1\mu_2 = \frac{\text{Speed of light in medium 1}}{\text{Speed of light in medium 2}}$$

#### Problem 4

The speed of light in air is  $3 \times 10^8 \text{ ms}^{-1}$  and in glass it is  $2 \times 10^8 \text{ ms}^{-1}$ . What is the refractive index of glass?

**Solution:**

$${}_a\mu_g = \frac{3 \times 10^8}{2 \times 10^8} = \frac{3}{2} = 1.5$$

#### Problem 5

Light travels from a rarer medium to a denser medium. The angles of incidence and refraction are respectively  $45^\circ$  and  $30^\circ$ . Calculate the refractive index of the second medium with respect to the first medium.

**Solution:**

$${}_1\mu_2 = \frac{\sin i}{\sin r} = \frac{\sin 45^\circ}{\sin 30^\circ} = \frac{1/\sqrt{2}}{1/2} = \sqrt{2} = 1.414$$

## 6.8 Total Internal Reflection

When light travels from denser medium into a rarer medium, it gets refracted away from the normal. While the angle of incidence in the denser medium increases the angle of refraction also increases and it reaches a maximum value of  $r = 90^\circ$  for a particular value. This angle of incidence is called critical angle (Figure 6.12). The angle of incidence at which the angle of refraction is  $90^\circ$  is called the critical angle. At this angle, the refracted ray grazes the surface of separation between the two media.

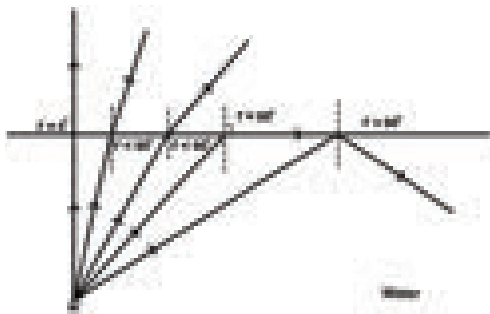

Figure 6.12 Critical angle

When the angle of incidence exceeds the value of critical angle, the refracted ray is not possible. Since  $r > 90^\circ$  the ray is totally reflected back to the same medium. This is called as total internal reflection.

### 6.8.1 Conditions to achieve total internal reflection

In order to achieve total internal reflection the following conditions must be met.

- Light must travel from denser medium to rarer medium. (Example: From water to air).
- The angle of incidence inside the denser medium must be greater than that of the critical angle.

### 6.8.2 Total internal reflection in nature

**Mirage:** On hot summer days, patch of water may be on the road. This is an illusion. In

summer, the air near the ground becomes hotter than the air at higher levels. Hotter air is less dense, and has smaller refractive index than the cooler air.

Thus, a ray of light bends away from the normal and undergoes total internal reflection. Total internal reflection is the main cause for the spectacular brilliance of diamonds and twinkling of stars.

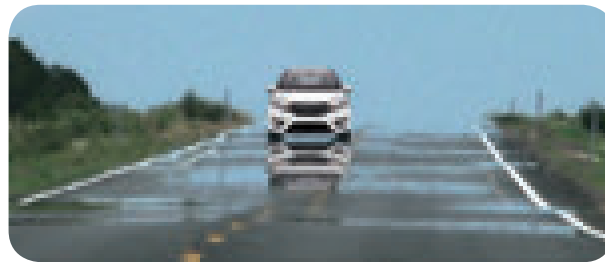

Figure 6.13 Mirage

**Optical fibres:** Optical fibres are bundles of high-quality composite glass/quartz fibres. Each fibre consists of a core and cladding. The refractive index of the material of the core is higher than that of the cladding. Optical fibres work on the phenomenon of total internal reflection. When a signal in the form of light is directed at one end of the fibre at a suitable angle, it undergoes repeated total internal reflection along the length of the fibre and finally comes out at the other end.

Optical fibres are extensively used for transmitting audio and video signals through long distances. Moreover, due to their flexible nature, optical fibers enable physicians to look and work inside the body through tiny incisions without having to perform surgery.

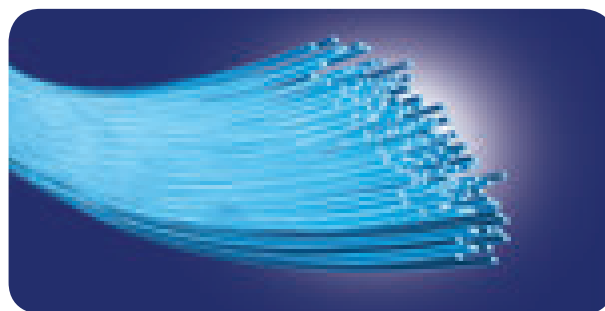

Figure 6.14 Optical fibres



An Indian-born physicist Narinder Kapany is regarded as the *Father of Fibre Optics*.

### Points to Remember

- ❖ Light is a form of energy which produces the sensation of sight.
- ❖ Laws of reflection: i) Angle of incidence is equal to the angle of reflection ii) The incident ray, the normal to the point of incidence and the reflected ray, all lie in the same plane.
- ❖ The distance between the pole and the principal focus of the spherical mirror is called focal length.  $f = \frac{R}{2}$ ; where R is the radius of curvature of the mirror.
- ❖ Mirror equation: The relation between u, v and f of a spherical mirror is known as mirror formula  $\frac{1}{u} + \frac{1}{v} = \frac{1}{f}$

- ❖ Magnification:  $m = \frac{\text{height of the image } h_2}{\text{height of the object } h_1}$
- ❖ Laws of refraction: The incident ray, the refracted ray and the normal to the surface separating two medium lie in the same plane. The ratio of the sine of the incident angle ( $\angle i$ ) to the sine of the refracted angle ( $\angle r$ ) is constant i.e.  $\mu = \frac{\sin i}{\sin r} = \text{constant}$
- ❖ The bending of light when it passes obliquely from transparent medium to another is called refraction.
- ❖ When the angle of incidence exceeds the value of critical angle the refracted ray is impossible. Since  $r > 90^\circ$  refraction is impossible and the ray is totally reflected back to the same medium (denser medium). This is called as total internal reflection.

## A-Z GLOSSARY

<b>Spherical Mirror</b>	A reflecting surface which is a part of a sphere whose inner or outer surface is reflecting.
<b>Concave Mirror</b>	Part of a hollow sphere whose outer part is silvered and/or inner part is the reflecting surface.
<b>Convex Mirror</b>	Part of a hollow sphere whose inner part is silvered and/or outer part is the reflecting surface.
<b>Centre of curvature</b>	The centre of the hollow sphere of which the spherical mirror forms a part.
<b>Radius of curvature</b>	The radius of the hollow sphere of which the spherical mirror forms a part.
<b>Pole</b>	The midpoint of the spherical mirror.
<b>Aperture</b>	The diameter of the circular rim of the mirror.
<b>Principal axis</b>	The normal to the centre of the mirror is called the principal axis.
<b>Principal focus</b>	The point on the principal axis of the spherical mirror where the rays of light parallel to the principal axis meet or appear to meet after reflection from the spherical mirror.





## TEXTBOOK EXERCISES



### I. Choose the correct answer.

- A ray of light passes from one medium to another medium. Refraction takes place when angle of incidence is  
a)  $0^\circ$     b)  $45^\circ$     c)  $90^\circ$
- \_\_\_\_\_ is used as reflectors in torchlight.  
a) Concave mirror    b) Plane mirror  
c) Convex mirror
- We can create enlarged, virtual images with  
a) concave mirror    b) plane mirror  
c) convex mirror
- When the reflecting surface is curved outwards the mirror formed will be  
a) concave mirror    b) convex mirror  
c) plane mirror
- When a beam of white light passes through a prism it gets  
a) reflected    b) only deviated  
c) deviated and dispersed
- The speed of light is maximum in  
a) vacuum    b) glass    c) diamond

### II. State whether true or false. If false, correct the statement.

- The angle of deviation depends on the refractive index of the glass.
- If a ray of light passes obliquely from one medium to another, it does not suffer any deviation.
- The convex mirror always produces a virtual, diminished and erect image of the object.
- When an object is at the centre of curvature of concave mirror the image formed will be virtual and erect.
- The reason for brilliance of diamonds is total internal reflection of light.

### III. Fill in the blanks.

- In going from a rarer to denser medium, the ray of light bends \_\_\_\_\_.

- The mirror used in search light is \_\_\_\_\_.
- The angle of deviation of light ray in a prism depends on the angle of \_\_\_\_\_.
- The radius of curvature of a concave mirror whose focal length is 5cm is \_\_\_\_\_.
- Large \_\_\_\_\_ mirrors are used to concentrate sunlight to produce heat in solar furnaces.

### IV. Match the following.

Ratio of height of image to height of object.	Concave mirror
Used in hairpin bends in mountains.	Total internal reflection
Coin inside water appearing slightly raised.	Magnification
Mirage	Convex mirror
Used as Dentist's mirror.	Refraction

### V. Assertion and reason type questions.

Mark the correct choice as:

- If both assertion and reason are true and reason is the correct explanation.
  - If both assertion and reason are true and reason is not the correct explanation.
  - If assertion is true but reason is false.
  - If assertion is false but reason is true.
- Assertion: For observing the traffic at a hairpin bend in mountain paths a plane mirror is preferred over convex mirror and concave mirror.  
Reason: A convex mirror has a much larger field of view than a plane mirror or a concave mirror.
  - Assertion: Incident ray is directed towards the centre of curvature of

spherical mirror. After reflection it retraces its path.

Reason: Angle of incidence ( $i$ ) = Angle of reflection ( $r$ ) =  $0^\circ$ .

#### VI. Answer very briefly.

1. According to cartesian sign convention, which mirror and which lens has negative focal length?
2. Name the mirror(s) that can give (i) an erect and enlarged image, (ii) same sized, inverted image.
3. If an object is placed at the focus of a concave mirror, where is the image formed?
4. Why does a ray of light bend when it travels from one medium to another?
5. What is the speed of light in vacuum?
6. Concave mirrors are used by dentists to examine teeth. Why?

#### VII. Answer briefly.

1. a) Complete the diagram to show how a concave mirror forms the image of the object.  
b) What is the nature of the image?

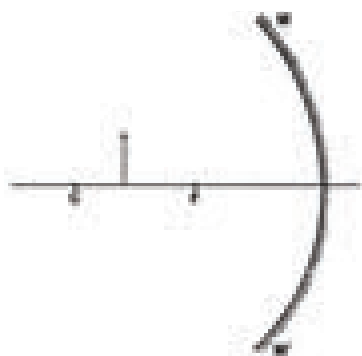

2. Pick out the concave and convex mirrors from the following and tabulate them.  
Rear-view mirror, Dentist's mirror, Torch-light mirror, Mirrors in shopping malls, Make-up mirror.
3. State the direction of incident ray which after reflection from a spherical mirror retraces its path. Give reason for your answer.

4. What is meant by magnification? Write its expression. What is its sign for real image and virtual image?
5. Write the spherical mirror formula and explain the meaning of each symbol used in it.

#### VIII. Answer in detail.

1. a) Draw ray diagrams to show how the image is formed using a concave mirror, when the position of object is: i) at C ii) between C and F iii) between F and P of the mirror.  
b) Mention the position and nature of image in each case.
2. Explain with diagrams how refraction of incident light takes place from  
a) rarer to denser medium b) denser to rarer medium c) normal to the surface separating the two media.

#### IX. Numerical problems.

1. A concave mirror produces three times magnified real image of an object placed at 7 cm in front of it. Where is the image located? (Ans: 21 cm in front of the mirror)
2. Light enters from air into a glass plate having refractive index 1.5. What is the speed of light in glass? (Ans:  $2 \times 10^8 \text{ ms}^{-1}$ )
3. The speed of light in water is  $2.25 \times 10^8 \text{ ms}^{-1}$ . If the speed of light in vacuum is  $3 \times 10^8 \text{ ms}^{-1}$ , calculate the refractive index of water. (Ans: 1.33)

#### X. Higher Order Thinking Skills.

1. Light ray emerges from water into air. Draw a ray diagram indicating the change in its path in water.
2. When a ray of light passes from air into glass, is the angle of refraction greater than or less than the angle of incidence?
3. What do you conclude about the speed of light in diamond. if the refractive index of diamond is 2.41?

## REFERENCE

1. Optics – Brijlal and Subramaniam (1999) Sultan chand Publishers.
2. Optics – Ajay Ghotak Dharyaganj Publishing circle, New Delhi.
3. Physics for entertainment – Book 2 Yakov Perelman, Mir Publishers.

## INTERNET RESOURCES

www.Physics.org  
<https://www.geogebra.org/m/aJuUDA9Z>  
<http://www.animations.physics.unsw.edu.au/light/geometrical-optics/>  
<http://www.splung.com/content/sid/4/page/snellslaw>

### Concept Map

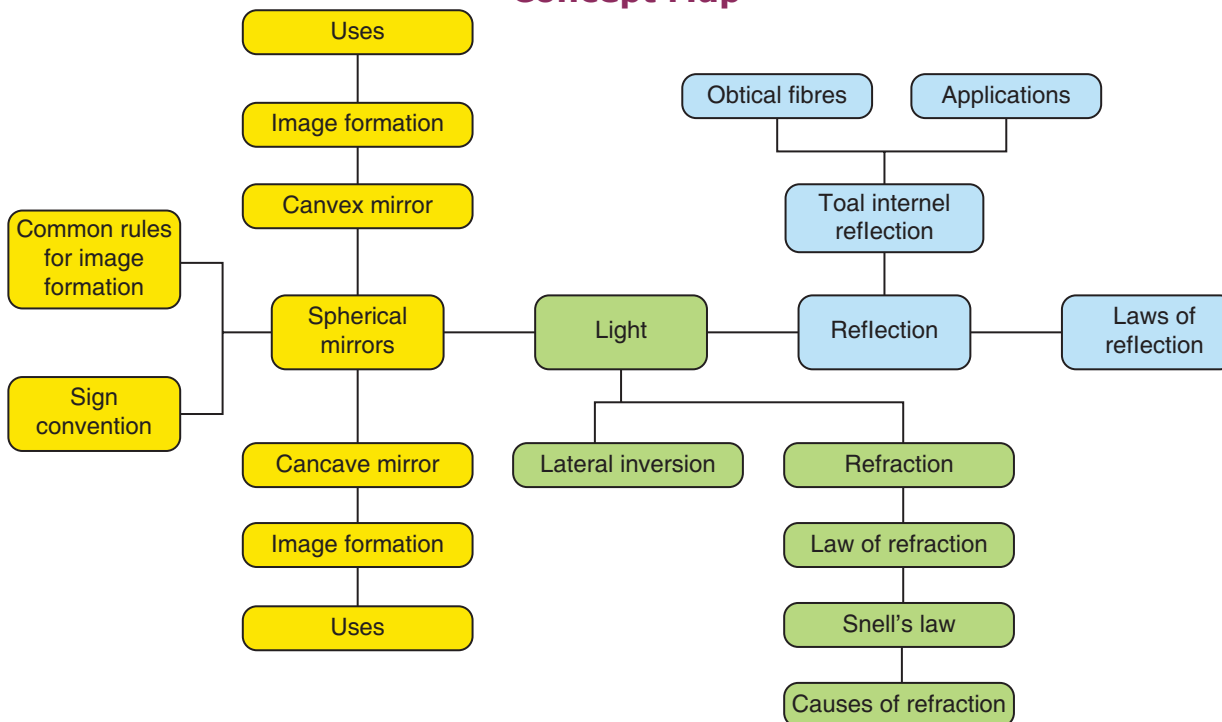

### ICT CORNER

### LIGHT - REFRACTION

Refraction is bending of light when travel from one medium to another

This activity enable the students to learn about the different mediums and its role in refraction of light

Step 1. Type the following URL in the browser or scan the QR code from your mobile. You can see “Bending light” on the screen. Click intro

Step 2. Now you can see light beam from the torch. Options are there in the four corners. Select options of your choice and then press the button in the torch. You can see the phenomono of refraction. The angles of refraction differ for different medium. You can check it with the protractor

Step 3. Next select prism. Now explore with given tools and different mediums and come out with different results



B567\_9\_SCI\_EM\_T3

[https://phet.colorado.edu/sims/html/bending-light/latest/bending-light\\_en.html](https://phet.colorado.edu/sims/html/bending-light/latest/bending-light_en.html)

## Learning Objectives



After completing this lesson, students will be able to:

- understand the nature and the effects of heat.
- differentiate the conducting powers of various substances.
- list out good and bad conductors of heat and their uses.
- explain conduction using kinetic theory.
- describe the experiments to show convection in fluids.
- understand the concept of radiation.
- define specific heat capacity and thermal capacity.
- describe the concept of change of state.
- define specific latent heat of fusion and specific latent heat of vaporisation.

## Introduction

All substances in our surrounding are made up of molecules. These molecules are generally at motion and possess kinetic energy. At the same time each molecule exerts a force of attraction on other molecules and so they possess potential energy. The sum of the kinetic and potential energy is called the internal energy of the molecules. **This internal energy, when flows out, is called heat energy.** This energy is more in hot substances and less in cold substances and flows from hot substances to cold substances. In this lesson you will study about how this heat transfer takes place. Also you will study about the effect of heat, heat capacity, change of state and latent heat.

### 7.1 Effects of Heat

When a substance is heated, the following things can happen.

**Expansion:** When heat is added to a substance, the molecules gain energy and vibrate and force other molecules apart. As a result, expansion takes place. You would have seen some space being left in railway tracks. It is because, during summer time, more heat causes expansion in tracks. Expansion is greater for liquids than solids and it is maximum in gases.

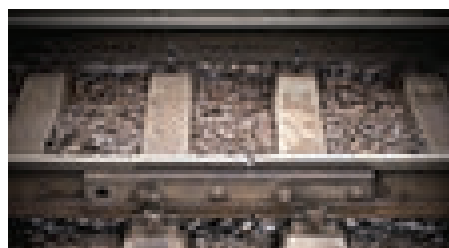

**Figure 7.1** Gap in railway track

**Change in State:** When you heat ice cubes, they become water and water on further heating changes into vapour. So, solid becomes liquid and liquid becomes gas, when heat is added. The reverse takes place when heat is removed.

**Change in Temperature:** When heat energy is added to a substance, the kinetic energy of its particles increases and so the particles move at higher speed. This causes rise in temperature. When a substance is cooled, that is, when heat is removed, the molecules lose heat and its temperature falls.

**Chemical changes:** Since heat is a form of energy it plays a major role in chemical changes. In some cases, chemical reactions need heat to begin and also heat determines the speed at which reactions occur. When we cook food, we light the wood and it catches fire and the food particles become soft because of the heat energy. These are all the chemical changes taking place due to heat.

## 7.2 Transfer of Heat

### Activity 1

Take a glass of water and put some ice cubes into it. Observe it for some time. What happens? The ice cubes melt and disappear. Why did it happen? It is because heat energy in the water is transferred to the ice.

Heat does not stay where we put it. Hot things get colder and cold things get hotter. Heat is transferred from one place to another till their temperatures become equal. Heat transfer takes place when heat energy flows from an object with higher temperature to an object with lower temperature (Fig. 7.2).

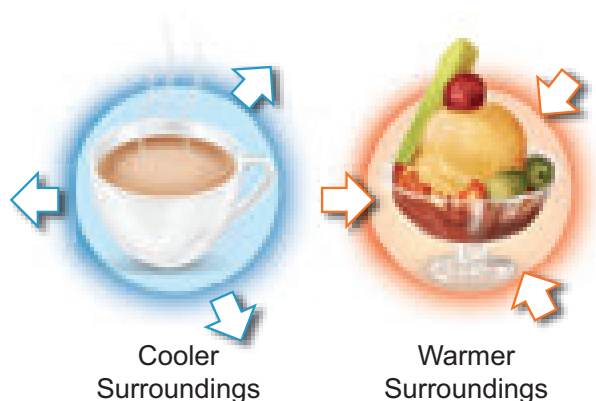

**Figure 7.2** Hot and cold surroundings



When a dog keeps out its tongue and breathes hard, the moisture on the tongue turns into water and it evaporates. Since, heat energy is needed to turn a liquid into a gas, heat is removed from dog's tongue. This helps to cool the body of the dog.

Heat transfer takes place in three ways:

- Conduction, ii. Convection, iii. Radiation

### 7.2.1 Conduction

In solids, molecules are closely arranged so that they cannot move freely. When one end of the solid is heated, molecules at that end absorb heat energy and vibrate fast at their own positions. These molecules in turn collide with the neighboring molecules and make them vibrate faster and so energy is transferred. This process continues till all the molecules receive the heat energy.

The process of transfer of heat in solids from a region of higher temperature to a region of lower temperature without the actual movement of molecules is called conduction.

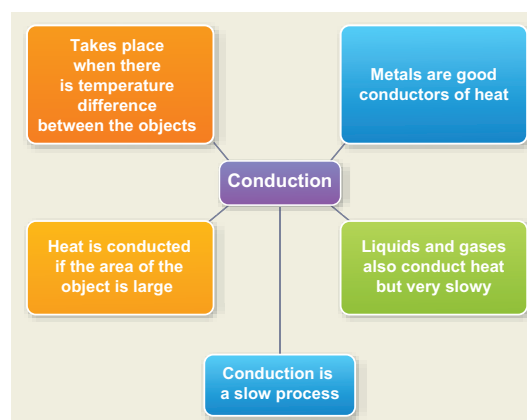

#### Conduction in daily life

- Metals are good conductors of heat. So, aluminium is used for making utensils to cook food quickly.
- Mercury is used in thermometers because, it is a good conductor of heat.
- We wear woolen clothes in winter to keep ourselves warm. Air, which is a bad conductor, does not allow our body heat to escape.

## Activity 2

Take metal rods of copper, aluminium, brass and iron. Fix a match stick to one end of each rod using a little melted wax. When the temperature of the far ends reach the melting point of wax, the matches drop off. It is observed that the match stick on the copper rod would fall first, showing copper as the best conductor followed by aluminium, brass and iron.

### 7.2.2 Convection

## Activity 3

Drop a few crystals of potassium permanganate down to the bottom of a beaker containing water. When the beaker is heated just below the crystals, by a small flame, purple streaks of water rise upwards and fan outwards.

In this activity, water molecules at the bottom of the beaker receive heat energy and move upward and replace the molecules at the top. Same thing happens in air also. When air is heated, the air molecules gain heat energy allowing them to move further apart. Warm air being less dense than cold air will rise. Cooler air moves down to replace the air that has risen. It heats up, rises and is again replaced by cooler air, creating a circular flow.

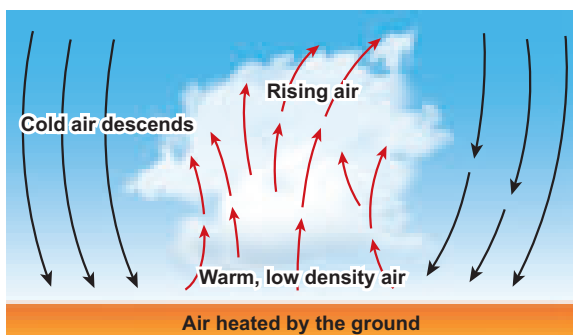

Figure 7.3 Convection in air

Convection is the flow of heat through a fluid from places of higher temperature to places of lower temperature by movement of the fluid itself.

### Convection in daily life

**Hot air balloons:** Air molecules at the bottom of the balloon get heated by a heat source and rise. As the warm air rises, cold air is pushed downward and it is also heated. When the hot air is trapped inside the balloon, it rises.



Figure 7.4 Hot air balloon

**Breezes:** During day time, the air in contact with the land becomes hot and rises. Now the cool air over the surface of the sea replaces it. It is called sea breeze. During night time, air above the sea is warmer. As the warmer air over the surface of the sea rises, cooler air above the land moves towards the sea. It is called land breeze.

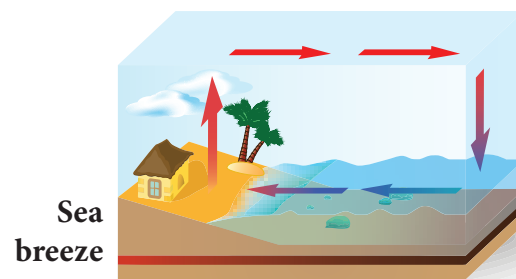

Figure 7.5 Land breeze and sea breeze



**Winds:** Air flows from area of high pressure to area of low pressure. The warm air molecules over hot surface rise and create low pressure. So, cooler air with high pressure flows towards low pressure area. This causes wind flow.

**Chimneys:** Tall chimneys are kept in kitchen and industrial furnaces. As the hot gases and smoke are lighter, they rise up in the atmosphere.

### 7.2.3 Radiation

Radiation is a method of heat transfer that does not require particles to carry the heat energy. In this method, heat is transferred in the form of waves from hot objects in all direction. Radiation can occur even in vacuum whereas conduction and convection need matter to be present. Radiation consists of electromagnetic waves travelling at the speed of light. **Thus, radiation is the flow of heat from one place to another by means of electromagnetic waves.**

Transfer of heat energy from the sun reaches us in the form of radiation. Radiation is emitted by all bodies above 0 K. Some objects absorb radiation and some other objects reflect them.



While firing wood, we can observe all the three ways of heat transfer. Heat in one end of the wood will be transferred to other end due to conduction. The air near the wood will become warm and replace the air above. This is convection. Our hands will be warm because heat reaches us in the form of radiation.

#### Radiation in daily life

- White or light colored cloths are good reflectors of heat. They keep us cool during summer.
- Base of cooking utensils is blackened because black surface absorbs more heat from the surrounding.

- Surface of airplane is highly polished because it helps to reflect most of the heat radiation from the sun.

## 7.3 Concept of Temperature

Temperature is the degree of hotness or coolness of a body. Hotter the body, higher is its temperature.

### 7.3.1 Unit of Temperature

The SI unit of temperature is *kelvin* (K). For day to day applications, *Celsius* (°C) is used. Temperature is measured with a thermometer.

### 7.3.2 Temperature scales

There are three scales of temperature.

- Fahrenheit scale
- Celsius or Centigrade scale
- Kelvin or Absolute scale

#### Fahrenheit scale

In Fahrenheit scale, 32 °F and 212 °F are the freezing point and boiling point respectively. Interval has been divided into 180 parts.

#### Celsius temperature scale

In Celsius scale, also called centigrade scale, 0°C and 100 °C are the freezing point and boiling point respectively. Interval has been divided into 100 parts. The formula to convert a Celsius scale to Fahrenheit scale is:

$$F = \frac{9}{5} C + 32$$

The formula for converting a Fahrenheit scale to Celsius scale is:

$$C = \frac{5}{9} (F - 32)$$

#### Kelvin scale (Absolute scale)

Kelvin scale is known as the absolute scale. On the Kelvin scale 0 K represents absolute zero, the temperature at which the molecules of a substance have their lowest possible energy. The solid, liquid, gaseous

phases of water can coexist in equilibrium at 273.16 K. *Kelvin is defined as 1/273.16 of the triple point temperature.* The formula for converting a Celsius scale to Kelvin scale is:

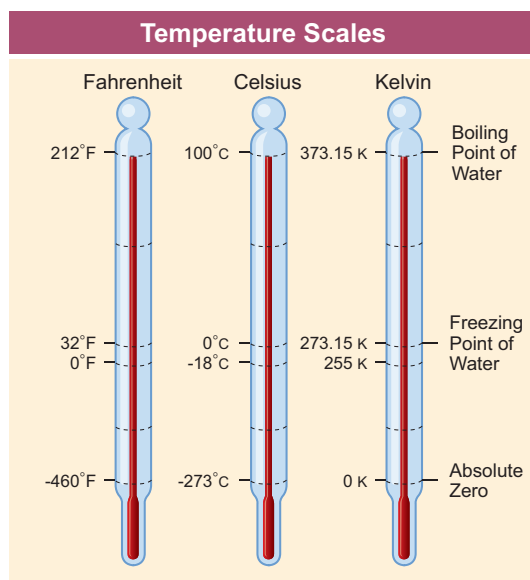
$$K = C + 273.15$$

**Figure 7.6** Types of temperature scales

### Absolute zero

The temperature at which the pressure and volume of a gas theoretically reaches zero is called absolute zero. This is shown in Figure 7.7.

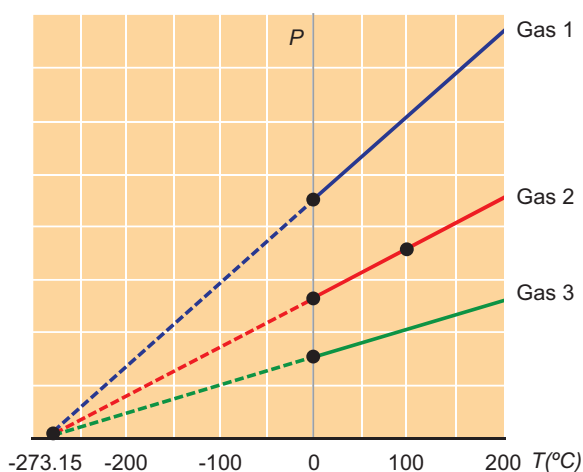

**Figure 7.7** Variation of pressure (P) with temperature (T).

For all gases, the pressure extrapolates to zero at the temperature  $-273.15\text{ }^{\circ}\text{C}$ . It is known as absolute zero or 0 K. Some base line

temperatures in the three temperature scales are shown in Table 7.1.

**Table 7.1** Baseline temperatures in three scales.

Temperature	Kelvins (K)	Degrees Celcius ( $^{\circ}\text{C}$ )	Degrees Fahrenheit ( $^{\circ}\text{F}$ )
Boiling point of water	373.15	100	212
Melting point of ice	273.15	0	32
Absolute zero	0	-273	-460

### Problem 1

Convert the following

- i.  $25\text{ }^{\circ}\text{C}$  to Kelvin    ii.  $200\text{ K}$  to  $^{\circ}\text{C}$

#### Solution:

- i.  $T_K = T_{^{\circ}\text{C}} + 273.15$   
 $T_K = 25 + 273.15 = 298.15\text{ K}$
- ii.  $T_{^{\circ}\text{C}} = T_K - 273.15$   
 $T_{^{\circ}\text{C}} = 200 - 273.15 = -73.15\text{ }^{\circ}\text{C}$

### Problem 2

Convert the following

- i.  $35\text{ }^{\circ}\text{C}$  to Fahrenheit ( $^{\circ}\text{F}$ )    ii.  $14\text{ }^{\circ}\text{F}$  to  $^{\circ}\text{C}$

#### Solution:

- i.  $T_{^{\circ}\text{F}} = T_{^{\circ}\text{C}} \times 1.8 + 32$   
 $T_{^{\circ}\text{F}} = 35\text{ }^{\circ}\text{C} \times 1.8 + 32 = 95\text{ }^{\circ}\text{F}$
- ii.  $T_{^{\circ}\text{C}} = (T_{^{\circ}\text{F}} - 32) / 1.8$   
 $T_{^{\circ}\text{C}} = (14\text{ }^{\circ}\text{F} - 32) / 1.8 = -10\text{ }^{\circ}\text{C}$

## 7.4 Specific Heat Capacity

You might have felt that the land is cool in the morning and hot during day time. But, water in a lake will be almost at a particular temperature both in the morning as well as in the afternoon. Both are subjected to same



amount of heat energy from the Sun, but they react differently. It is because both of them have different properties. In general, the amount of heat energy absorbed or lost by a body is determined by three factors.

1. Mass of the body
2. Change in temperature of the body
3. Nature of the material of the body

We can understand this from the following observations.

#### Observation: 1

Quantity of heat required to raise the temperature of 1 litre of water will be more than the heat required to raise the temperature of 500 ml of water. If  $Q$  is the quantity of heat absorbed and  $m$  is the mass of the body, then

$$Q \propto m \quad (7.1)$$

#### Observation: 2

Quantity of heat energy ( $Q$ ) required to raise the temperature of 250 ml of water to  $100^\circ\text{C}$  is more than the heat energy required to raise the temperature to  $50^\circ\text{C}$ . Here,  $Q \propto \Delta T$ , where  $\Delta T$  is the change in temperature of the body.

Thus, heat lost or gained by a substance when its temperature changes by  $\Delta T$  is,

$$Q \propto m\Delta T$$

$$Q = mC\Delta T \quad (7.2)$$

From the above equations, the absolute temperature and energy of a system are proportional to each other. The proportionality constant is the specific heat capacity ( $C$ ) of the substance.

$$\therefore C = Q/m\Delta T$$

Thus, specific heat capacity of a substance is defined as the amount of heat required to raise the temperature of 1 kg of the substance by  $1^\circ\text{C}$  or 1 K. The SI unit of specific heat capacity is  $\text{Jkg}^{-1} \text{K}^{-1}$ . The most commonly used units of specific heat capacity are  $\text{J/kg}^\circ\text{C}$  and  $\text{J/g}^\circ\text{C}$ .

Among all the substances, water has the highest specific heat capacity and its value is

$4200 \text{ J/kg}^\circ\text{K}$ . So, water absorbs a large amount of heat for unit rise in temperature. Thus, water is used as a coolant in car radiators and factories to keep engines and other machinery parts cool. It is because of this same reason, temperature of water in the lake does not change much during day time.

#### Problem 3

Calculate the heat energy required to raise the temperature of 2 kg of water from  $10^\circ\text{C}$  to  $50^\circ\text{C}$ . Specific heat capacity of water is  $4200 \text{ Jkg}^{-1} \text{K}^{-1}$ .

#### Solution:

Given  $m = 2 \text{ Kg}$ ,  $\Delta T = (50 - 10) = 40^\circ\text{C}$  In terms of Kelvin,  $\Delta T = (323.15 - 283.15) = 40\text{K}$ ,  $C = 4200 \text{ J Kg}^{-1} \text{K}^{-1}$

$$\therefore \text{Heat energy required, } Q = m \times C \times \Delta T = 2 \times 4200 \times 40 = 3,36,000 \text{ J}$$



Water in its various form, has different specific heat capacities.

Water (Liquid state)	= $4200 \text{ Jkg}^{-1} \text{K}^{-1}$
Ice (Solid state)	= $2100 \text{ Jkg}^{-1} \text{K}^{-1}$
Steam (Gaseous state)	= $460 \text{ Jkg}^{-1} \text{K}^{-1}$

## 7.5 Heat capacity or Thermal capacity

Now, you are familiar with specific heat capacity. It is the heat required to raise the temperature of a unit mass of a body by  $1^\circ\text{C}$ . But, heat capacity is the heat required to raise the temperature of the entire mass of the body by  $1^\circ\text{C}$ . Thus, heat capacity or thermal capacity is defined as the amount of heat energy required to raise the temperature of a body by  $1^\circ\text{C}$ . It is denoted by  $C'$ .

$$\text{Heat Capacity} = \frac{\text{Quantity of heat required}}{\text{Raise in Temperature}}$$

$$C' = Q/T$$

SI unit of heat capacity is J/K. It is also expressed in cal/°C, kcal/°C or J/°C.

#### Problem 4

An iron ball requires 5000 J heat energy to raise its temperature by 20 K. Calculate the heat capacity of the iron ball.

#### Solution:

Given,  $Q = 5000 \text{ J}$ ,  $\Delta T = 20 \text{ K}$

$$\begin{aligned} \text{Heat Capacity, } C &= \frac{\text{Heat energy required, } Q}{\text{Rise in temperature, } \Delta T} \\ &= \frac{5000}{20} = 250 \text{ JK}^{-1} \end{aligned}$$

## 7.5 Change of state

The process of changing of a substance from one physical state to another at a definite temperature is known as change of state.

For example, water molecules are in liquid state at normal temperature. When water is heated to 100°C, it becomes steam which is a gaseous state of matter. On reducing the temperature of the steam it becomes water again. If we reduce the temperature further to 0°C, it becomes ice which is a solid state of water. Ice on heating, becomes water again. Thus, water changes its state when there is a change in temperature. There are different such processes in the change of state in matter. Figure 7.8 shows various processes of change of state.

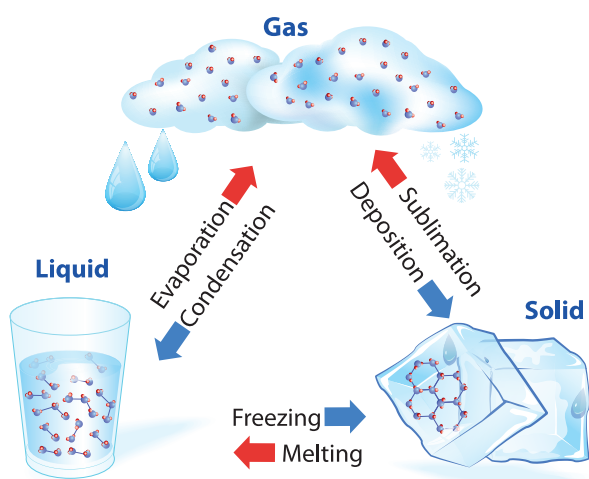

Figure 7.8 Change of state of matter

## Melting – Freezing

The process in which a solid is converted to liquid by absorbing heat is called melting or fusion. The temperature at which a solid changes its state to liquid is called melting point. The reverse of melting is freezing. The process in which a liquid is converted to solid by releasing heat is called freezing. The temperature at which a liquid changes its state to solid is called freezing point. In the case of water, melting and boiling occur at 0°C.

## Boiling-Condensation

The process in which a liquid is converted to vapor by absorbing heat is called boiling or vaporization. The temperature at which a liquid changes its state to gas is called boiling point. The process in which a vapor is converted to liquid by releasing heat is called condensation. The temperature at which vapour changes its state to liquid is called condensation point. Boiling point as well as condensation point of water is 100°C.

## Sublimation

Some solids like dry ice, iodine, frozen carbon dioxide and naphthalene balls change directly from solid state to gaseous state without becoming liquid. The process in which a solid is converted to gaseous state is called sublimation.

Various stages of conversion of state of matter by heat with the corresponding change in temperature is shown in Figure 7.9

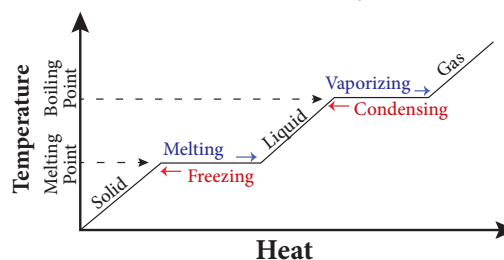

Figure 7.9 Various stages of conversion of state of matter

## 7.6 Latent heat

The word, 'latent' means hidden. So, latent heat means hidden heat or hidden energy. In order to understand latent heat, let us do the activity given below.

## Activity 4

Take some crushed ice cubes in a beaker and note down the temperature using thermometer. It will be  $0^{\circ}\text{C}$ . Now heat the ice in the beaker. You can observe that ice is melting to form water. Record the temperature at regular intervals and it will remain at  $0^{\circ}\text{C}$  until whole ice is converted to liquid. Now heat the beaker again and record the temperature. You can notice that the temperature will rise up to  $100^{\circ}\text{C}$  and it will retain the same even after continuous heating until the whole mass of water in the beaker is vaporized.

In the above activity, temperature is constant at  $0^{\circ}\text{C}$  until entire ice is converted into liquid and again constant at  $100^{\circ}\text{C}$  until all the ice is converted into vapor. Why? It is because, when a substance changes from one state to another, a considerable amount of heat energy is absorbed or liberated. This energy is called latent heat. Thus, latent heat is the amount of heat energy absorbed or released by a substance during a change in its physical states without any change in its temperature.

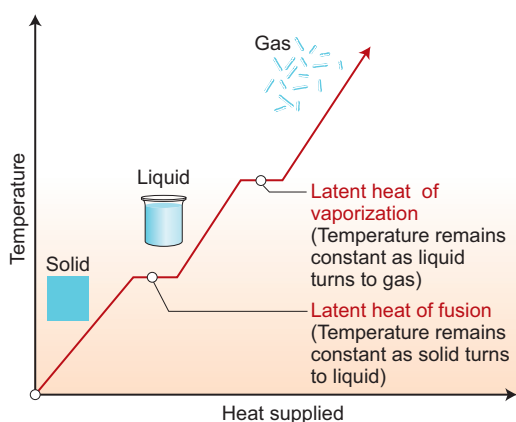

Figure 7.10 Latent heat

Heat energy is absorbed by the solid during melting and an equal amount of heat energy is liberated by the liquid during freezing, without any temperature change. It is called latent heat of fusion. In the same manner, heat energy is absorbed by a liquid during vaporization and an equal amount of heat energy is liberated by the vapor during condensation, without any

temperature changes. This is called latent heat of vaporization.

### Specific latent heat

Latent heat, when expressed per unit mass of a substance, is called specific latent heat. It is denoted by the symbol  $L$ . If  $Q$  is the amount of heat energy absorbed or liberated by 'm' mass of a substance during its change of phase at a constant temperature, then specific latent heat is given as  $L = Q/m$ .

Thus, specific latent heat is the amount of heat energy absorbed or liberated by unit mass of a substance during change of state without causing any change in temperature. The SI unit of specific latent heat is  $\text{J/kg}$ .

### Problem 5

How much heat energy is required to melt 5 kg of ice? (Specific latent heat of ice =  $336 \text{ Jg}^{-1}$ )

#### Solution:

Given,  $m = 5 \text{ Kg} = 5000\text{g}$ ,  $L = 336 \text{ Jg}^{-1}$

Heat energy required =  $m \times L$

$$= 5000 \times 336$$

$$= 1680000\text{J or } 1.68 \times 10^6 \text{ J}$$

### Problem 6

How much boiling water at  $100^{\circ}\text{C}$  is needed to melt 2 kg of ice so that the mixture which is all water is at  $0^{\circ}\text{C}$ ?

[Specific heat capacity of water =  $4.2 \text{ JKg}^{-1}$  and Specific latent heat of ice =  $336 \text{ Jg}^{-1}$ ].

#### Solution:

Given, mass of ice =  $2 \text{ kg} = 2000 \text{ g}$ .

Let 'm' be the mass of boiling water required.

Heat lost = Heat gained.

$$m \times c \times \Delta t = m \times L$$

$$m \times 4.2 \times (100 - 0) = 2000 \times 336$$

$$m = \frac{2000 \times 336}{4.2 \times 100}$$

$$= 1600 \text{ g or } 1.6 \text{ kg.}$$

### Points to Remember

- ❖ Heat is transferred from hot region to cold region.
- ❖ Heat is transferred in three forms: conduction, convection and radiation.
- ❖ Conduction takes place in solids and convection takes place in liquids and gases.
- ❖ Radiation takes place in the form of electromagnetic waves.
- ❖ There are three scales of temperature: Fahrenheit scale, Celsius or Centigrade scale and Kelvin or Absolute scale.
- ❖ Amount of heat energy absorbed or lost by a body is determined by three factors: mass of the body, change in temperature of the body, nature of the material of the body.
- ❖ The SI unit of specific heat capacity is  $\text{Jkg}^{-1} \text{K}^{-1}$ .
- ❖ Among all the substances, water has the highest specific heat capacity.
- ❖ SI unit of heat capacity is  $\text{J/K}$ .
- ❖ Depending upon the temperature, pressure and transfer of heat, matter is converted from one state to another.

### A-Z GLOSSARY

<b>Conduction</b>	Process of transfer of heat in solids from a region of higher temperature to a region of lower temperature without the actual movement of molecules.
<b>Convection</b>	Flow of heat through a fluid from places of higher temperature to places of lower temperature by movement of the fluid itself.
<b>Radiation</b>	Flow of heat from one place to another by means of electromagnetic waves.
<b>Temperature</b>	It is the degree of hotness or coolness of a body.
<b>Specific heat capacity</b>	The amount of heat required to raise the temperature of 1 kg of the substance by $1^\circ\text{C}$ or 1 K.
<b>Heat capacity</b>	The amount of heat energy required to raise the temperature of a body by $1^\circ\text{C}$ .
<b>Melting or fusion</b>	Process in which a solid is converted to liquid by absorbing heat.
<b>Freezing</b>	Process in which a liquid is converted to solid by releasing heat.
<b>Vaporization</b>	Process in which a liquid is converted to vapour by absorbing heat.
<b>Condensation</b>	Process in which a vapor is converted to liquid by releasing heat.
<b>Latent heat</b>	Amount of heat energy absorbed or released by a substance during a change in its physical state without any change in its temperature.
<b>Specific latent heat</b>	Amount of heat energy absorbed or liberated by unit mass of substance during change of state without causing any change in temperature.



### TEXT BOOK EXERCISES



#### I. Choose the correct answer.

- Calorie is the unit of
  - heat
  - work
  - temperature
  - food
- SI unit of temperature is
  - fahrenheit
  - joule
  - celsius
  - kelvin



3. Two cylindrical rods of same length have the area of cross section in the ratio 2:1. If both the rods are made up of same material, which of them conduct heat faster?  
a) Both rods      b) Rod-2  
c) Rod-1      d) None of them
4. In which mode of transfer of heat, molecules pass on heat energy to neighbouring molecules without actually moving from their positions?  
a) Radiation      b) Conduction  
c) Convection      d) Both B and C
5. A device in which the loss of heat due to conduction, convection and radiation is minimized is  
a) solar cell      b) solar cooker  
c) thermometer      d) thermos flask

## II. Fill in the blanks.

1. The fastest mode of heat transfer is \_\_\_\_\_.
2. During day time, air blows from \_\_\_\_\_ to \_\_\_\_\_.
3. Liquids and gases are generally \_\_\_\_\_ conductors of heat.
4. The fixed temperature at which matter changes state from solid to liquid is called \_\_\_\_\_.

## III. Assertion and reason type questions.

Mark the correct choice as:

- a. If both assertion and reason are true and reason is the correct explanation of assertion.
  - b. If both assertion and reason are true but reason is not the correct explanation of assertion.
  - c. If assertion is true but reason is false.
  - d. If assertion is false but reason is true.
1. **Assertion:** Food can be cooked faster in vessels with copper bottom.  
**Reason:** Copper is the best conductor of heat.

2. **Assertion:** Maximum sunlight reaches earth's surface during the noon time.

**Reason:** Heat from the sun reaches earth's surface by radiation.

3. **Assertion:** When water is heated up to  $100^{\circ}\text{C}$ , there is no raise in temperature until all water gets converted into water vapour.

**Reason:** Boiling point of water is  $10^{\circ}\text{C}$ .

## IV. Answer briefly.

1. Define conduction.
2. Ice is kept in a double-walled container. Why?
3. How does the water kept in an earthen pot remain cool?
4. Differentiate convection and radiation.
5. Why do people prefer wearing white clothes during summer?
6. What is specific heat capacity?
7. Define thermal capacity.
8. Define specific latent heat capacity.

## V. Answer in detail.

1. Explain convection in daily life.
2. What are the changes of state in water? Explain.
3. How can you experimentally prove water is a bad conductor of heat? How is it possible to heat water easily while cooking?

## VI. Numerical Problems.

1. What is the heat in joules required to raise the temperature of 25 grams of water from  $0^{\circ}\text{C}$  to  $100^{\circ}\text{C}$ ? What is the heat in Calories? (Specific heat of water =  $4.18 \text{ J/g}^{\circ}\text{C}$ )      **(Ans. 10450 J)**
2. What could be the final temperature of a mixture of 100 g of water at  $90^{\circ}\text{C}$  and 600g of water at  $20^{\circ}\text{C}$ .      **(Ans.  $30^{\circ}\text{C}$ )**
3. How much heat energy is required to change 2 kg of ice at  $0^{\circ}\text{C}$  into water at  $20^{\circ}\text{C}$ ? (Specific latent heat of fusion of water =  $3,34,000 \text{ J/kg}$ , Specific heat capacity of water =  $4200 \text{ JKg}^{-1}\text{K}^{-1}$ ).  
**(Ans. 8,36,000 J)**

## REFERENCE BOOKS

1. Mike Crundell, Geoff Goodwin and Chris Mee (2016). Cambridge International. AS and A Level physics, Second edition. Hodder Education, London.
2. Tom Duncon and Heather Kenneth(2017). Cambridge IGCSE Physics, Third edition. Hodder education, London.
3. Goyal R.P., and Tripathi S.P (2016). Concise physics, Selena publishers, New Delhi.

4. Frank New Certificate Physics. Frank Bros & co, Chennai.

## INTERNET RESOURCES

<https://betterlesson.com>

<http://www.britannica.com>

<http://study.com>

<http://www.sciencelearn.org>

## Concept Map

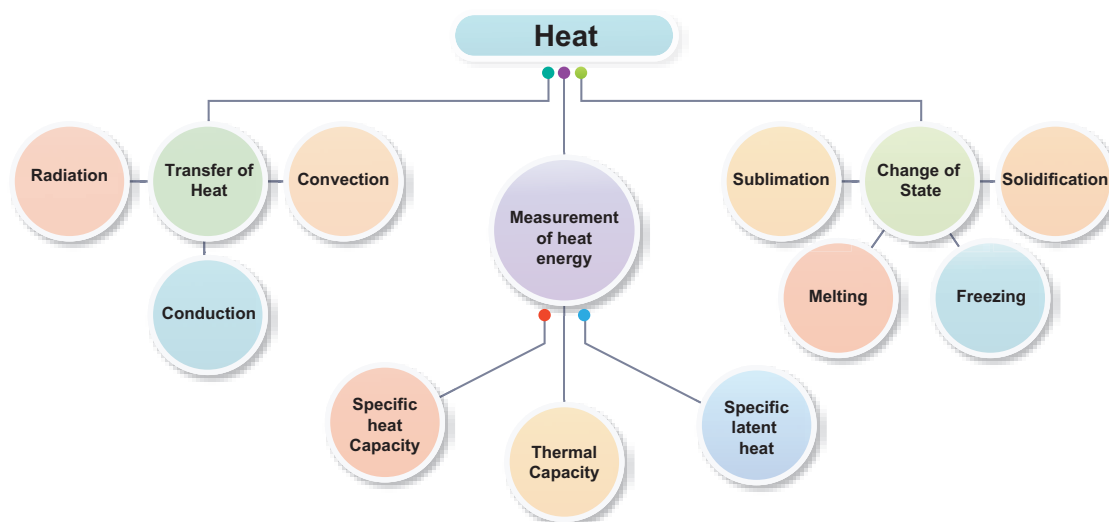

### ICT CORNER

## States of Matter - Effects of Heat changes

### Steps

- Copy and paste the link given below or type the URL in the browser. Click the option States.
- You can find Atom & Molecules with four options – Neon, Argon, Oxygen and Water. You can also find Solid, Liquid and Gas options.
- Click any one of the Atoms & Molecules to stimulate by holding the Heat or Cool option under the simulation chamber.
- You can also try the simulation by changing the Solid, Liquid and Gas options too.
- The temperature option can be changed to Fahrenheit or Celsius.

### Browse in the link:

URL: [https://phet.colorado.edu/sims/html/states-of-matter/latest/states-of-matter\\_en.html](https://phet.colorado.edu/sims/html/states-of-matter/latest/states-of-matter_en.html)

\*Pictures are indicative only



B567\_9\_SCI\_EM\_T3



## Learning Objectives

After completing this lesson, students will be able to

- understand the properties of sound.
- know that sound requires a medium to travel.
- understand that sound waves are longitudinal in nature.
- explain the characteristics of sound.
- gain knowledge about reflection of sound.
- explain ultrasonic sound and understand the applications of ultrasonic sound.

## Introduction

Sound is a form of energy which produces sensation of hearing in our ears. Some sounds are pleasant to hear and some others are not. But, all sounds are produced by vibrations of substances. These vibrations travel as disturbances in a medium and reach our ears as sound. Human ear can hear only a particular range of frequency of sound that too with a certain range of energy. We are not able to hear sound clearly if it is below certain intensity. The quality of sound also differs from one another. What are the reasons for all these? It is because sound has several qualities. In this lesson we are going to learn about production and propagation of sound along with its various other characteristics. We will also study about ultrasonic waves and their applications in our daily life.

### 8.1 Production of Sound

In your daily life you hear different sounds from different sources. But, have

you ever thought how sound is produced? To understand the production of sound, let us do an activity.

#### Activity 1

Take a tuning fork and strike its prongs on a rubber pad. Bring it near your ear. Do you hear any sound? Now touch the tuning fork with your finger. What do you feel? Do you feel vibrations?

When you strike the tuning fork on the rubber pad, it starts vibrating. These vibrations cause the nearby molecules to vibrate. Thus, vibrations produce sound.

## 8.2 Propagation of Sound Waves

### 8.2.1 Sound needs a medium for propagation

Sound needs a material medium like air, water, steel etc., for its propagation. It cannot travel through vacuum. This can be demonstrated by the Bell – Jar experiment.

An electric bell and an airtight glass jar are taken. The electric bell is suspended inside the airtight jar. The jar is connected to a vacuum pump, as shown in Figure 8.1. If the bell is made to ring, we will be able to hear the sound of the bell. Now, when the jar is evacuated with the vacuum pump, the air in the jar is pumped out gradually and the sound becomes feebler and feebler. We will not hear any sound, if the air is fully removed (if the jar has vacuum).

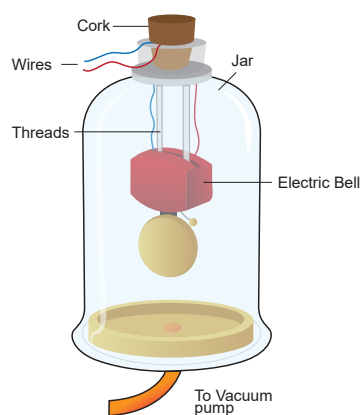

**Figure 8.1** Bell-Jar experiment

### 8.2.2 Sound is a wave

Sound moves from the point of generation to the ear of the listener through a medium. When an object vibrates, it sets the particles of the medium around to vibrate. But, the vibrating particles do not travel all the way from the vibrating object to the ear. A particle of the medium in contact with the vibrating object is displaced from its equilibrium position. It then exerts a force on an adjacent particle. As a result of which the adjacent particle gets displaced from its position of rest. After displacing the adjacent particle the first particle comes back to its original position. This process continues in the medium till the sound reaches our ears. It is to be noted that only the disturbance created by a source of sound travels through the medium not the particles of the medium. All the particles of the medium restrict themselves with only a small to and fro motion called vibration which



enables the disturbance to be carried forward. This disturbance which is carried forward in a medium is called wave.

### 8.2.3 Longitudinal nature of sound waves

#### Activity 2

Take a coil or spring and move it forward and backward. What do you observe? You can observe that in some parts of the coil the turns will be closer and in some other parts the turns will be far apart. Sound also travels in a medium in the same manner. We will study about this now.

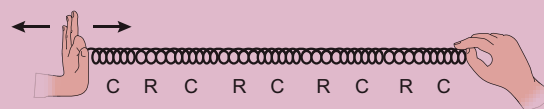

From the above activity you can see that in some parts of the coil, the turns are closer together. These are regions of compressions. In between these regions of compressions we have regions where the coil turns are far apart called rarefactions. As the coil oscillates, the compressions and rarefactions move along the coil. The waves that propagates with compressions and rarefactions are called longitudinal waves. In longitudinal waves the particles of the medium move to and fro along the direction of propagation of the wave.

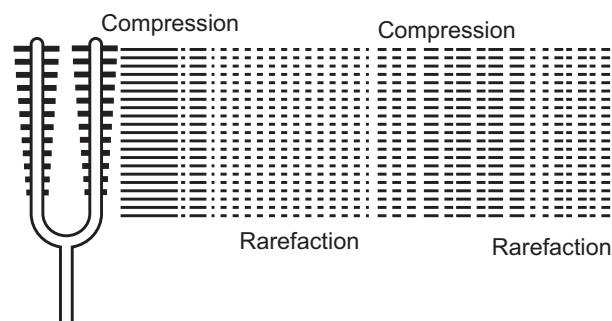

**Figure 8.2** Sound is a wave

Sound also is a longitudinal wave. Sound can travel only when there are particles which can be compressed and rarefied. Compressions are the



regions where particles are crowded together. Rarefactions are the regions of low pressure where particles are spread apart. A sound wave is an example of a longitudinal mechanical wave. Figure 8.2 represents the longitudinal nature of sound wave in the medium.

### 8.3 Characteristics of a Sound Wave

#### Activity 3

Listen to the audio of any musical instrument like *flute, nathaswaram, tabla, drums, veena* etc., Tabulate the differences between the sounds produced by the various sources.

A sound wave can be described completely by five characteristics namely amplitude, frequency, time period, wavelength and velocity or speed.

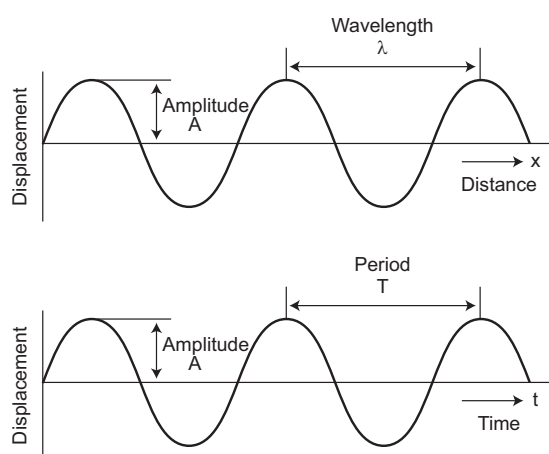

Figure 8.3 Characteristics of sound wave

#### Amplitude (A)

The maximum displacement of the particles of the medium from their original undisturbed positions, when a wave passes through the medium is called amplitude of the wave. If the vibration of a particle has large amplitude, the sound will be loud and if the vibration has small amplitude, the sound will be soft. Amplitude is denoted as A. Its SI unit is meter (m).

#### Frequency (n)

The number of vibrations (complete waves or cycles) produced in one second is called

frequency of the wave. It is denoted as n. The SI unit of frequency is  $s^{-1}$  (or) hertz (Hz). Human ear can hear sound of frequency from 20 Hz to 20,000 Hz. Sound with frequency less than 20 Hz is called infrasonic sound. Sound with frequency greater than 20,000 Hz is called ultrasonic sound. Human beings cannot hear infrasonic and ultrasonic sounds.

#### Time period (T)

The time required to produce one complete vibration (wave or cycle) is called time period of the wave. It is denoted as T. The SI unit of time period is second (s). Frequency and time period are reciprocal to each other ( $T = \frac{1}{n}$ ).

#### Wavelength (λ)

The minimum distance in which a sound wave repeats itself is called its wavelength. In a sound wave, the distance between the centers of two consecutive compressions or two consecutive rarefactions is also called wavelength. The wavelength is usually denoted as  $\lambda$  (Greek letter, lambda). The SI unit of wavelength is metre (m).

#### Velocity or speed (v)

The distance travelled by the sound wave in one second is called velocity of the sound. The SI unit of velocity of sound is  $m s^{-1}$ .

### 8.4 Distinguishing different Sounds

Sounds can be distinguished from one another in terms of the following three different factors.

1. Loudness
2. Pitch
3. Timbre (or quality)

#### 1. Loudness and Intensity

Loudness is a quantity by virtue of which a sound can be distinguished from another one, both having the same frequency. Loudness or softness of sound depends on the amplitude

of the wave. If we strike a table lightly, we hear a soft sound because we produce a sound wave of less amplitude. If we hit the table hard we hear a louder sound. Loud sound can travel a longer distance as loudness is associated with higher energy. A sound wave spreads out from its source. As it moves away from the source its amplitude decreases and thus its loudness decreases. Figure 8.4 shows the wave shapes of a soft and loud sound of the same frequency.

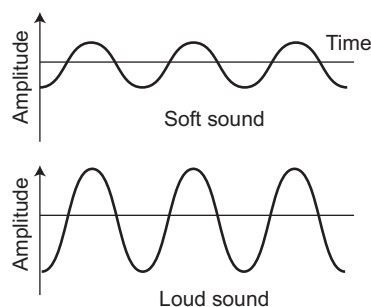

**Figure 8.4** Soft and loud sound

The loudness of a sound depends on the intensity of sound wave. Intensity is defined as the amount of energy crossing per unit area per unit time perpendicular to the direction of propagation of the wave.

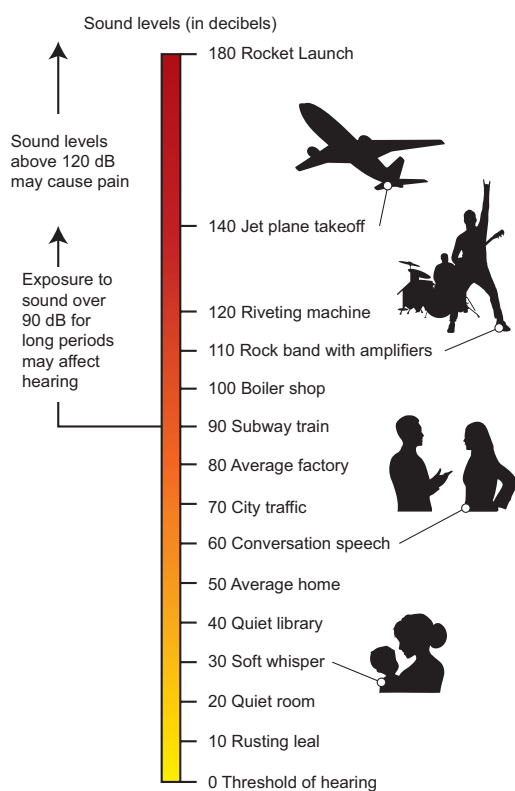

**Figure 8.5** Intensity level of sound

The intensity of sound heard at a place depends on the following five factors.

- i. Amplitude of the source.
- ii. Distance of the observer from the source.
- iii. Surface area of the source.
- iv. Density of the medium.
- v. Frequency of the source.

The unit of intensity of sound is decibel (dB). It is named in honour of the Scottish-born scientist Alexander Graham Bell who invented telephone.

## 2. Pitch

Pitch is one of the characteristics of sound by which we can distinguish whether a sound is shrill or base. High pitch sound is shrill and low pitch sound is flat. Two music sounds produced by the same instrument with same amplitude, will differ when their vibrations are of different frequencies. Figure 8.6 consists of two waves representing low pitch and high pitch sounds.

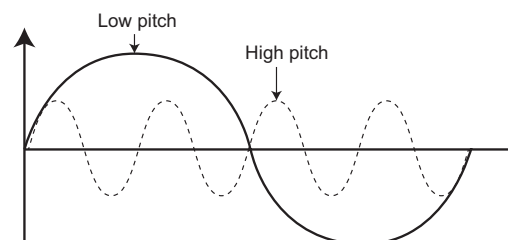

**Figure 8.6** Low pitch and high pitch sounds

## 3. Timbre or Quality

Timbre is the characteristic which distinguishes two sounds of same loudness and pitch emitted by two different instruments. A sound of single frequency is called a tone and a collection of tones is called a note. Timbre is then a general term for the distinguishable characteristics of a tone.

## 8.5 Speed of Sound

The speed of sound is defined as the distance travelled by a sound wave per unit time as it propagates through an elastic medium.

$$\text{Speed (v)} = \frac{\text{Distance}}{\text{Time}}$$

If the distance traveled by one wave is taken as one wavelength ( $\lambda$ ), and the time taken for this propagation is one time period ( $T$ ), then

$$\text{Speed (v)} = \frac{\text{One wavelength } (\lambda)}{\text{One time period (T)}} \quad (\text{or}) \quad v = \frac{\lambda}{T}$$

As,  $T = \frac{1}{n}$ , the speed ( $v$ ) of sound is also written as,  $v = n \lambda$ .

The speed of sound remains almost the same for all frequencies in a given medium under the same physical conditions.

### Problem 1

A sound wave has a frequency of 2 kHz and wavelength of 15 cm. How much time will it take to travel 1.5 km?

**Solution:**

$$\text{Speed, } v = n \lambda$$

$$\text{Here, } n = 2 \text{ kHz} = 2000 \text{ Hz}$$

$$\lambda = 15 \text{ cm} = 0.15 \text{ m}$$

$$v = 0.15 \times 2000 = 300 \text{ m s}^{-1}$$

$$\text{Time (t)} = \frac{\text{Distance (d)}}{\text{Velocity (v)}}$$

$$t = \frac{1500}{300} = 5 \text{ s}$$

The sound will take 5 s to travel a distance of 1.5 km.

### Problem 2

What is the wavelength of a sound wave in air at 20° C with a frequency of 22 MHz?

**Solution:**

$$\lambda = v/n$$

$$\text{Here, } v = 344 \text{ m s}^{-1}.$$

$$n = 22 \text{ MHz} = 22 \times 10^6 \text{ Hz}$$

$$\lambda = 344/22 \times 10^6 = 15.64 \times 10^{-6} \text{ m} = 15.64 \mu\text{m}.$$

## 8.5.1 Speed of sound in different media

Sound propagates through a medium at a finite speed. The sound of thunder is heard a little later than the flash of light is seen. So, we can make out that sound travels with a speed

which is much less than the speed of light. The speed of sound depends on the properties of the medium through which it travels.

The speed of sound is less in gaseous medium compared to solid medium. In any medium the speed of sound increases if we increase the temperature of the medium. For example the speed of sound in air is 330 m s<sup>-1</sup> at 0 °C and 340 m s<sup>-1</sup> at 25 °C. The speed of sound at a particular temperature in various media is listed in Table 8.1.

**Table 8.1** Speed of sound in different media at 25° C.

State	Medium	Speed in ms <sup>-1</sup>
Solids	Aluminum	6420
	Nickel	6040
	Steel	5960
	Iron	5950
	Brass	4700
	Glass	3980
Liquids	Water (Sea)	1531
	Water (distilled)	1498
	Ethanol	1207
	Methanol	1103
Gases	Hydrogen	1284
	Helium	965
	Air	340
	Oxygen	316
	Sulphur dioxide	213

### More to Know

**Sonic boom:** When the speed of any object exceeds the speed of sound in air (330 m s<sup>-1</sup>) it is said to be travelling at supersonic speed. Bullets, jet, aircrafts etc., can travel at supersonic speeds. When an object travels at a speed higher than that of sound in air, it produces shock waves. These shock waves carry a large amount of energy. The air pressure variations associated with this type of shock waves produce a very sharp and loud sound called the 'sonic boom'. The shock waves produced by an aircraft have energy to shatter glass and even damage buildings.



Sound travels about 5 times faster in water than in air. Since the speed of sound in sea water is very large (being about  $1530\text{ m s}^{-1}$  which is more than  $5500\text{ km/h}^{-1}$ ), two whales in the sea which are even hundreds of kilometres away can talk to each other very easily through the sea water.

## 8.6 Reflection of Sound

Sound bounces off a surface of solid or a liquid medium like a rubber ball that bounces off from a wall. An obstacle of large size which may be polished or rough is needed for the reflection of sound waves. The laws of reflection are:

- The angle in which the sound is incident is equal to the angle in which it is reflected.
- Direction of incident sound, the reflected sound and the normal are in the same plane.

### 8.6.1 Uses of multiple reflections of sound

#### Musical instruments

Megaphones, loud speakers, horns, musical instruments such as nathaswaram, shehnai and trumpets are all designed to send sound in a particular direction without spreading it in all directions. In these instruments, a tube followed by a conical opening reflects sound successively to guide most of the sound waves from the source in the forward direction towards the audience.



Figure 8.7 Megaphone or horn

#### Stethoscope

Stethoscope is a medical instrument used for listening to sounds produced in the body. In stethoscopes, these sounds reach doctor's ears by multiple reflections that happen in the connecting tube.

## More to Know

Use of ear phones for long hours can cause infection in the inner parts of the ears, apart from damage to the ear drum. Your safety is in danger if you wear ear phones while crossing signals, walking on the roads and travelling. Using earphones while sleeping is all the more dangerous as current is passing in the wires. It may even lead to mental irritation. Hence, you are advised to deter from using earphones as far as possible.



## 8.7 Echo

When we shout or clap near a suitable reflecting surface such as a tall building or a mountain, we will hear the same sound again a little later. This sound which we hear is called an echo. The sensation of sound persists in our brain for about 0.1s.

Hence, to hear a distinct echo the time interval between the original sound and the reflected sound must be at least 0.1s. Let us consider the speed of sound to be  $340\text{ m s}^{-1}$  at  $25^\circ\text{ C}$ . The sound must go to the obstacle and return to the ear of the listener on reflection after 0.1 s. The total distance covered by the sound from the point of generation to the reflecting surface and back should be at least  $340\text{ m s}^{-1} \times 0.1\text{ s} = 34\text{ m}$ .

Thus, for hearing distinct echoes, the minimum distance of the obstacle from the source of sound must be half of this distance i.e. 17 m. This distance will change with the temperature of air. Echoes may be heard more than once due to successive or multiple

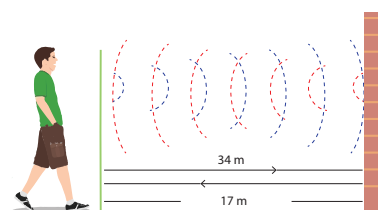

Figure 8.8 Echo

reflections. The roaring of thunder is due to the successive reflections of the sound from a number of reflecting surfaces, such as the clouds at different heights and the land.

### Problem 3

A man fires a gun and hears its echo after 5 s. The man then moves 310 m towards the hill and fires his gun again. If he hears the echo after 3 s, calculate the speed of sound.

#### Solution:

$$\text{Distance } (d) = \text{velocity } (v) \times \text{time } (t)$$

$$\text{Distance travelled by sound when gun fires first time, } 2d = v \times 5 \quad (1)$$

$$\text{Distance travelled by sound when gun fires second time, } 2d - 620 = v \times 3 \quad (2)$$

$$\text{Rewriting equation (2) as, } 2d = (v \times 3) + 620 \quad (3)$$

$$\text{Equating (1) and (3), } 5v = 3v + 620$$

$$2v = 620$$

$$\text{Velocity of sound, } v = 310 \text{ m s}^{-1}$$

## 8.8 Reverberation

A sound created in a big hall will persist by repeated reflection from the walls until it is reduced to a value where it is no longer audible. The repeated reflection that results in this persistence of sound is called reverberation. In an auditorium or big hall excessive reverberation is highly undesirable. To reduce reverberation, the roof and walls of the auditorium are generally covered with sound absorbing materials like compressed fiberboard, flannel cloths, rough plaster and draperies. The seat materials are also selected on the basis of

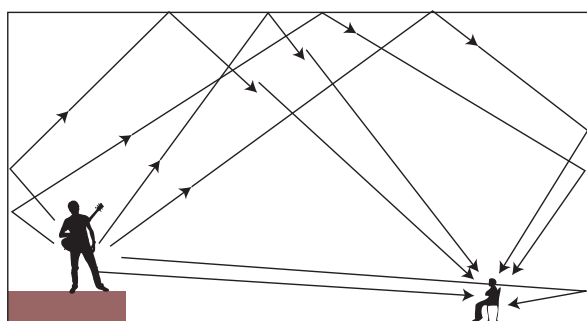

**Figure 8.9** Reverberation of sound in a auditorium

their sound absorbing properties. There is a separate branch in physics called acoustics which takes these aspects of sound in to account while designing auditoria, opera halls, theaters etc.

## 8.9 Ultrasonic Sound or Ultrasound

Ultrasonic sound is the term used for sound waves with frequencies greater than 20,000 Hz. These waves cannot be heard by the human ear, but the audible frequency range for other animals includes ultrasound frequencies. For example, dogs can hear ultrasonic sound. Ultrasonic whistles are used in cars to alert deer to oncoming traffic so that they will not leap across the road in front of cars.

An important use of ultrasound is in examining inner parts of the body. The ultrasonic waves allow different tissues such as organs and bones to be 'seen' or distinguished by bouncing of ultrasonic waves by the objects examined. The waves are detected, analysed and stored in a computer. An echogram is an image obtained by the use of reflected ultrasonic waves. It is used as a medical diagnostic tool. Ultrasonic sound is having application in marine surveying also.

### More to Know

Animals, such as bats, dolphins, rats, whales and oil birds, use echolocation, an ultrasound technique that uses echoes to identify and locate objects. Echolocation allows bats to navigate through dark caves and find insects for food. Dolphins and whales emit a rapid series of underwater clicks in ultrasonic frequencies to locate their prey and navigate through water.

### 8.9.1 Applications of ultrasonic waves

- Ultrasounds can be used in cleaning technology. Minute foreign particles can be removed from objects placed in a liquid bath through which ultrasound is passed.
- Ultrasounds can also be used to detect cracks and flaws in metal blocks.

- Ultrasonic waves are made to reflect from various parts of the heart and form the image of the heart. This technique is called 'echo cardiography'.
- Ultrasound may be employed to break small 'stones' formed in the kidney into fine grains. These grains later get flushed out with urine.

## 8.10 SONAR

SONAR stands for SOund Navigation And Ranging. Sonar is a device that uses ultrasonic waves to measure the distance, direction and speed of underwater objects. Sonar consists of a transmitter and a detector and is installed at the bottom of boats and ships.

The transmitter produces and transmits ultrasonic waves. These waves travel through water and after striking the object on the seabed, get reflected back and are sensed by the detector. The detector converts the ultrasonic waves into electrical signals which are appropriately interpreted. The distance of the object that reflected the sound wave can be calculated by knowing the speed of sound in water and the time interval between transmission and reception of the ultrasound.

Let the time interval between transmission and reception of ultrasound signal be ' $t$ '. Then, the speed of sound through sea water is  $2d/t = v$ .

### Problem 4

A ship sends out ultrasound that returns from the seabed and is detected after 3.42 s. If the speed of ultrasound through sea water is  $1531 \text{ m s}^{-1}$ , what is the distance of the seabed from the ship?

### Solution:

We know, distance = speed  $\times$  time

$$2d = \text{speed of ultrasound} \times \text{time}$$

$$2d = 1531 \times 3.42$$

$$\therefore d = \frac{5236}{2} = 2618 \text{ m}$$

Thus, the distance of the seabed from the ship is 2618 m or 2.618 km.

This method is called echo-ranging. Sonar technique is used to determine the depth of the sea and to locate underwater hills, valleys, submarine, icebergs etc.

## 8.11 Electrocardiogram (ECG)

The electrocardiogram (ECG) is one of the simplest and oldest cardiac investigations available. It can provide a wealth of useful information and remains an essential part of the assessment of cardiac patients. In ECG, the sound variation produced by heart is converted into electric signals. Thus, an ECG is simply a representation of the electrical activity of the heart muscle as it changes with time. Usually it is printed on paper for easy analysis. The sum of this electrical activity, when amplified and recorded for just a few seconds is known as an ECG.

## 8.12 Structure of Human Ear

How do we hear? We are able to hear with the help of an extremely sensitive device called the ear. It allows us to convert pressure variations in air with audible frequencies into electric signals that travel to the brain via the auditory nerve. The auditory aspect of human ear is discussed below.

The outer ear is called 'pinna'. It collects the sound from the surroundings. The collected sound passes through the auditory canal. At the end of the ear is eardrum or tympanic membrane. When a compression of the medium reaches the eardrum the pressure on the outside of the membrane increases and forces the eardrum inward. Similarly, the eardrum moves outward when a rarefaction reaches it. In this way the eardrum vibrates. The vibrations are amplified several times by three bones (the hammer, anvil and stirrup) in the middle ear. The middle ear transmits the amplified pressure variations received from the sound wave to the inner ear. In the inner ear, the pressure variations are turned into electrical signals by the cochlea. These electrical signals are

sent to the brain via the auditory nerve and the brain interprets them as sound.

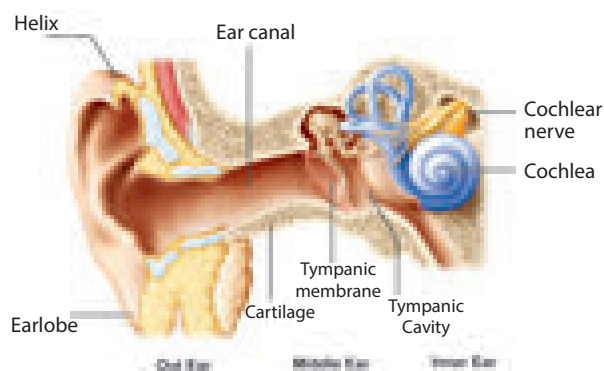

**Figure 8.10** Human ear

### Points to Remember

- ❖ Sound is produced due to vibration.
- ❖ Sound cannot travel through vacuum.
- ❖ Sound travels as a longitudinal wave through a material medium.
- ❖ Sound travels as successive compressions and rarefactions in the medium.
- ❖ In sound propagation, it is the energy of the sound that travels and not the particles of the medium.
- ❖ The speed ( $v$ ), frequency ( $n$ ), and wavelength ( $\lambda$ ), of sound are related by the equation,  $v = n \lambda$ .
- ❖ The law of reflection of sound: (i) The angle of incidence, the angle of reflection and normal drawn at the point of incidence all lie in the same plane (ii) The angle of incidence ( $i$ ) and the angle of reflection ( $r$ ) are always equal.
- ❖ The speed of sound depends primarily on the nature and the temperature of the transmitting medium.
- ❖ For hearing distinct echo sound, the time interval between the original sound and the reflected sound must be at least 0.1 s.
- ❖ The persistence of hearing sound in an auditorium is the result of repeated reflections of sound and is called reverberation.
- ❖ The amount of sound energy passing each second through unit area is called the intensity of sound.
- ❖ The audible range of hearing for average human being is in the frequency range of 20 Hz to 20000 Hz
- ❖ Sound waves with frequencies below audible range are termed as 'Infrasonics' and those above audible range are termed as 'Ultrasonics'.
- ❖ The SONAR technique is used to determine the depth of the sea and to locate under water hills, valleys, submarines, icebergs, etc.

## A-Z GLOSSARY

<b>Amplitude</b>	The maximum displacement of a particle.
<b>Compressions</b>	The region of increased pressure.
<b>Echo</b>	The repetition of sound caused by the reflection of sound.
<b>Frequency</b>	Number of waves produced in one second.
<b>Longitudinal wave</b>	The wave that propagates with compressions and rarefactions.
<b>Pitch</b>	Characteristics of sound based on frequency.
<b>Rarefactions</b>	The region of decreased pressure.
<b>Reverberation</b>	The repeated reflection that results in persistence of sound is called reverberation.
<b>Timbre (or quality)</b>	Characteristic which distinguishes the two sounds of same loudness and pitch emitted by two different instruments.
<b>Time period</b>	Time taken to produce one wave.
<b>Ultrasonic sound</b>	Sound waves with frequencies greater than 20,000 Hz.
<b>Wave</b>	The propagating disturbance that travels in a medium.
<b>Wavelength</b>	The minimum distance in which a sound wave repeats itself.



## TEXTBOOK EXERCISES



### I. Choose the correct answer.

- Which of the following vibrates when a musical note is produced by the cymbals in an orchestra?
  - stretched strings
  - stretched membranes
  - air columns
  - metal plates
- Sound travels in air:
  - if there is no moisture in the atmosphere.
  - if particles of medium travel from one place to another.
  - if both particles as well as disturbance move from one place to another.
  - if disturbance moves.
- A musical instrument is producing continuous note. This note cannot be heard by a person having a normal hearing range. This note must then be passing through
  - wax
  - vacuum
  - water
  - empty vessel
- The maximum speed of vibrations which produces audible sound will be in
  - sea water
  - ground glass
  - dry air
  - human blood
- The sound waves travel faster
  - in liquids
  - in gases
  - in solids
  - in vacuum

### II. Fill in the blanks.

- Sound is a \_\_\_\_\_ wave and needs a material medium to travel.
- Number of vibrations produced in one second is \_\_\_\_\_.
- The velocity of sound in solid is \_\_\_\_\_ than the velocity of sound in air.
- Vibration of object produces \_\_\_\_\_.

- Loudness is proportional to the square of the \_\_\_\_\_.
- \_\_\_\_\_ is a medical instrument used for listening to sounds produced in the body.
- The repeated reflection that results in persistence of sound is called \_\_\_\_\_.

### III. Match the following.

Tuning fork	The point where density of air is maximum.
Sound	Maximum displacement from the equilibrium position.
Compressions	The sound whose frequency is greater than 20,000 Hz.
Amplitude	Longitudinal wave.
Ultrasonics	Production of sound.

### IV. Answer briefly.

- Through which medium sound travels faster, iron or water? Give reason.
- Name the physical quantity whose SI unit is 'hertz'. Define.
- What is meant by supersonic speed?
- How does the sound produced by a vibrating object in a medium reach your ears?
- You and your friend are on the moon. Will you be able to hear any sound produced by your friend?

### V. Answer in detail.

- Describe with diagram, how compressions and rarefactions are produced.
- Verify experimentally the laws reflection of sound.
- List the applications of sound.
- Explain how does SONAR work?



## VI. Numerical problems.

1. The frequency of a source of sound is 600 Hz. Calculate the number of times it vibrates in a minute?
2. A stone is dropped from the top of a tower 750 m high into a pond of water at the base of the tower. Calculate the number of seconds for the splash to be heard?

(Given  $g = 10 \text{ m s}^{-2}$  and speed of sound =  $340 \text{ m s}^{-1}$ )



## REFERENCE BOOKS

1. Applied Physics – Rajasekaran S and others – Vikas Publishing House Pvt Ltd.
2. Fundamentals of Physics – Halliday, Resnick and Walker, Wiley India Pvt Ltd. NewDelhi.



## INTERNET RESOURCES

[www.britannica.com/science/ultrasonics](http://www.britannica.com/science/ultrasonics)

<https://www.searchencrypt.com>

<https://www.soundwaves.com/>

## Concept Map

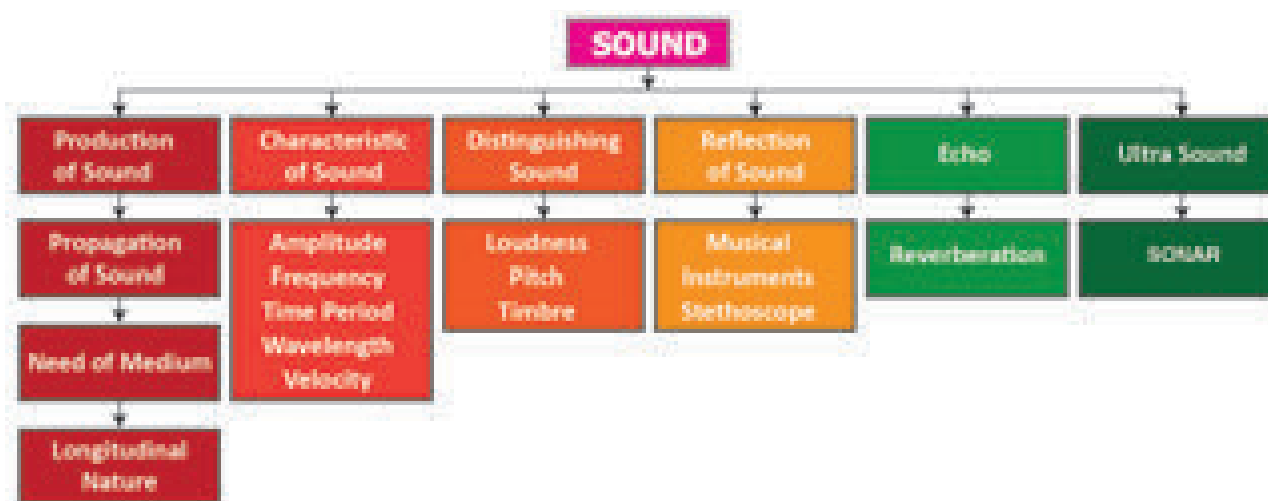

## ICT CORNER

## Sound

### Steps

- Type the given URL to reach “pHET Simulation” page and download the “java” file of Sound.
- Open the “java” file and plug in your headphone. Click “Audio enabled” box from right side to hear the sound waves.
- Switch the tabs from the top to simulate various properties of sound waves. Watch the longitudinal sound waves from different interfaces by altering “Frequency” and “Amplitude”.
- Alter “Air Density” and observe its effect on the sound waves. Use “Reset” to repeat the experiment.

### Sound Simulator

URL: <https://phet.colorado.edu/en/simulation/legacy/sound> or Scan the QR Code.



B567\_9\_SCI\_EM\_T3

## Learning Objectives

After completing this lesson, students will be able to

- know the evolution of the universe.
- understand the building blocks of the universe.
- know more about solar system.
- know Kepler's laws of motion.
- calculate the orbital velocity and the time-period of satellites.
- know about International Space Station.



## Introduction

In the earlier days, before the invention of astronomical instruments, people thought that Earth is the centre of all the objects in the space. This was known as the geocentric model, held by Greek astronomer Ptolemy (2nd Century), Indian astronomer Aryabhata (5th Century) and many astronomers around the world. Later Polish astronomer Nicolaus Copernicus proposed the heliocentric model (helios = Sun), with Sun at the centre of the solar system. Invention of the telescope in the Netherlands, in 1608, created a revolution in astronomy. In this lesson, we will study about the building blocks of the universe, Kepler's laws of motion, time period of satellites and International Space Station (ISS).

### 9.1 Building block of the Universe

The basic constituent of the universe is luminous matter i.e., galaxies which are really the collection of billions of stars. The universe

contains everything that exists including the Earth, planets, stars, space, and galaxies. This includes all matter, energy and even time. No one knows how big the universe is. It could be infinitely large. Scientists, however, measure the size of the universe by what they can see. This is called the 'observable universe'. The observable universe is around 93 billion light years (1 light year = the distance that light travels in one year, which is  $9.4607 \times 10^{12}$  km) across.

One of the interesting things about the universe is that it is currently expanding. It is growing larger and larger all the time. Not only is it growing larger, but the edge of the universe is expanding at a faster and faster rate. However, most of the universe what we think of is empty space. All the atoms together only make up around four percent of the universe. The majority of the universe consists of something scientists call dark matter and dark energy.

#### Activity 1

Form a team of three to four students. Prepare a poster about the astronomers.

### 9.1.1 Age of the Universe

Scientists think that the universe began with the start of a massive explosion called the Big Bang. According to Big Bang theory, all the matter in the universe was concentrated in a single point of hot dense matter. About 13.7 billion years ago, an explosion occurred and all the matter were ejected in all directions in the form of galaxies. Nearly all of the matter in the universe that we understand is made of hydrogen and helium, the simplest elements, created in the Big Bang. The rest, including the oxygen, the carbon, calcium, and iron, and silicon are formed in the cores of stars. The gravity that holds these stars together generally keeps these elements deep inside their interiors. When these stars explode, these fundamental building blocks of planetary systems are liberated throughout the universe.

### 9.1.2 Galaxies

Immediately after the Big Bang, clouds of gases began to compress under gravity to form the building blocks of galaxies. A galaxy is a massive collection of gas, dust, and billions of stars and their solar systems. Scientists believe that there are one hundred billion ( $10^{11}$ ) galaxies in the observable universe. Galaxies are also in different shapes. Depending on their appearance, galaxies are classified as spiral, elliptical, or irregular. Galaxies occur alone or in pairs, but they are more often parts of groups, clusters, and super clusters. Galaxies in such groups often interact and even merge together.

Our Sun and all the planets in the solar system are in the Milky Way galaxy. There are many galaxies besides our Milky Way. Andromeda galaxy is our closest neighboring galaxy. The Milky Way galaxy is spiral in shape.

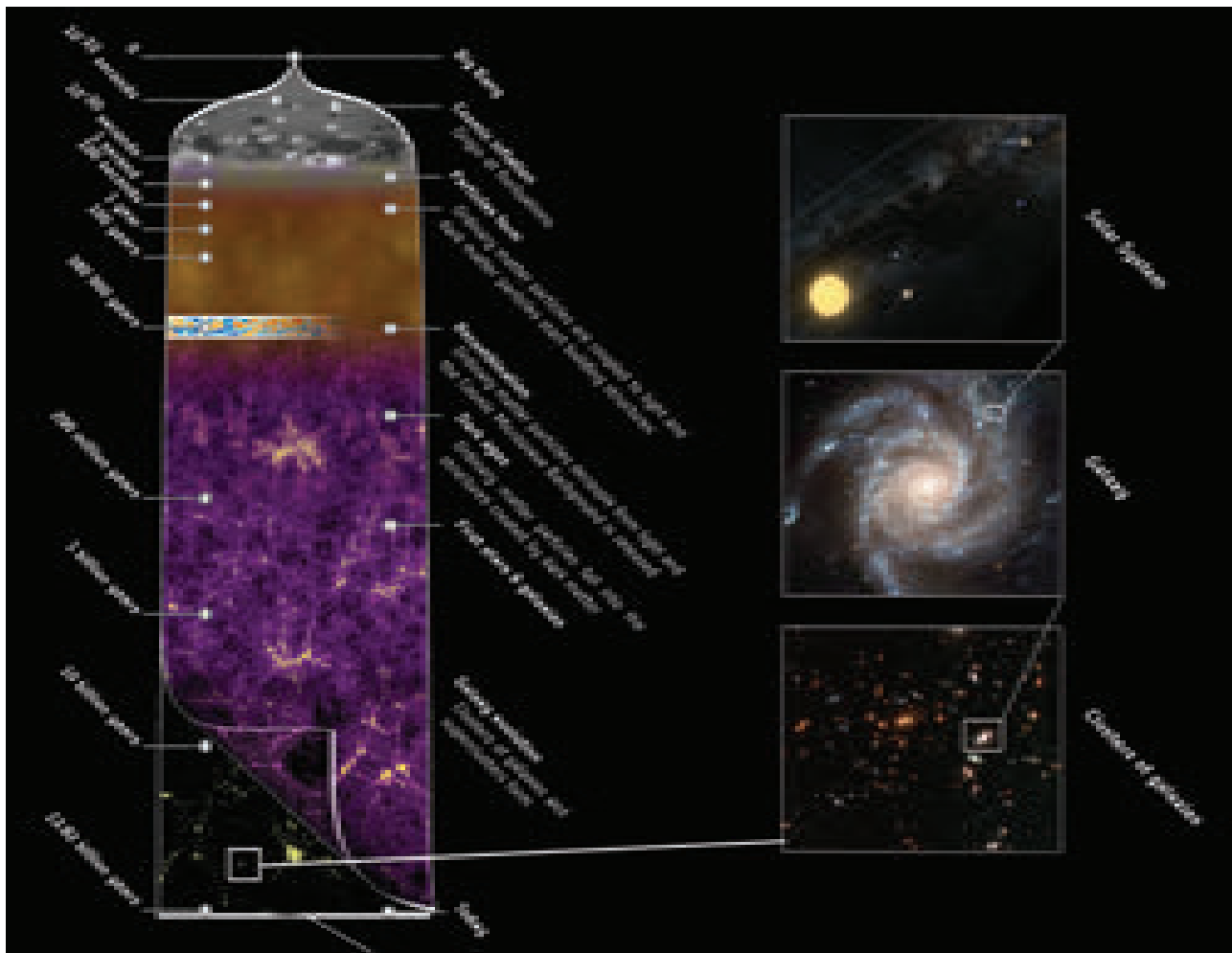
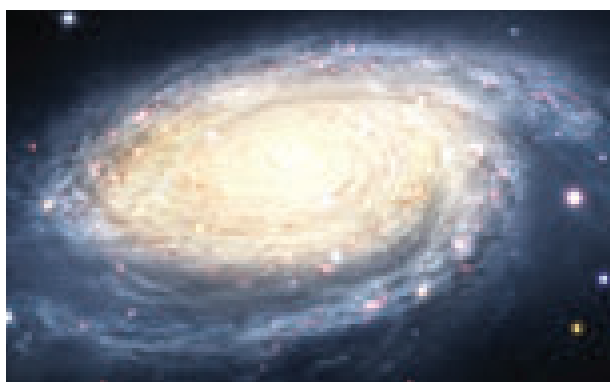

Figure 9.1 Formation of the universe

It is called Milky Way because it appears as a milky band of light in the sky. It is made up of approximately 100 billion stars and its diameter is 1,00,000 light years. Our solar system is 25,000 light years away from the centre of our galaxy. Just as the Earth goes around the Sun, the Sun goes around the centre of the galaxy and it takes 250 million years to do that.



**Figure 9.2** Milky Way Galaxy



The distance of Andromeda, our nearest galaxy is approximately 2.5 million light-years. If we move at the speed of the Earth (30 km/s), it would take us 25 billion years to reach it!

### 9.1.3 Stars

Stars are the fundamental building blocks of galaxies. Stars were formed when the galaxies were formed during the Big Bang. Stars produce heat, light, ultraviolet rays, x-rays, and other forms of radiation. They are largely composed of gas and plasma (a superheated state of matter). Stars are built by hydrogen gases. Hydrogen atoms fuse together to form helium atoms and in the process they produce large amount of heat. In a dark night we can see nearly 3,000 stars with the naked eye. We don't know how many stars exist. Our universe contains more than 100 billion galaxies, and each of those galaxies may have more than 100 billion stars.

Though the stars appear to be alone, most of the stars exist as pairs. The brightness of a star depends on their intensity and the distance from the Earth. Stars also appear to

be in different colours depending on their temperature. Hot stars are white or blue, whereas cooler stars are orange or red in colour. They also occur in many sizes.

A group of stars forms an imaginary outline or meaningful pattern on the space. They represent an animal, mythological person or creature, a god, or an object. This group of stars is called constellations. People in different cultures and countries adopted their own sets of constellation outlines. There are 88 formally accepted constellations. Aries, Gemini, Leo, Orion, Scorpius and Cassiopeia are some of the constellations.

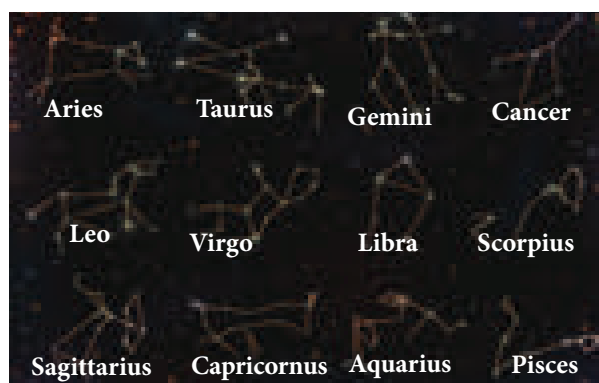

**Figure 9.3** Constellations

### Activity 2

Observe the sky keenly during night. Can you see group of stars? Can you figure out any shape? Discuss with your teachers and find out their name.

## 9.2 The Solar System

Sun and the celestial bodies which revolve around it form the solar system. It consists of large number of bodies such as planets, comets, asteroids and meteors. The gravitational force of attraction between the Sun and these objects keep them revolving around it.

### 9.2.1 The Sun

The Sun is a medium sized star, a very fiery spinning ball of hot gases. Three quarters of the

Sun has hydrogen gas and one quarter has helium gas. It is over a million times as big as the Earth. Hydrogen atoms combine or fuse together to form helium under enormous pressure. This process, called nuclear fusion releases enormous amount of energy as light and heat. It is this energy which makes Sun shine and provide heat. Sun is situated at the centre of the solar system. The strong gravitational fields cause other solar matter, mainly planets, asteroids, comets, meteoroids and other debris, to orbit around it. Sun is believed to be more than 4.6 billion years old.

### Formation of the Sun

At the time of the Big Bang, hydrogen gas condensed to form huge clouds, which later concentrated and formed the numerous galaxies. Some of the hydrogen gas was left free and started floating around in our galaxy. With time, due to some changes, this free-floating hydrogen gas concentrated and paved way for the formation of the Sun and solar system. Gradually, the Sun and the solar system turned into a slowly spinning molecular cloud, composed of hydrogen and helium along with dust. The cloud started to undergo the process of compression, as a result of its own gravity. Its excessive and high-speed spinning ultimately resulted in its flattening into a giant disc.

### 9.2.2 Planets

A planet revolves around the Sun along a definite curved path which is called an orbit. It is elliptical. The time taken by a planet to complete one revolution is called its period of revolution.

Besides revolving around the Sun, a planet also rotates on its own axis like a top. The time taken by a planet to complete one rotation is called its period of rotation. The period of rotation of the Earth is 23 hours and 56 minutes and so the length of a day on Earth is taken as 24 hours. Table 9.1 tells about the length of a day on each planet.

The planets are spaced unevenly. The first four planets are relatively close together and close to the Sun. They form the inner solar

**Table 9.1** Length of a day on each planet

Planets	Length of a day
Mercury	58.65 days
Venus	243 days
Earth	23.93 hours
Mars	24.62 hours
Jupiter	9.92 hours
Saturn	10.23 hours
Uranus	17 hours
Neptune	18 hours

system. Farther from the Sun is the outer solar system, where the planets are much more spread out. Thus the distance between Saturn and Uranus is much greater (about 20 times) than the distance between the Earth and the Mars.

The four planets grouped together in the inner solar system are Mercury, Venus, Earth and Mars. They are called inner planets. They have a surface of solid rock crust and so are called terrestrial or rocky planets. Their insides, surfaces and atmospheres are formed in a similar way and form similar pattern. Our planet, Earth can be taken as a model of the other three planets.

The four large planets Jupiter, Saturn, Uranus and Neptune spread out in the outer solar system and slowly orbit the Sun are called outer planets. They are made of hydrogen, helium and other gases in huge amounts and have very dense atmosphere. They are known as gas giants and are called gaseous planets. The four outer planets Jupiter, Saturn, Uranus and Neptune have rings whereas the four inner planets do not have any rings. The rings are actually tiny pieces of rock covered with ice. Now let us learn about each planet in the solar system.

**Mercury:** Mercury is a rocky planet nearest to the Sun. It is very hot during day but very cold at night. Mercury can be easily observed through telescope than naked eye since it is very faint and small. It always appears in the eastern horizon or western horizon of the sky.



**Venus:** Venus is a special planet from the Sun, almost the same size as the Earth. It is the hottest planet in our solar system. After our moon, it is the brightest heavenly body in our night sky. This planet spins in the opposite direction to all other planets. So, unlike Earth, the Sun rises in the west and sets in the east here. Venus can be seen clearly through naked eye. It always appears in the horizon of eastern or western sky.

### Activity 3

Watch the sky in the early morning. Do you see any planet? What is its name? Find out with the help of your teacher.

**The Earth:** The Earth where we live is the only planet in the solar system which supports life. Due to its right distance from the Sun it has the right temperature, the presence of water and suitable atmosphere and a blanket of ozone. All these have made continuation of life possible on the Earth. From space, the Earth appears bluish green due to the reflection of light from water and land mass on its surface.

**Mars:** The first planet outside the orbit of the Earth is Mars. It appears slightly reddish and therefore it is also called the red planet. It has two small natural satellites (Deimos and Phobos).

**Jupiter:** Jupiter is called as Giant planet. It is the largest of all planets (about 11 times larger and 318 times heavier than Earth). It has 3 rings and 65 moons. Its moon Ganymede is the largest moon of our solar system.

**Saturn:** Known for its bright shiny rings, Saturn appears yellowish in colour. It is the second biggest and a giant gas planet in the outer solar system. At least 60 moons are present - the largest being Titan. Titan is the only moon in the solar system with clouds. Having least density of all (30 times less than Earth), this planet is so light.

**Uranus:** Uranus is a cold gas giant and it can be seen only with the help of large telescope. It has a greatly tilted axis of rotation. As a result,

in its orbital motion it appears to roll on its side. Due to its peculiar tilt, it has the longest summers and winters each lasting 42 years.

**Neptune:** It appears as Greenish star. It is the eighth planet from the Sun and is the windiest planet. Every 248 years, Pluto crosses its orbit. This situation continues for 20 years. It has 13 moons – Triton being the largest. Triton is the only moon in the solar system that moves in the opposite direction to the direction in which its planet spins.

## 9.2.3 Other Bodies of the Solar System

Besides the eight planets, there are some other bodies which revolve around the Sun. They are also members of the solar system.

### Asteroids

There is a large gap in between the orbits of Mars and Jupiter. This gap is occupied by a broad belt containing about half a million pieces of rocks that were left over when the planets were formed and now revolve around the Sun. These are called asteroids. The biggest asteroid is Ceres – 946 km across. Every 50 million years, the Earth is hit by an asteroid nearing 10 km across. Asteroids can only be seen through large telescope.

### Comets

Comets are lumps of dust and ice that revolve around the Sun in highly elliptical orbits. Their period of revolution is very long. When approaching the Sun, a comet vaporizes and forms a head and tail. Some of the biggest comets ever seen had tails 160 million (16 crores) km long. This is more than the distance between the Earth and the Sun. Many comets are known to appear periodically. One such comet is Halley's Comet, which appears after nearly every 76 years. It was last seen in 1986. It will next be seen in 2062.

### Meteors and Meteorites

Meteors are small piece of rocks scattered throughout the solar system. Traveling with high speed, these small pieces come closer to

the Earth's atmosphere and are attracted by the gravitational force of Earth. Most of them are burnt up by the heat generated due to friction in the Earth's atmosphere. They are called meteors. Some of the bigger meteors may not be burnt completely and they fall on the surface of Earth. These are called meteorites.



**Figure 9.4** Meteors and Meteorites

### Satellites

A body moving in an orbit around a planet is called satellite. In order to distinguish them from the man made satellites (called as artificial satellites), they are called as natural satellites or moons. Satellite of the Earth is called Moon (other satellites are written as moon). We can see the Earth's satellite Moon, because it reflects the light of the Sun. Satellite moves around the planets due to gravity, and the centripetal force. Among the planets in the solar system all the planets have moons except Mercury and Venus.



**DO YOU KNOW?** The Sun travelling at a speed of 250 km per second (9 lakh km/h) takes about 225 million years to complete one revolution around the Milky Way. This period is called a cosmic year.

## 9.3 Orbital Velocity

We saw that there are natural satellites moving around the planets. There will be gravitational force between the planet and satellites. Nowadays

many artificial satellites are launched into the Earth's orbit. The first artificial satellite Sputnik was launched in 1956. India launched its first satellite Aryabhata on April 19, 1975. Artificial satellites are made to revolve in an orbit at a height of few hundred kilometres. At this altitude, the friction due to air is negligible. The satellite is carried by a rocket to the desired height and released horizontally with a high velocity, so that it remains moving in a nearly circular orbit.

The horizontal velocity that has to be imparted to a satellite at the determined height so that it makes a circular orbit around the planet is called orbital velocity.

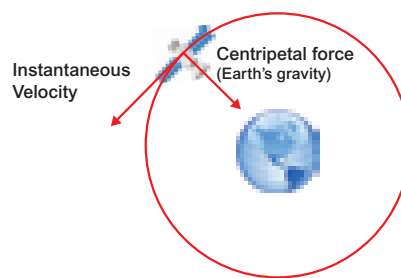

**Figure 9.5** Orbital velocity

The orbital velocity of the satellite depends on its altitude above Earth. Nearer the object to the Earth, the faster is the required orbital velocity. At an altitude of 200 kilometres, the required orbital velocity is little more than 27,400 kph. That orbital speed and distance permit the satellite to make one revolution in 24 hours. Since Earth also rotates once in 24 hours, a satellite stays in a fixed position relative to a point on Earth's surface. Because the satellite stays over the same spot all the time, this kind of orbit is called 'geostationary'. Orbital velocity can be calculated using the following formula.

$$v = \sqrt{\frac{GM}{R+h}} \text{ where,}$$

G = Gravitational constant ( $6.673 \times 10^{-11} \text{ Nm}^2\text{kg}^{-2}$ )

M = Mass of the Earth ( $5.972 \times 10^{24} \text{ kg}$ )

R = Radius of the Earth (6371 km)

h = Height of the satellite from the surface of the Earth.



### Problem 1

Can you calculate the orbital velocity of a satellite orbiting at an altitude of 500 km?

Data:  $G = 6.673 \times 10^{-11}$  SI units;

$M = 5.972 \times 10^{24}$  kg;  $R = 6371000$  m;

$h = 500000$  m.

**Solution:**

$$v = \sqrt{\frac{6.67 \times 10^{-11} \times 5.972 \times 10^{24}}{(6371000 + 500000)}}$$

Ans:  $v = 7613 \text{ ms}^{-1}$  or  $7.613 \text{ kms}^{-1}$



Microgravity is the condition in which people or objects appear to be weightless. The effects of microgravity can be seen when astronauts and objects float in space. Micro- means very small, so microgravity refers to the condition where gravity 'seems' to be very small.

## 9.4 Time period of a Satellite

*Time taken by a satellite to complete one revolution round the Earth is called time period.*

$$\text{Time period, } T = \frac{\text{Distance covered}}{\text{Orbital velocity}}$$

$$T = \frac{2\pi r}{v}$$

Substituting the value of  $v$ , we get

$$T = \frac{2\pi(R + h)}{\sqrt{\frac{GM}{(R + h)}}}$$

### Problem 2

At an orbital height of 500 km, find the orbital period of the satellite.

**Solution:**

$h = 500 \times 10^3 \text{ m}$ ,  $R = 6371 \times 10^3 \text{ m}$ ,

$v = 7616 \times 10^3 \text{ kms}^{-1}$ .

$$T = \frac{2\pi(R + h)}{v} = 2 \times \frac{22}{7} \times \frac{(6371 + 500)}{7616}$$
$$= 5.6677 \times 10^3 \text{ s} = 5667 \text{ s}.$$

This is  $T \approx 95 \text{ min}$



All stars appear to us as moving from east to west, where as there is one star which appears to us stationary in its position. It has been named as Pole star. The pole star appears to us as fixed in space at the same place in the sky in the north direction because it lies on the axis of rotation of the Earth which itself is fixed and does not change its position in space. It may be noted that the pole star is not visible from the southern hemisphere.

### Activity 4

Prepare a list of Indian satellites from Aryabhata to the latest along with their purposes.

## 9.5 Kepler's Laws

In the early 1600s, Johannes Kepler proposed three laws of planetary motion. Kepler was able to summarize the carefully collected data of his mentor, Tycho Brahe with three statements that described the motion of planets in a Sun-centered solar system. Kepler's efforts to explain the underlying reasons for such motions are no longer accepted; nonetheless, the actual laws themselves are still considered an accurate description of the motion of any planet and any satellite. Kepler's three laws of planetary motion can be described as below.

### First Law – The Law of Ellipses

*All planets revolve around the Sun in elliptical orbits with Sun at one of their foci.*

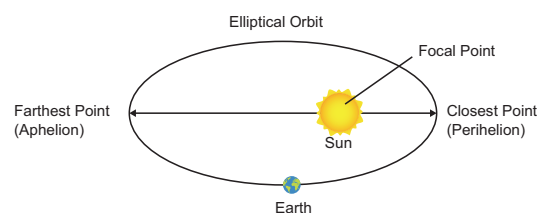
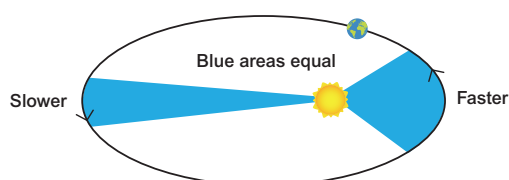

Figure 9.6 The Law of Ellipses



## Second Law – The Law of Equal Areas

*The line connecting the planet and the Sun covers equal areas in equal intervals of time.*



**Figure 9.7** The Law of Equal Area

## Third Law – The Law of Harmonies

*The square of time period of revolution of a planet around the Sun is directly proportional to the cube of the distance between sun and the planets.*

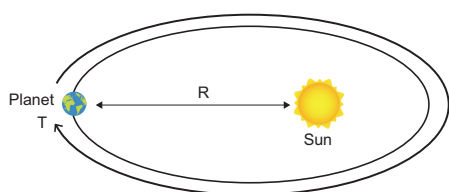

**Figure 9.8** The Law of Harmonics

## 9.6 International Space Station

ISS is a large spacecraft which can house astronauts. It goes around in low Earth orbit at approximately 400 km distance. It is also a science laboratory. Its very first part was placed in orbit in 1998 and its core construction was completed by 2011. It is the largest man-made object in space which can also be seen from the Earth through the naked eye. The first human crew went to the ISS in 2000. Ever since that, it has never been unoccupied by humans. At any given instant, at least six humans will be present

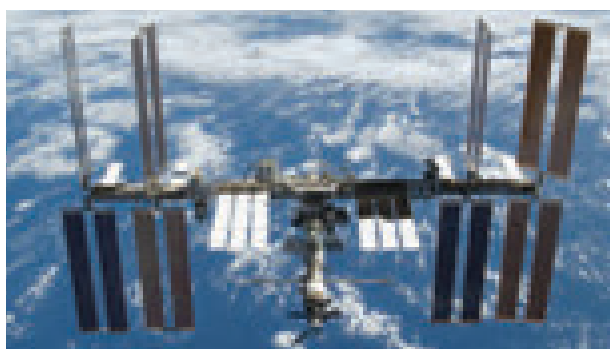

**Figure 9.9** International Space Station

in the ISS. According to the current plan, ISS will be operated until 2024, with a possible extension until 2028. After that, it could be deorbited, or recycled for future space stations.

### 9.6.1 Benefits of ISS

According to NASA, the following are some of the ways in which the ISS is already benefitting us or will benefit us in the future.

#### Supporting water-purification efforts

Using the technology developed for the ISS, areas having water scarcity can gain access to advanced water filtration and purification systems. The water recovery system (WRS) and the oxygen generation system (OGS) developed for the ISS have already saved a village in Iraq from being deserted due to lack of clean water.

#### Eye tracking technology

The Eye Tracking Device, built for a microgravity experiment, has proved ideal to be used in many laser surgeries. Also, eye tracking technology is helping disabled people with limited movement and speech. For example, a kid who has severe disability in body movements can use his eye-movements alone and do routine tasks and lead an independent life.

#### Robotic arms and surgeries

Robotic arms developed for research in the ISS are providing significant help to the surgeons in removing inoperable tumours (e.g., brain tumours) and taking biopsies with great accuracies. Its inventors say that the robot could take biopsies with remarkable precision and consistency.

Apart from the above-mentioned applications, there are many other ways in which the researches that take place in the ISS are helpful. They are: development of improved vaccines, breast cancer detection and treatment, ultrasound machines for remote regions etc.,

## 9.6.2 ISS and International Cooperation

As great as the ISS' scientific achievements are, no less in accomplishment is the international co-operation which resulted in the construction of the ISS. An international collaboration of five different space agencies of 16 countries provides, maintains and operates the ISS. They are: NASA (USA), Roskosmos (Russia), ESA (Europe), JAXA (Japan) and CSA (Canada). Belgium, Brazil, Denmark, France, Germany, Italy, Holland, Norway, Spain, Sweden, Switzerland and the UK are also part of the consortium.

### Points to Remember

- ❖ The basic constituent of universe is galaxies which are really the collection of billions of stars.
- ❖ Scientists think that the universe began with the start of a massive explosion called the Big Bang.
- ❖ Depending on their appearance, galaxies are classified as spiral, elliptical, or irregular.
- ❖ Our Sun and all the planets in the solar system are in the Milky Way galaxy.
- ❖ A group of stars forms an imaginary outline or meaningful pattern on the space, called constellations.
- ❖ The Sun and celestial bodies which revolve around it form the solar system.
- ❖ Due to its right distance from the Sun, Earth has the right temperature, the presence of water and suitable atmosphere and a blanket of ozone.
- ❖ Millions of pieces of rocks that were left over when the planets were formed and now revolve around the Sun are called asteroids.
- ❖ A body moving in an orbit around a planet is called satellite.
- ❖ The ISS is intended to act as a scientific laboratory and observatory. Its main purpose is to provide an international lab for conducting experiments in space.

## A-Z GLOSSARY

<b>Asteroid</b>	Small, rocky object orbiting the Sun.
<b>Comet</b>	A chunk of dirty, dark ice, mixed with dust which revolves around the Sun.
<b>Constellation</b>	A group of stars that can be seen as a pattern from Earth.
<b>Galaxy</b>	A group of stars, nebulae, star clusters, globular clusters and other matter.
<b>Meteor</b>	A meteoroid that travels through the Earth's atmosphere.
<b>Meteorite</b>	A meteor that hits the Earth's surface.
<b>Milky Way</b>	A broad band of light that looks like a trail of spilled milk in the night sky.
<b>Moon</b>	Any natural object which orbits a planet.
<b>Planet</b>	A relatively large object that revolves around a star, but which is not itself a star.
<b>Satellite</b>	Any object in outer space that orbits another object.
<b>Space station</b>	A large, manned satellite in space used as a base for space exploration.
<b>Star</b>	A ball of constantly exploding gases, giving off light and heat.
<b>Universe</b>	Everything in space, including the galaxies and stars, the Milky Way and the Solar System.



## TEXTBOOK EXERCISES



### I. Choose the correct answer.

- Who proposed the heliocentric model of the universe?  
(a) Tycho Brahe (b) Nicolaus Copernicus  
(c) Ptolemy (d) Archimedes
- Which of the following is not a part of outer solar system?  
(a) Mercury (b) Saturn  
(c) Uranus (d) Neptune
- Ceres is a \_\_\_\_\_.  
(a) Meteor (b) Star  
(c) Planet (d) Astroid
- The period of revolution of planet A around the Sun is 8 times that of planet B. How many times is the distance of planet A as great as that of planet B?  
(a) 4 (b) 5 (c) 2 (d) 3
- The Big Bang occurred \_\_\_\_\_ years ago.  
(a) 13.7 billion (b) 15 million  
(c) 15 billion (d) 20 million

### II. Fill in the blanks.

- The speed of Sun in km/s is \_\_\_\_\_.
- The rotational period of the Sun near its poles is \_\_\_\_\_.
- India's first satellite is \_\_\_\_\_.
- The third law of Kepler is also known as the Law of \_\_\_\_\_.
- The number of planets in our Solar System is \_\_\_\_\_.

### III. State whether true or false. If false, correct the statement.

- ISS is a proof for international cooperation.
- Halley's comet appears after nearly 67 hours.
- Satellites nearer to the Earth should have lesser orbital velocity.
- Mars is called the red planet.

### IV. Answer briefly.

- What is solar system?
- Define orbital velocity.
- Define time period of a satellite.
- What is a satellite? What are the two types of satellites?
- Write a note on the inner planets.
- Write about comets.
- State Kepler's laws.
- What factors have made life on Earth possible?

### V. Answer in detail.

- Give an account of all the planets in the solar system.
- Discuss the benefits of ISS.
- Write a note on orbital velocity.

### VI. Conceptual questions.

- Why do some stars appear blue and some red?
- How is a satellite maintained in nearly circular orbit?
- Why are some satellites called geostationary?
- A man weighing 60 kg in the Earth will weigh 1680 kg in the Sun. Why?

### VII. Numerical problems.

- Calculate the speed with which a satellite moves if it is at a height of 36,000 km from the Earth's surface and has an orbital period of 24 hr (Take  $R = 6370$  km)  
[Hint: Convert hr into seconds before doing calculation]
- At an orbital height of 400 km, find the orbital period of the satellite.



## REFERENCE BOOKS

1. Big Bang - By Simon Singh.
2. What are the stars? - By G. Srinivas.
3. An introduction to Astronomy - By Baidyanath Basu.



## INTERNET RESOURCES

- <https://www.space.com/52-the-expanding-universe-from-the-big-bang-to-today.html>  
<https://phys.org/news/2016-06-star-black-hole.html>



## ICT CORNER

### Building Blocks of Universe

#### Steps

- Type the given URL to reach interactive universe and allow the browser to play “JAVA Script”, if asked.
- Click and drag the “Scale Pointer” present in the right side of the page or scroll the mouse to zoom into the universe.
- Click and drag the mouse pointer to North-South (up-down) axis to observe the fabricating structure of the galaxy.
- Zoom in on to extreme close up to view the solar system and to view the name of the objects present in the galaxy.

#### Interactive Universe’s

URL: <http://stars.chromeexperiments.com/> or Scan the QR Code.





### Learning Objectives

After completing this lesson, students will be able to

- classify substances as elements, compounds and mixtures based on their chemical composition.
- group mixtures as homogeneous and heterogeneous.
- identify suitable method to separate components of a mixture.
- classify solutions based on the size of the solute particles and compare the true solutions, colloids and suspensions based on their properties.
- differentiate colloids based on the nature of dispersed phase and dispersion medium.
- compare o/w and w/o emulsions.
- discuss some important examples and uses of colloids.

### Introduction

We use the term **matter** to cover all substances and materials from which the universe is composed. Matter is everything around us. The air we breathe, the food we eat, the pen we write, clouds, stones, plants, animals, a drop of water or a grain of sand everything is matter. Samples of any of these materials have two properties in common. They have mass and they occupy space.



**Figure 10.1** Examples to show Matter has mass



**Figure 10.2** Examples to show Matter occupies space

Thus, we say that **matter** is anything that has mass and occupies space.

### 10.1 Classification of Matter

In class VIII, You have studied the classification of matter on the basis of their physical states. Now let us see how we can classify matter on the basis of chemical composition. Broadly speaking, it has been classified into pure substances and mixtures. From the point of view of chemistry, pure substances are those which contain only one kind of particles whereas impure substances (mixtures) contain more than one kind of particles.

The flow chart given below will help us to understand the chemical classification of matter in detail.



**DO YOU KNOW?**

Not all things that we see or feel are matter. For example, sunlight, sound, force and energy neither occupy space nor have any mass. They are not matter.

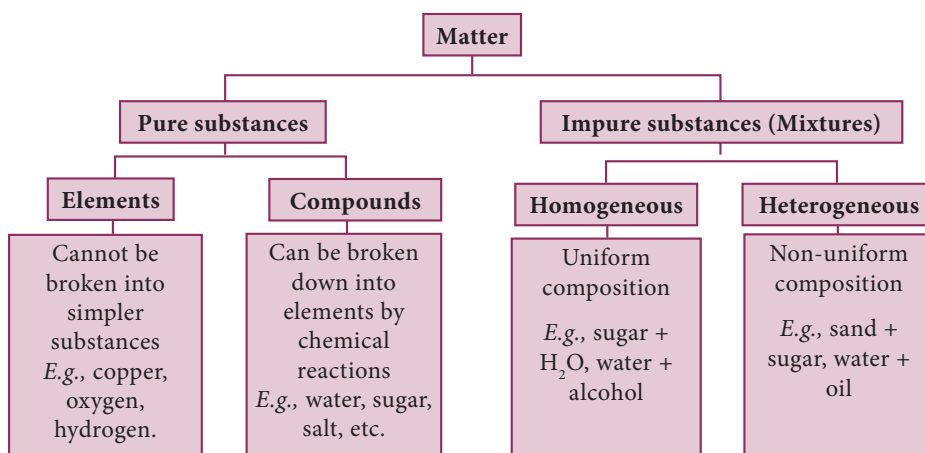

### Activity 1

1. Is air a pure substance or Mixture? Justify
2. You must have seen brass statues in museums and places of worship. Brass is an alloy made up of approx. 30% zinc and 70% copper. Is Brass a pure substance or a mixture or compound?

H, He, Li..... 118 elements

Building block of all materials

Robert Boyle used the name element for any substance that cannot be broken down further, into a simpler substance. This definition can be extended to include the fact that each element is made up of only one kind of atom. For example, aluminium is an element which is made up of only aluminium atoms. It is not possible to obtain a simpler substance chemically from the aluminium atoms. You can only make more complicated substances from it, such as aluminium oxide, aluminium nitrate and aluminium sulphate.

### 10.1.1 Elements

Most of you may be interested in music, and some of you may know how it is composed. Music is the combination of a few basic musical notes i.e., Sa, Re, Ga, ... Thus, the building blocks of music are the musical notes.

Sa, Re, Ga, Ma, Pa...

Building blocks of music

Likewise, all substances on earth are made up of certain simple substances called elements. Plants, cats, apples, rocks, cars and even our bodies contain elements. Thus, elements are the building block of all materials.



In the modern periodic table there are 118 elements known to us, 92 of which are naturally occurring while the remaining 26 have been artificially created. But from these 118 elements, crores of compounds are formed—some naturally occurring and some artificial. Isn't that amazing?

**Atom:** The smallest unit of an element which may or may not have an independent existence, but always takes part in a chemical reaction is called atom.

**Molecules:** The smallest unit of a pure substance, which always exists independently and can retain physical and chemical properties of that substance is called a molecule.

#### Examples:

Hydrogen molecule consists of two hydrogen atoms (H<sub>2</sub>)

Water molecule consists of two hydrogen atoms (H<sub>2</sub>) and one oxygen atom (O).

All elements can be classified according to various properties. A simple way to do this is to classify them as metals, non metals and metalloids.

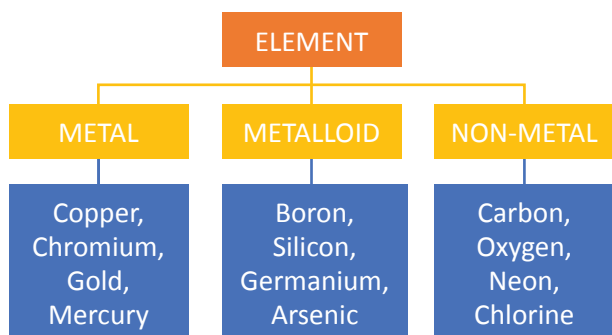

### 10.1.2 Compounds

When two or more elements combine chemically to form a new substance, the new substance is called a compound. For example, cane sugar is made up of three elements carbon, hydrogen and oxygen. The chemical formula of cane sugar is  $C_{12}H_{22}O_{11}$ .

A compound has properties that are different from those of the elements from which it is made. Common salt, also known as sodium chloride, is a compound. It is added to give taste to our food. It is a compound made up of a metal, sodium and a non-metal, chlorine.

#### Activity 2

Make models of the molecules of compounds by using match sticks and clay balls as shown below,

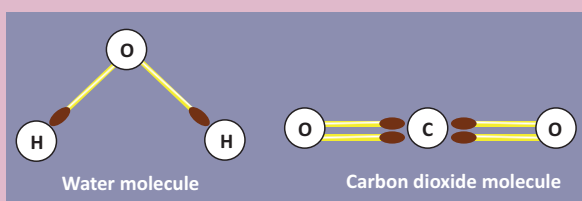

Compounds of phosphorous, nitrogen and potassium are used in fertilizers. Silicon compounds are of immense importance in the computer industry. Compounds of fluorine are used in our toothpastes as they strengthen our teeth.

**Table 10.1** Difference between elements and compounds.

Element	Compound
Made up of only one kind of atom.	Made up of more than one kind of atom.
The smallest particle that retains all its properties is an atom.	The smallest particle that retains all its properties is the molecule.
Cannot be broken down into simpler substances.	Can be broken down into elements by chemical methods.

### 10.1.3 Mixtures

A mixture is an impure substance. It contains *two or more kinds of elements or compounds or both physically mixed together in any ratio*. For example, tap water is a mixture of water and some dissolved salts. Lemonade is a mixture of lemon juice, sugar and water. Air is a mixture of nitrogen, oxygen, carbon dioxide, water vapour and other gases. Soil is a mixture of clay, sand and various salts. Milk, ice cream, rock salt, tea, smoke, wood, sea water, blood, tooth paste and paint are some other examples of mixtures. Alloys are mixtures of metals.



**Figure 10.3** Mixtures

#### More to Know

##### LPG – Liquefied Petroleum Gas

It is highly inflammable hydrocarbon gas. It contains mixture of butane and propane gases. LPG, liquefied through pressurisation, is used for heating, cooking, auto fuel etc.



### 10.1.4 Differences Between Compound and Mixture

There are differences between compounds and mixtures. This can be shown by the following activity.

### Activity 3

Take some powdered iron filings and mix it with sulphur.

- Divide the mixture into two equal halves.
- Keep the first half of the mixture as it is, but heat the second half of the mixture.
- On heating you will get a black brittle compound.

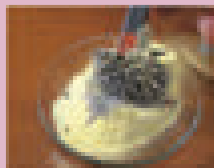

Mixture of iron and Sulphur



Iron Sulphide compound

The black compound is Iron (II) sulphide.

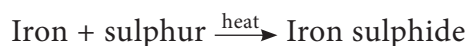

The Iron sulphide formed has totally different properties to the mixture of iron and sulphur as tabulated below:

Substance	Appearance	Effect of magnet
Iron (element)	Dark grey powder	Attracted to it
Sulphur (element)	Yellow powder	None
Iron + Sulphur (Mixture)	Dirty yellow powder	Iron powder attracted to it
Iron sulphide (compound)	Black solid	No effect

From the above experiment, we can summarise the major differences between mixtures and compounds:



Blood is not a pure substance. It is a mixture of various components such as platelets, red and white blood corpuscles and plasma.

**Table 10.2** Difference between mixtures and compounds.

Mixture	Compound
It contains two or more substances	It is a single substance
The constituent may be present in any proportion.	The constituents are present in definite proportions.
They show the properties of their constituents.	They do not show the properties of the constituent elements.
The components may be separated easily by physical methods.	The constituents can only be separated by one or more chemical reactions.

### Activity 4

Identify whether the given substance is mixture or compound and justify your answer. 1. Sand and water 2. Sand and iron filings 3. Concrete 4. Water and oil 5. Salad 6. Water 7. Carbon dioxide 8. Cement 9. Alcohol.

## 10.2 Types of Mixtures

Most of the substances that we use in our daily life are mixtures. In some we will be able to see the components with our naked eyes but in most others the different components are not visible. Based on this mixture can be classified as below.

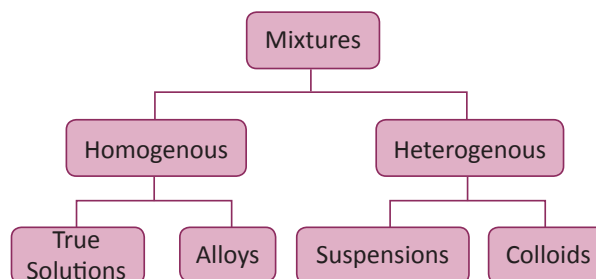

### 10.2.1 Homogeneous and Heterogeneous mixture

A mixture in which the components cannot be seen separately is called a homogeneous mixture.



It has a uniform composition and every part of the mixture has the same properties. Tap water, milk, air, ice cream, sugar syrup, ink, steel, bronze and salt solution (Figure 10.4a) are homogeneous mixtures.

A mixture in which the components can be seen separately is called a heterogeneous mixture. It does not have a uniform composition and properties. Soil, a mixture of iodine and common salt, a mixture of sugar and sand, a mixture of oil and water, a mixture of sulphur and iron filings and a mixture of milk and cereals (Figure 10.4b) are heterogeneous mixtures.



**Figure 10.4** (a) Homogeneous and (b) Heterogeneous mixture

### 10.3 Separation of mixtures

Many mixtures contain useful substances mixed with unwanted material. In order to obtain these useful substances, chemists often have to separate them from the impurities. The choice of a particular method to separate components of a mixture will depend on the properties of the components of the mixture as well as their physical states (as shown in Table 10.3).

#### 10.3.1 Sublimation

Certain solid substances when heated change directly from solid to gaseous state without attaining liquid state. The vapours

when cooled give back the solid substance. This process is known as sublimation. Examples: Iodine, camphor, ammonium chloride etc.,

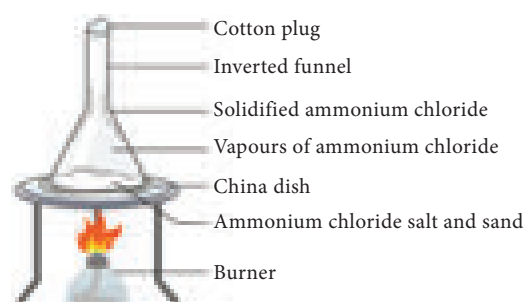

**Figure 10.5** Sublimation

The powdered mixture of Ammonium chloride and sand is taken in a china dish and covered with a perforated asbestos sheet. An inverted funnel is placed over the asbestos sheet as shown in Figure 10.5. The open end of the stem of the funnel is closed using cotton wool and the china dish is heated. The pure vapours of the volatile solid pass through the holes in the asbestos sheet and condense on the inner sides of the funnel. The non-volatile impurities remain in the china dish.

#### More to Know

The air fresheners are used in toilets. The solid slowly sublimates and releases the pleasant smell in the toilet over a certain period of time. Moth balls, made of naphthalene are used to drive away moths and some other insects. These also sublime over time. Camphor, is a substance used in Indian household. It sublimates to give a pleasant smell and is sometimes used as a freshener.

**Table 10.3** Methods of separating substances from mixtures

Type of mixtures	Mixtures	Methods of separation
Heterogeneous	Solid and solid	Handpicking, sieving, winnowing, magnetic separation, <b>sublimation</b> .
	Insoluble solid and liquid	Sedimentation and decantation, loading, filtration, <b>centrifugation</b>
	Two immiscible liquids	Decantation, <b>solvent extraction</b>
Homogeneous	Soluble solid and liquid	Evaporation, <b>distillation</b> , crystallisation
	Two miscible liquids	<b>Fractional distillation</b>
	Solution of two or more solids in a liquid	<b>Chromatography</b>

### 10.3.2 Centrifugation

Centrifugation is the process by which fine insoluble solids from a solid-liquid mixture can be separated in a machine called a centrifuge. A centrifuge rotates at a very high speed. On being rotated by centrifugal force, the heavier solid particles move down and the lighter liquid remains at the top.



Figure 10.6 Centrifugation

In milk dairies, centrifugation is used to separate cream from milk. In washing machines, this principle is used to squeeze out water from wet clothes. Centrifugation is also used in pathological laboratories to separate blood cells from a blood sample.

### 10.3.3 Solvent extraction

Two immiscible liquids can be separated by solvent extraction method. This method works on the principle of difference in solubility of two immiscible liquids in a suitable solvent. For example, mixture of water and oil can be separated using a separating funnel. Solvent extraction method is used in pharmaceutical and petroleum industries.

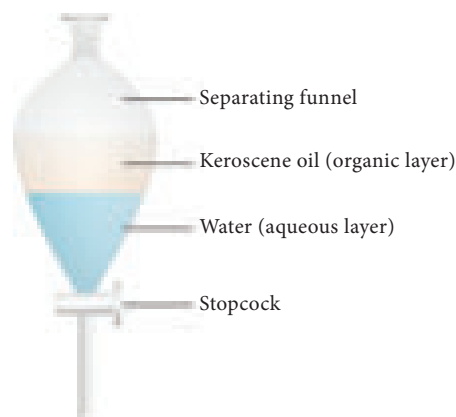

Figure 10.7 Solvent extraction

**DO YOU KNOW?**

Solvent extraction is an old practice done for years. It is the main process in perfume development and it is also used to obtain dyes from various sources.

### 10.3.4 Simple distillation

Distillation is a process of obtaining pure liquid from a solution. It is actually a combination of evaporation and condensation i.e

**Distillation = Evaporation + Condensation**

In this method, a solution is heated in order to vapourise the liquid. The vapours of the liquid on cooling, condense into pure liquid. For example, sea water in many countries is converted into drinking water by distillation. This method is also used to separate two liquids whose boiling points differ more than 25 K.

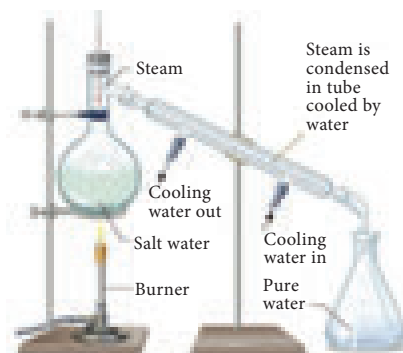

Figure 10.8 Solvent extraction

A distillation flask is fixed with a water condenser. A thermometer is introduced into the distillation flask through an one-holed stopper. The bulb of the thermometer should be slightly below the side tube.

The brackish water (sea water) to be distilled is taken in the distillation flask and heated for boiling. The pure water vapour passes through the inner tube of the condenser. The vapours on cooling condense into pure water (distillate) and are collected in a receiver. The salt are left behind in the flask as a residue.

### 10.3.5 Fractional distillation

To separate two or more miscible liquids which do not differ much in their boiling

points (difference in boiling points is less than 25 K) fractional distillation is employed.

Fractional distillation is used in petrochemical industry to obtain different fractions of petroleum, to separate the different gases from air, to distill alcohols etc.

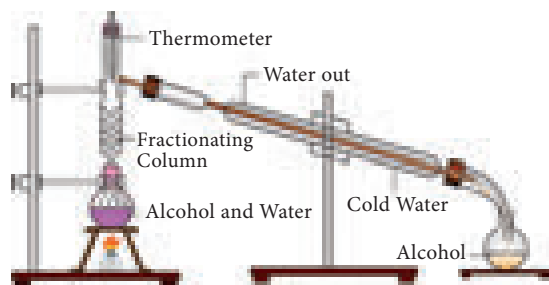

Figure 10.9 Fractional distillation

### 10.3.6 Chromatography

Before we discuss the technique we will take a look at the difference between the two important terms: **Absorption** and **Adsorption**

**Adsorption** is the process in which the particles of a substance is concentrated only at the surface of another substance.

**Absorption** is the process in which the substance is uniformly distributed throughout the bulk of another substance.

For example, when a chalk stick is dipped in ink, the surface retains the colour of the ink due to adsorption of coloured molecules while the solvent of the ink goes deeper into the stick due to absorption. Hence, on breaking the chalk stick, it is found to be white from inside.

Chromatography is also a separation technique. It is used to separate different components of a mixture based on their different solubilities in the same solvent. There are several types of chromatography

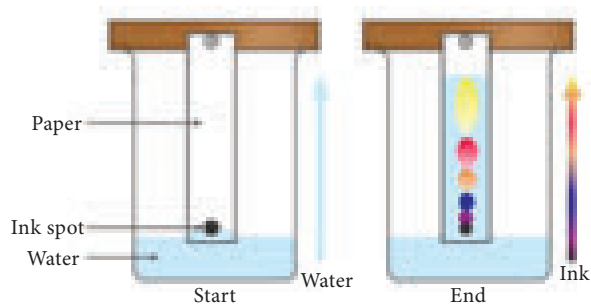

Figure 10.10 Paper chromatography

based on the above basic principles. The simplest type is paper chromatography.

### Paper chromatography

This method is used to separate the different coloured dyes in a sample of ink. A spot of the ink (e.g. black ink) is put on to a piece of chromatography paper. This paper is then set in a suitable solvent as shown in figure 10.10. The black ink separates into its constituent dyes. As the solvent moves up the paper, the dyes are carried with it and begin to separate. They separate because they have different solubility in the solvent and are adsorbed to different extents by the chromatography paper. The chromatogram shows that the black ink contains three dyes.

## 10.4 Solutions

A solution is a homogeneous mixture of two or more substances. In a solution, the component present in lesser amount by weight is called solute and the component present in larger amount by weight is called solvent.

In short, a solution can be represented as follows: solute + solvent  $\longrightarrow$  solution

Example: salt + water  $\longrightarrow$  salt solution

### 10.4.1 Types of solution

Based on the particle size of the solute, the solutions are divided into three types. Let us study them through an activity.

#### Activity 5

Take bottles containing sugar, starch and wheat flour. Add one tea spoon full of each one to a glass of water and stir well. Leave it aside for about ten minutes. What do you observe?



We can see that in the case of sugar we get a clear solution and the particles never settle down. This mixture is called as true solution. In the case of starch and water we get a cloudy mixture. This mixture is called as colloidal solution. In the case of wheat flour mixed with water we get a very turbid mixture and fine particles slowly settle down at the bottom after some time. This mixture is called as suspension.

What are the differences among True solutions, colloids and suspensions?

The major difference is the particle size of the solute. In fact interconversions of these mixtures are possible by varying the particle sizes by certain chemical and physical methods.

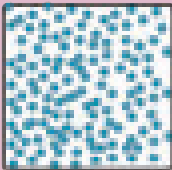
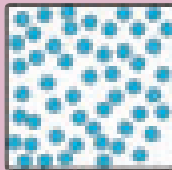
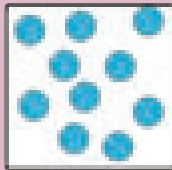
Particle size less than $10^{-7}$ cm	Particle size between $10^{-7}$ cm and $10^{-5}$ cm	Particle size greater than $10^{-5}$ cm
		
True solution	Colloidal solution	Suspension

### 10.4.2 Colloidal Solutions

A colloidal solution is a heterogeneous system consisting of the dispersed phase and the dispersion medium. Dispersed phase or the dispersion medium can be a solid, or liquid or gas. There are eight



different combinations possible (Table 10.4). The combination of gas in gas is not possible because gas in gas always forms a true solution.

### Brownian movement

When colloidal solution are viewed under powerful microscope, it can be seen that colloidal particles are moving constantly and rapidly in zig-zag directions. The Brownian movement of colloidal particles is due to the unbalanced bombardment of the particles by the molecules of dispersion medium.

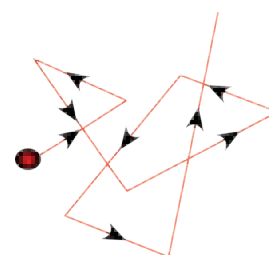

Figure 10.11 Brownian movement

### Tyndall effect

Tyndall (1869) observed that when a strong beam of light is focused on a colloidal solution the path of the beam becomes visible. This phenomenon is known as **Tyndall effect** and the illuminated path is called **Tyndall cone**. This phenomenon is not observed in case of true solution.

#### More to Know

The beam of light coming from headlights of vehicles is due to Tyndall effect. Blue colour of sky is also due to Tyndall effect.

Table 10.4 Classification of colloids based on physical state of dispersed phase and dispersion medium

S.No	Dispersed Phase (Solute)	Dispersion Medium (Solvent)	Name	Examples
1	Solid	Solid	Solid sol	Alloys, gems, coloured glass
2	Solid	Liquid	Sol	Paints, inks, egg white
3	Solid	Gas	Aerosol	Smoke, dust
4	Liquid	Solid	Gel	Curd, Cheese, jelly
5	Liquid	Liquid	Emulsion	Milk, butter, oil in water
6	Liquid	Gas	Aerosol	Mist, fog, clouds
7	Gas	Solid	Solid foam	Cake, bread
8	Gas	Liquid	Foam	Soap lather, Aerated water

### Differences between the types of solutions.

Property	Suspension	Colloidal sol.	Solution
Particle size	>100nm	1 to 100nm	<1nm
Filtration separation	Possible	Impossible	Impossible
Settling of particles	Settle on their own	Settle on centrifugation	Do not settle
Appearance	Opaque	Translucent (or) Semi transparent	Transparent
Scattering of light	Does not penetrate	Scatteres	Does not Scatter
Diffusion of particles	Do not diffuse	Diffuse slowly	Diffuse rapidly
Brownian movement	May show	Shows	Does not show
Nature	Heterogeneous	Heterogeneous	Homogeneous

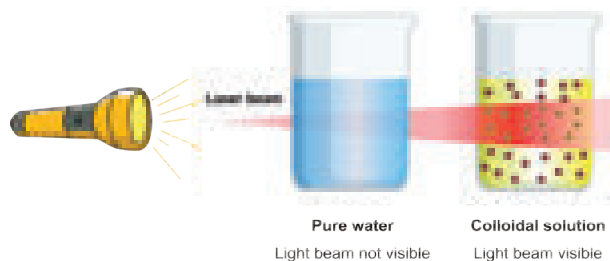

Figure 10.12 Tyndall effect

### Test Yourself

1. Why whole milk is white?
2. Why ocean is blue?
3. Why sun looks yellow when it is really not?

### 10.4.3 Emulsions - a special kind of colloids

An emulsion is a colloid of two or more immiscible liquids where one liquid is dispersed in another liquid. This means one type of liquid particles get scattered in another liquid. In other words, an emulsion is a special type of mixture made by combining two liquids that normally don't mix. The word emulsion comes from the

Latin word meaning “to milk” (milk is one example of an emulsion of fat and water). The process of turning a liquid mixture into an emulsion is called emulsification. Milk, butter, cream, egg yolk, paints, cough syrups, facial creams, pesticides etc. are some common examples of emulsions.

### Types of emulsions

The two liquids mixed can form different types of emulsions. For example, oil and water can form an oil in water emulsion (O/W -e.g. cream), where the oil droplets are dispersed in water, or they can form a water in oil emulsion (W/O -e.g. butter), with water dispersed in oil.

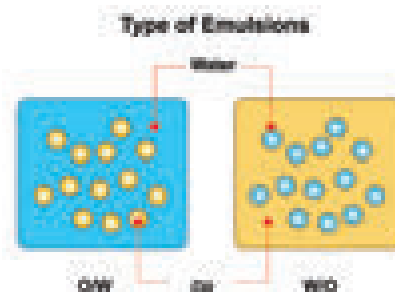
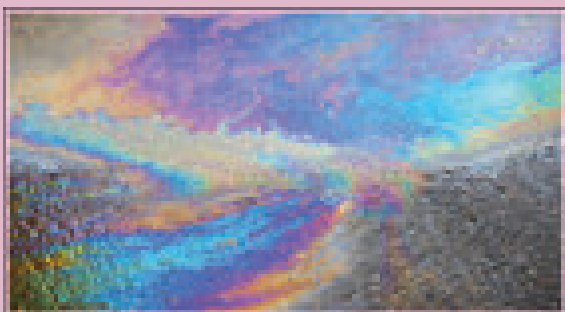

Figure 10.13 Emulsions

Emulsions find wide applications in food processing, pharmaceuticals, metallurgy and many other important industries.

### More to Know

Have you seen colourful patches on a wet road? When oil drops in water on road, it floats over water and forms a colourful film. Find out why.



### Points to Remember

- ❖ Depending upon the chemical composition, matter is classified into elements, compounds and mixtures
- ❖ Elements and compounds are considered to be pure substances as they contain only one kind of particles whereas mixtures contain more than one type of particles and they are considered as impure substances
- ❖ In a homogenous mixture (true solution) the components are uniformly mixed and it will have single phase
- ❖ A heterogeneous mixture are not mixed thoroughly or uniformly and it will have more than single phase
- ❖ Based on the size of the solute particles heterogeneous mixtures can be classified as colloidal solutions and suspensions

## A-Z GLOSSARY

<b>Elements</b>	A substance composed of atoms having an identical number of protons in each nucleus.
<b>Compounds</b>	A pure, macroscopically homogeneous substance consisting of atoms or ions of two or more different elements in definite proportions.
<b>Mixtures</b>	A composition of two or more substances that are not chemically combined with each other and are capable of being separated.
<b>Solution</b>	Homogeneous mixture composed of two or more substances.
<b>Colloid</b>	A system in which finely divided particles, which are approximately 1 to 100 nm in size, are dispersed within a continuous medium in a manner that prevents them from being filtered easily or settled rapidly.
<b>Suspension</b>	A suspension is a heterogeneous mixture in which solute-like particles settle out of a solvent-like phase sometime after their introduction
<b>Emulsion</b>	A colloid in which both phases are liquids: an oil-in-water emulsion.
<b>Absorption</b>	Process by which atoms, molecules, or ions enter a bulk phase (liquid, gas, solid)
<b>Adsorption</b>	Adhesion of atoms, ions or molecules from a gas, liquid or dissolved solid to a surface
<b>Centrifugation</b>	Sedimentation of particles under the influence of the centrifugal force and it is used for separation of superfine suspensions.



## TEXTBOOK EXERCISES



### I. Choose the correct answer.

- The separation of denser particles from lighter particles done by rotation at high speed is called \_\_\_\_\_  
a) Filtration      b) sedimentation  
c) decantation      d) centrifugation
- Among the following \_\_\_\_\_ is a mixture  
a) Common Salt      b) Juice  
c) Carbon dioxide      d) Pure Silver
- When we mix a drop of ink in water we get a \_\_\_\_\_  
a) Heterogeneous Mixture      b) Compound  
c) Homogeneous Mixture      d) Suspension
- \_\_\_\_\_ is essential to perform separation by solvent extraction method.  
a) Separating funnel      b) filter paper  
b) centrifuge machine      d) sieve
- \_\_\_\_\_ has the same properties throughout the sample  
a) Pure substance      b) Mixture  
c) Colloid      d) Suspension

### II. State whether true or false. If false, correct the statement.

- Oil and water are immiscible with each other.
- A compound cannot be broken into simpler substances chemically.
- Liquid – liquid colloids are called gel.
- Buttermilk is an example of heterogeneous mixture.
- Aspirin is composed of 60% Carbon, 4.5% Hydrogen and 35.5% Oxygen by mass. Aspirin is a mixture.

### III. Match the following.

Element	Settles down on standing
Compound	Impure substance
Colloid	Made up of molecules
Suspension	Pure substance
Mixture	Made up of atoms

### IV. Fill in the blanks.

- A \_\_\_\_\_ mixture has no distinguishable boundary between its components.
- An example of a substance that sublimes is \_\_\_\_\_
- Alcohol can be separated from water by \_\_\_\_\_
- In petroleum refining, the method of separation used is \_\_\_\_\_
- Chromatography is based on the principle of \_\_\_\_\_

### V. Answer very briefly.

- Differentiate between absorption and adsorption.
- Define Sublimation.
- A few drops of 'Dettol' when added to water the mixture turns turbid. Why?
- Name the apparatus that you will use to separate the components of mixtures containing two, i. miscible liquids, ii. immiscible liquids.
- Name the components in each of the following mixtures.  
i. Ice cream      ii. Lemonade  
iii. Air      iv. Soil

## VI. Answer briefly.

1. Which of the following are pure substances? Ice, Milk, Iron, Hydrochloric acid, Mercury, Brick and Water.
2. Oxygen is very essential for us to live. It forms 21% of air by volume. Is it an element or compound?
3. You have just won a medal made of 22-carat gold. Have you just procured a pure substance or impure substance?
4. How will you separate a mixture containing saw dust, naphthalene and iron filings?
5. How are homogenous solutions different from heterogeneous solution? Explain with examples.

## VII. Answer in detail.

1. Write the differences between elements and compounds and give an example for each.
2. Explain Tyndall effect and Brownian movement with suitable diagram.
3. How is a mixture of common salt, oil and water separated? You can use a combination of different methods.



## REFERENCE BOOKS

1. A Textbook of Physical Chemistry, K.K. Sharma & L.K. Sharma S.Chand publishing.
2. Materials, Matter and Particles A Brief History By (author): Michael M Woolfson (University of York, UK)
3. Suresh S, Keshav A. "Textbook of Separation Processes", Studium Press (India) Pvt. Ltd.



## INTERNET RESOURCES

1. <http://www.worldscientific.com/worldscibooks/10.1142/P671>
2. <http://www.chemteam.info/ChemTeamIndex.html>
3. [http://www.chem4kids.com/files/matter\\_solution2.html](http://www.chem4kids.com/files/matter_solution2.html)
4. <https://www.youtube.com/watch?v=loakplUEZYQ>

## Concept Map

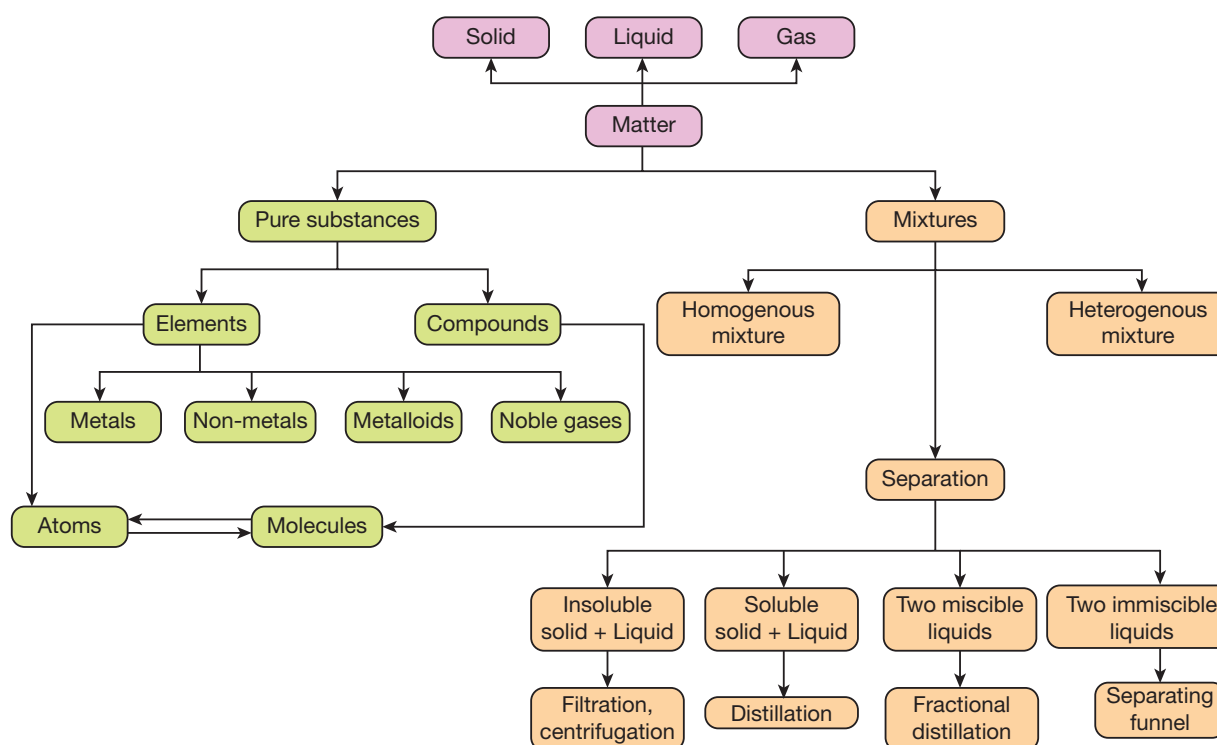



### Learning Objectives



After studying this chapter, students will be able to

- understand Rutherford's gold foil experiment.
- identify the limitations of Rutherford's model.
- explain the main postulates of Bohr's atomic model.
- compare the charge and mass of sub-atomic particles.
- calculate number of protons, neutrons and electrons from the given atomic number and mass number of an element.
- draw the atomic structure of first 20 elements.
- differentiate isotopes, isobars and isotones.
- assign valency of various elements based on the number of valence electrons.
- recognize the significance of quantum numbers.
- state and illustrate the laws of multiple proportion, reciprocal proportion and combining volumes.

### Introduction

Just as a small child wants to take a toy apart to find out what is inside, scientists have for long been curious about the internal structure of an atom. They wanted to find out what are the particles present inside an atom and how are these particles arranged in an atom. For explaining this many scientists proposed various atomic models.

We have learnt Dalton's atomic theory and J.J. Thomson's model in class VIII. Now we will learn about sub-atomic particles and the other atomic models to explain how these particles are arranged within an atom.

#### 11.1 Discovery of Nucleus

In 1911, Lord Rutherford, a scientist from New Zealand, performed his famous

experiment of bombarding a thin gold foil with very small positively charged particles called alpha( $\alpha$ ) particles. He selected a gold foil because, he wanted as thin layer as possible and gold is the most malleable metal.

He observed that:

1. Most of the alpha particles passed straight through the foil.
2. Some alpha particles were slightly deflected from their straight path.
3. Very few alpha particles completely bounced back.



Figure 11.1 Deflected  $\alpha$ -particle

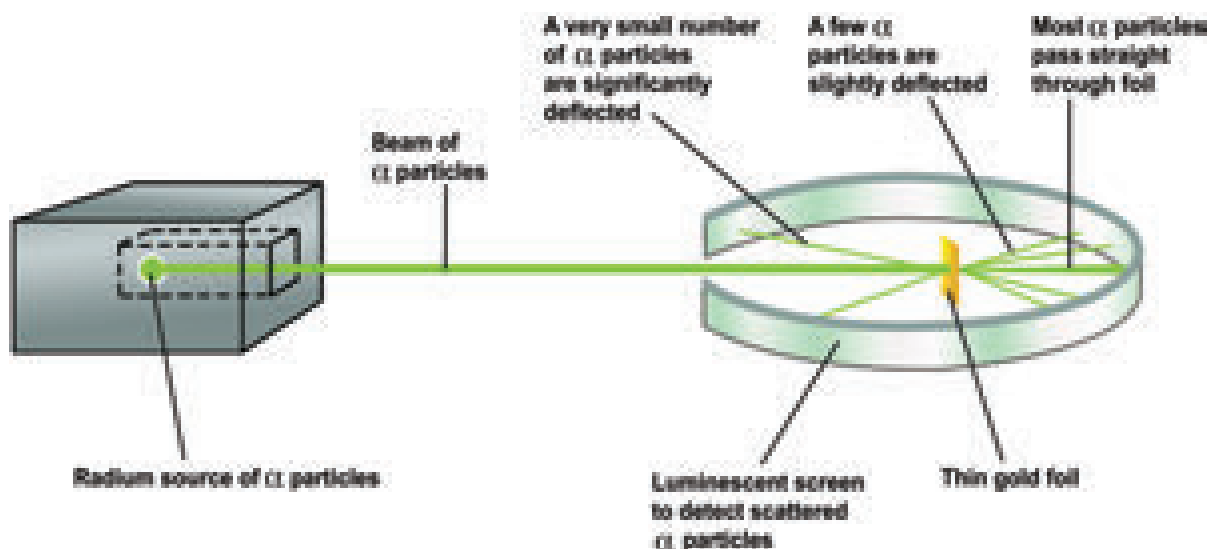

**Figure 11.2** Deflection of  $\alpha$ -particle by a gold leaf

Later, Rutherford generalized these results of alpha particles scattering experiment and suggested a model of the atom that is known as Rutherford's Atomic model.

### 11.1.1 Rutherford's Atomic model

According to this model :

- i. The atom contains large empty space.
- ii. There is a positively charged mass at the centre of the atom, known as nucleus.
- iii. The size of the nucleus of an atom is very small compared to the size of an atom.
- iv. The electrons revolve around the nucleus in close circular paths called orbits.
- v. An atom as a whole is electrically neutral, i.e., the number of protons and electrons in an atom are equal.

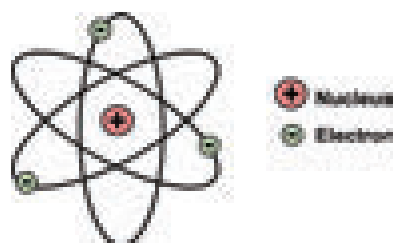

**Figure 11.3** Rutherford's model of the atom was somewhat like that of the solar system.

Rutherford's model of atomic structure is similar to the structure of the solar system. Just

as in the solar system, the Sun is at the centre and the planets revolve around it, similarly in an atom the nucleus is present at the centre and the electrons revolve around it in orbits or shells.

### 11.1.2 Limitations in Rutherford's model

According to Electromagnetic theory, a moving electron should accelerate and continuously lose energy. Due to the loss of energy, the path of the electron may reduce and finally the electron should fall into the nucleus. If it happens so, the atom becomes unstable. But atoms are stable. Thus, Rutherford's model failed to explain the stability of an atom.

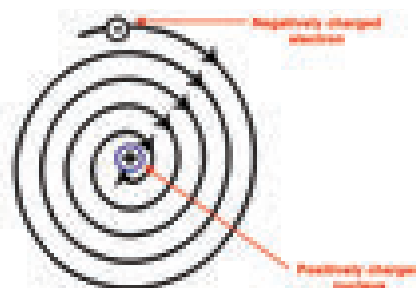

**Figure 11.4** Showing an atom losing energy.

## 11.2 Bohr's model of an atom

In 1913, Neils Bohr, a Danish physicist, explained the causes of the stability of the atom in a different manner. The main postulates are:



- In atoms, the electron revolve around the nucleus in stationary circular paths called orbits or shells or energy levels.
- While revolving around the nucleus in an orbit, an electron neither loses nor gains energy.
- An electron in a shell can move to a higher or lower energy shell by absorbing or releasing a fixed amount of energy.
- The orbits or shells are represented by the letters K,L,M,N,... or the numbers,  $n=1,2,3,4,\dots$

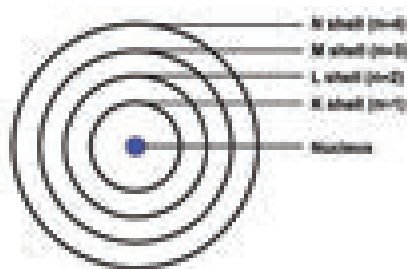

**Figure 11.5** Energy levels around the nucleus of an atom: Bohr's model.

The orbit closest to the nucleus is the K shell. It has the least amount of energy and the electrons present in it are called K electrons, and so on with the successive shells and their electrons. These orbits are associated with fixed amount of energy, so Bohr called them as **energy level** or **energy shells**.

### 11.2.1 Limitations of Bohr's model

One main limitation was that this model was applicable only to hydrogen and hydrogen like ions (example,  $\text{He}^+$ ,  $\text{Li}^{2+}$ ,  $\text{Be}^{3+}$ , and so on). It could not be extended to multi electron nucleus.

## 11.3 Discovery of Neutrons

In 1932 James Chadwick observed when Beryllium was exposed to alpha particles, particles with about the same mass as protons were emitted.

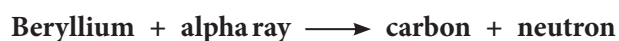

These emitted particles carried no electrical charges. They were called as neutrons. It is denoted by  ${}_0n^1$ . The superscript 1 represents its mass and subscript 0 represents its electric charge.

### Properties of Neutrons

- This particle was not found to be deflected by any magnetic or electric field, proving that it is electrically neutral.
- Its mass is equal to  $1.676 \times 10^{-24}$  g (**1 amu**).



In 1920 Rutherford predicted the presence of another particle in the nucleus as neutral. James Chadwick, the inventor of neutron was student of Rutherford

## 11.4 Characteristics of Fundamental particles

The atom is built up of a number of sub-atomic particles. The three sub-atomic particles of great importance in understanding the structure of an atom are electrons, protons and neutrons, the properties of which are given in Table 11.1.

**Table 11.1** Properties of sub-atomic particles

Particle	Symbol	Charge (electronic units)	mass (amu)	mass (grams)
Electron	${}_{-1}e^0$	-1	1/1837	$9.1 \times 10^{-28}$
Proton	${}_1H^1$	+1	1	$1.6 \times 10^{-24}$
Neutron	${}_0n^1$	0	1	$1.6 \times 10^{-24}$

There are two structural parts of an atom, the nucleus and the empty space in which there are imaginary paths called **orbits**.

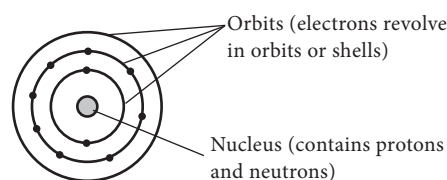

**Figure 11.6** Showing structure of an atom.

**Nucleus:** The protons and neutrons [collectively called **nucleons**] are found in the nucleus of an atom.

**Orbits:** Orbit is defined as the path, by which electrons revolve around the nucleus.



Besides the fundamental particles like protons, electrons and neutrons some more particles are discovered in the nucleus of an atom. They include mesons, neutrino, antineutrino, positrons etc.

## 11.5 Atomic number and Mass number

Only hydrogen atoms have one proton in their nuclei. Only helium atoms have two protons. Indeed, only gold atoms have 79 protons. This shows that the number of protons in the nucleus of an atom decides which element it is. This very important number is known as the **atomic number** (proton number, given the symbol  $Z$ ) of an atom.

Atomic number ( $Z$ ) = Number of protons = Number of electrons

Protons alone do not make up all of the mass of an atom. The neutrons in the nucleus also contribute to the total mass. The mass of the electron can be regarded as so small that it can be ignored. As a proton and a neutron have the same mass, the mass of a particular atom depends on the total number of protons and neutrons present. This number is called the **mass number** (or nucleon number, given the symbol  $A$ ) of an atom.

Mass number = Number of protons + Number of neutrons

For any element, the atomic numbers are shown as subscripts and mass number are shown as superscripts.

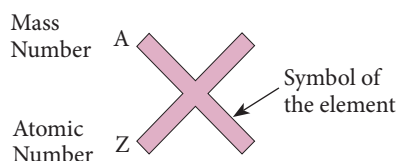

**For example,** nitrogen is written as  ${}^{14}_7\text{N}$

Here 7 is its atomic number and 14 is its mass number.

### Activity 1

Symbolically represent the following atoms using atomic number and mass number. [Refer table 11.1]

- a) Carbon                      b) Oxygen  
c) Silicon                      d) Beryllium

The difference between the mass number of an element and its atomic number gives the number of neutrons present in one atom of the element.

Number of neutrons ( $n$ ) = Mass number ( $A$ ) - Atomic number ( $Z$ )

**For example,** the number of neutrons in one atom of  ${}^{24}_{12}\text{Mg}$  is

$$\text{Number of neutrons } (n) = \frac{24}{(A)} - \frac{12}{(Z)} = 12$$

### Test Yourself

Calculate the number of neutrons in the following atoms:

- a)  ${}^{27}_{13}\text{Al}$     b)  ${}^{31}_{15}\text{P}$     c)  ${}^{190}_{76}\text{Os}$     d)  ${}^{54}_{24}\text{Cr}$



Atomic number is designated as  $Z$  why?

$Z$  stands for Zahl, which means NUMBER in German.

$Z$  can be called Atomzahl or atomic number.  $A$  is the symbol recommended in the ACS style guide instead of  $M$  (massenzahl in German).

### Problem 1

Calculate the atomic number of an element whose mass number is 39 and number of neutrons is 20. Also find the name of the element.

### Solution

$$\begin{aligned} \text{Mass Number} &= \text{Atomic number} + \text{Number of neutrons} \\ \text{Atomic Number} &= \text{Mass number} - \text{Number of neutrons} \\ &= 39 - 20 \\ \text{Atomic Number} &= 19 \end{aligned}$$

Element having atomic number 19 is Potassium (K)

### 11.5.1 Electronic configuration of atoms

You already know that electrons occupy different energy levels called orbits or shells. The distribution of electrons in different shells is called electronic configuration. This distribution of electrons is governed by certain rules or conditions, known as Bohr and Bury Rules of electronic configuration.

**Rule 1:** The maximum number of electrons that can be accommodated in a shell is equal to  $2n^2$  where 'n' is the serial number of the shell from the nucleus.

Shell	Value of (n)	Maximum number of electrons ( $2n^2$ )
K	1	$2 \times 1^2 = 2$
L	2	$2 \times 2^2 = 8$
M	3	$2 \times 3^2 = 18$
N	4	$2 \times 4^2 = 32$

**Rule 2:** Shells are filled in a **stepwise manner** in the increasing order of energy.

**Rule 3:** The outermost shell of an atom cannot have more than 8 electrons, even if it has capacity to accommodate more electrons. For example, electronic arrangement in calcium having 20 electrons is,

K	L	M	N
2	8	8	2

#### Problem 2

What is the Electronic configuration of Aluminium?

#### Solution

Electronic configuration of Aluminium atom: (Z = 13) **K shell = 2, L shell = 8 and M shell = 3 electron.**

So its electronic configuration is 2, 8, 3



The forces between the protons and the neutrons in the nucleus are of special kind called Yukawa forces. This strong force is more powerful than gravity.

### Geometric Representation of atomic structure of elements

Knowing the mass number and atomic number of an element we can represent atomic structure.

#### Example:

Geometric Representation of oxygen atom  ${}^{16}_8\text{O}$

Mass number A = 16

Atomic number Z = 8

Number of neutrons =  $A - Z = 16 - 8 = 8$

Number of protons = 8

Number of electron = 8

Electronic configuration = 2, 6

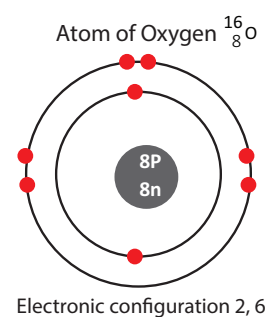

Figure 11.7 Atom of oxygen.



Atoms are so tiny their mass number cannot be expressed in grams but expressed in amu (atomic mass unit). New unit is U. Size of an atom can be measured in nano metre ( $1 \text{ nm} = 10^{-9} \text{ m}$ ) Even though atom is an invisible tiny particle now-a-days atoms can be viewed through SEM that is Scanning Electron Microscope.

### 11.5.2 Valence electrons

In the above example, we can see that there are six electrons in the outermost shell of oxygen atom. These six electrons are called as valence electrons.

The outermost shell of an atom is called valence shell and the electrons present in the valence shell are known as valence electrons. The chemical properties of elements are decided by these valence electrons, since they are the ones that take part in chemical reactions.

The elements with same number of electrons in the valence shell show similar properties and those with different number of valence electrons show different chemical properties. Elements, which have 1 or 2 or 3 valence electrons (except Hydrogen) are **metals**. Elements with 4 to 7 electrons in their valence shell are **non-metals**.

### 11.5.3 Valency

Valency of an element is the combining capacity of the element with other elements and is equal to the number of electrons that take part in a chemical reaction. Valency of the elements having valence electrons 1, 2, 3, 4 is 1, 2, 3, 4 respectively.

Valency of an element with 5, 6 and 7 valence electrons is 3, 2 and 1 (8–valence electrons)



respectively. Because 8 is the number of electrons required by an element to attain stable electronic configuration. Elements having completely filled outermost shell show **Zero valency**.

For example: The electronic configuration of Neon is 2,8 (completely filled). So valency is 0.

#### Problem 3

Find the valency of Magnesium and Sulphur.

#### Solution

Electronic configuration of magnesium is 2, 8, 2.  
So valency is 2.

Electronic configuration of sulphur is 2, 8, 6.  
So valency is 2 i.e. (8 – 6).

#### Activity 2

Assign the valency for Phosphorus, Chlorine, Silicon and Argon

**Table 11.2** Arrangement of electrons in atoms of elements having atomic from 1 to 20.

Elements	Symbol	Atomic No (Z) No. of protons/ No. of electrons	Mass No. (A) No. of protons + neutrons	No. of neutrons (A – Z)	Electronic configuration				Valency	Metal/ non-metal/ noble gas
					1st or K-shell	2nd or L-shell	3rd or M-shell	4th or N-shell		
Hydrogen	H	1	1	–	1				1	Non-metal
Helium	He	2	4	2	2				0	Noble gas
Lithium	Li	3	7	4	2	1			1	Metal
Beryllium	Be	4	9	5	2	2			2	Metal
Boron	B	5	11	6	2	3			3	Non-metal
Carbon	C	6	12	6	2	4			4	Non-metal
Nitrogen	N	7	14	7	2	5			3	Non-metal
Oxygen	O	8	16	8	2	6			2	Non-metal
Fluorine	F	9	19	10	2	7			1	Non-metal
Neon	Ne	10	20	10	2	8			0	Noble gas
Sodium	Na	11	23	12	2	8	1		1	Metal
Magnesium	Mg	12	24	12	2	8	2		2	Metal
Aluminium	Al	13	27	14	2	8	3		3	Metal
Silicon	Si	14	28	14	2	8	4		4	Non-metal
Phosphorus	P	15	31	16	2	8	5		3	Non-metal
Sulphur	S	16	32	16	2	8	6		2	Non-metal
Chlorine	Cl	17	35, 37	18, 20	2	8	7		1	Non-metal
Argon	Ar	18	40	22	2	8	8		0	Noble gas
Potassium	K	19	39	20	2	8	8	1	1	Metal
Calcium	Ca	20	40	20	2	8	8	2	2	Metal

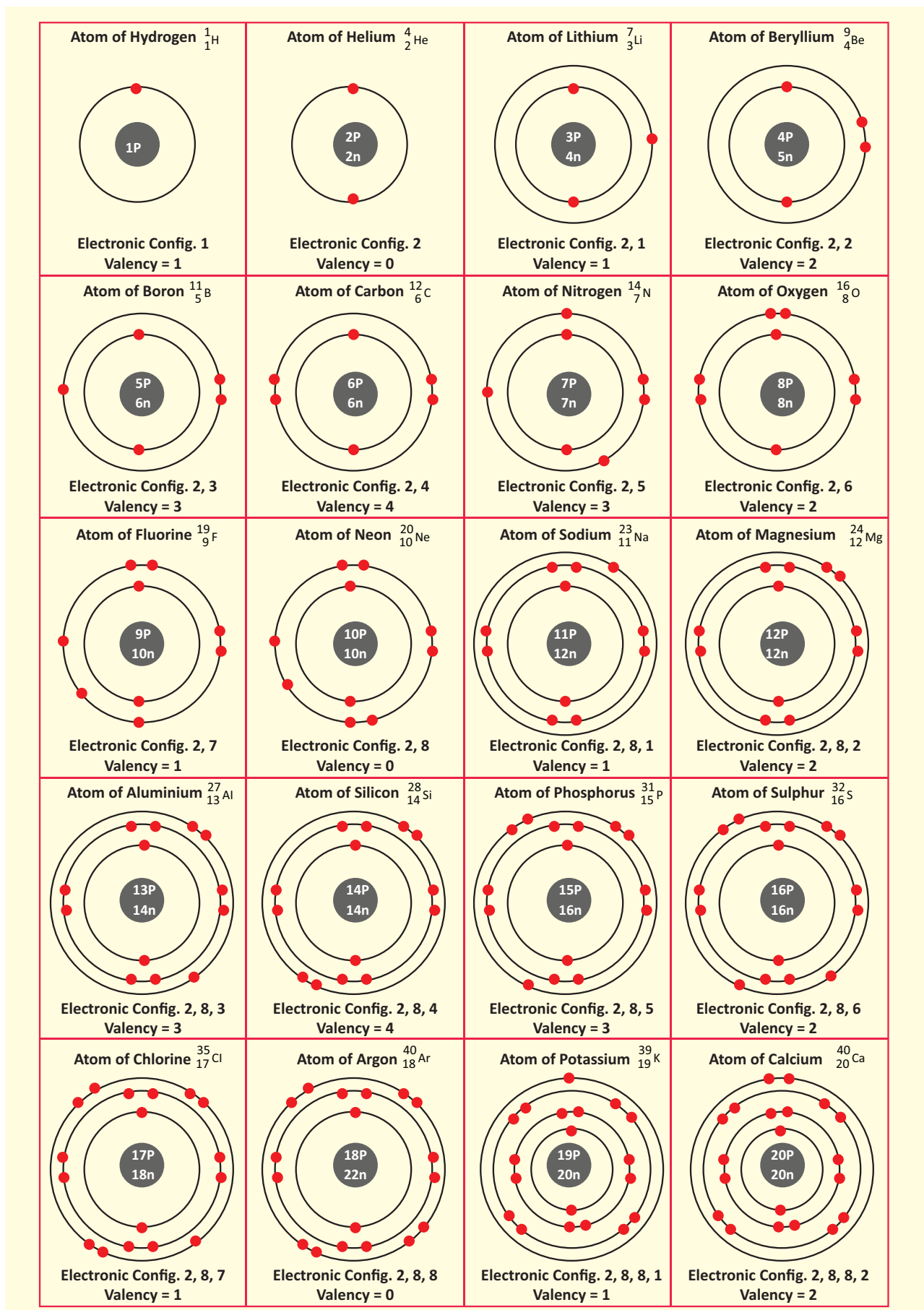
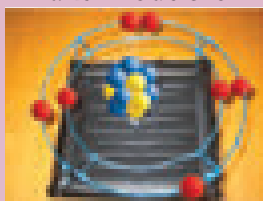

Figure 11.8 Geometric representation of atoms of the first twenty elements.

### Activity 3

Look at the model given below. Make groups of five. Each group can make models of 4 elements by using available materials like balls, beads, string etc.



### Activity 4

Draw the structures of the isotopes of oxygen  $O^{16}$  and  $O^{18}$

Atomic number of oxygen = 8

## 11.6 Isotopes, Isobars and Isotones

### 11.6.1 Isotopes

In nature, a number of atoms of elements have been identified, which have the same atomic number but different mass numbers. For example, take the case of hydrogen atom, it has three atomic species as shown below:

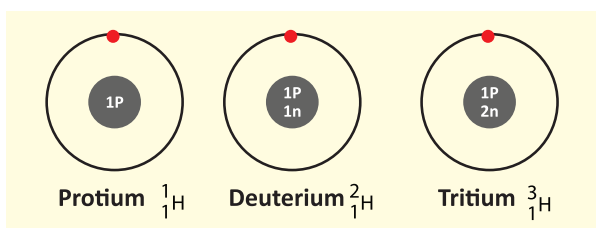

Figure 11.9 Isotopes

The atomic number of all the three isotopes is 1, but the mass number is 1, 2 and 3, respectively. Other such examples are: i) carbon,  ${}^{12}_6\text{C}$ ,  ${}^{13}_6\text{C}$  ii) Chlorine  ${}^{35}_{17}\text{Cl}$ ,  ${}^{37}_{17}\text{Cl}$

On the basis of these examples, isotopes are defined as the different atoms of the same element, having same atomic number but different mass numbers. There are two types of isotopes: **stable** and **unstable**. The isotopes which are unstable, as a result of the extra neutrons in their nuclei are radioactive and are called **radioisotopes**. For example, uranium-235, which is a source of nuclear reactors, and cobalt-60, which is used in radiotherapy treatment are both radioisotopes.

### 11.6.2 Isobars

Let us consider two elements – calcium (atomic number 20), and argon (atomic number 18).

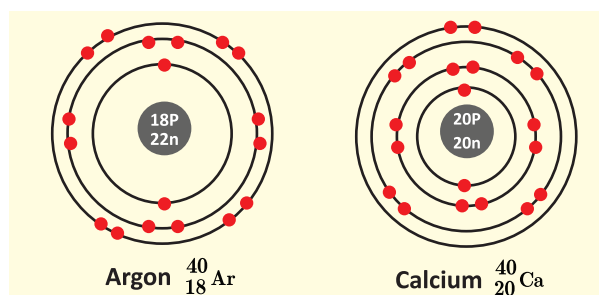

Figure 11.10 Isobars

They have (Fig. 11.10) different number of protons and electrons. But, the mass number of both these elements is 40. It follows that the total number of nucleons in both the atoms are the same. They are called isobars. Atoms of different elements with different atomic numbers, and same mass number are known as isobars.

### More to Know

Thumb rule for isotopes and isobars. Remember **t** for top and **b** for bottom.  
Isotope: Top value changes – Atomic mass  
Isobars: Bottom value changes – Atomic number

### 11.6.3 Isotones

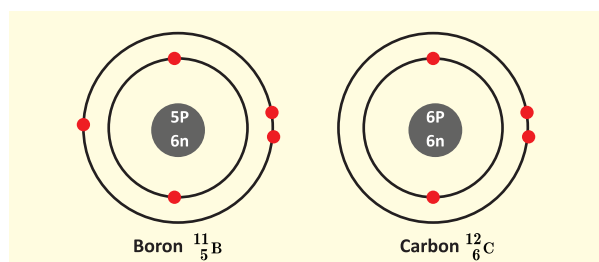

Figure 11.11 Isotones



No of neutrons in boron =  $11 - 5 = 6$

No of neutrons in carbon =  $12 - 6 = 6$

The above pair of elements Boron and Carbon has the same number of neutrons but different number of protons and hence different atomic numbers. Atoms of different elements with different atomic numbers and different mass numbers, but with same number of neutrons are called isotones

### Activity 5

Draw the model of the following pairs of isotones:

- (i) Fluorine & Neon
- (ii) Sodium & Magnesium
- (iii) Aluminum and Silicon

## 11.7

### Laws of Chemical combination

In the seventeenth century, scientists had been trying to find out methods for converting one substance into another. During their studies of chemical changes, they made certain generalisations. These generalisations are known as laws of chemical combination. These are :

1. Law of conservation of mass
2. Law of constant proportions
3. Law of multiple proportions
4. Law of reciprocal proportions
5. Gay Lussac's law of gaseous volumes

Out of these five laws you have already learnt the first two laws in class VIII. Let us see the next three laws in detail in this chapter.

#### 11.7.1 Law of multiple proportions

This law was proposed by John Dalton in 1804.

It states that, "When two elements A and B combine together to form more than one compound, then different masses of A which separately combine with a fixed mass of B are in simple ratio".

To illustrate the law let us consider the following example.

Carbon combines with oxygen to form two different oxides, carbon monoxide(CO) and carbon dioxide (CO<sub>2</sub>). The ratio of masses of oxygen in CO and CO<sub>2</sub> for fixed mass of carbon is 1: 2.

	Mass of carbon (g)	Mass of oxygen (g)	Ratio of O in CO to O in CO <sub>2</sub>
CO	12	16	1:2
CO <sub>2</sub>	12	32	

Let us take one more example, Sulphur combines with oxygen to form sulphur dioxide and sulphur trioxide. The ratio of masses of oxygen in SO<sub>2</sub> and SO<sub>3</sub> for fixed mass of Sulphur is 2:3.

#### 11.7.2 Law of Reciprocal Proportions

The law of reciprocal proportions was proposed by Jeremias Richter in 1792.

It states that, "If two different elements combine separately with the same weight of a third element, the ratio of the masses in which they do so are either same or a simple multiple of the mass ratio in which they combine among themselves."

Consider the three elements hydrogen, oxygen and water as shown below:

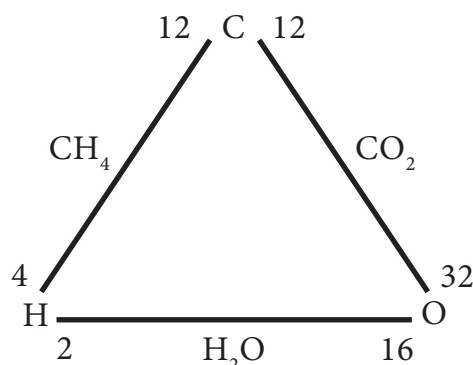

Here, hydrogen and oxygen combine separately with the same weight of carbon to form methane (CH<sub>4</sub>) and carbon dioxide (CO<sub>2</sub>)

Compounds	Combining elements		Combining weights	
CH <sub>4</sub>	C	H	12	4
CO <sub>2</sub>	C	O	12	32

Ratio of different mass of hydrogen (4g) and oxygen (32g) that combines with same mass of carbon } 4:32 (or) 1:8 ———(1)

Now, hydrogen and oxygen combine to form water (H<sub>2</sub>O).

Ratio of mass of hydrogen to oxygen = 2:16 (or) 1:8 ———(2)

From 1 and 2, the ratio is the same as that of the first obtained. Thus, the law of reciprocal proportion is illustrated.

### 11.7.3 Gay Lussac's Law of Combining Volumes

According to Gay Lussac's Law, whenever gases react together, the volumes of the reacting gases bear a simple ratio, and the ratio is extended to the product when the product is also in gaseous state, provided all the volumes are measured under similar conditions of temperature and pressure.

This law may be illustrated by the following example.

It has been experimentally observed that two volumes of hydrogen reacts with one volume of oxygen to form two volumes of water as shown in the figure 11.12.

The ratio of volume which gases bears is 2:1:2 which is a simple whole number ratio.

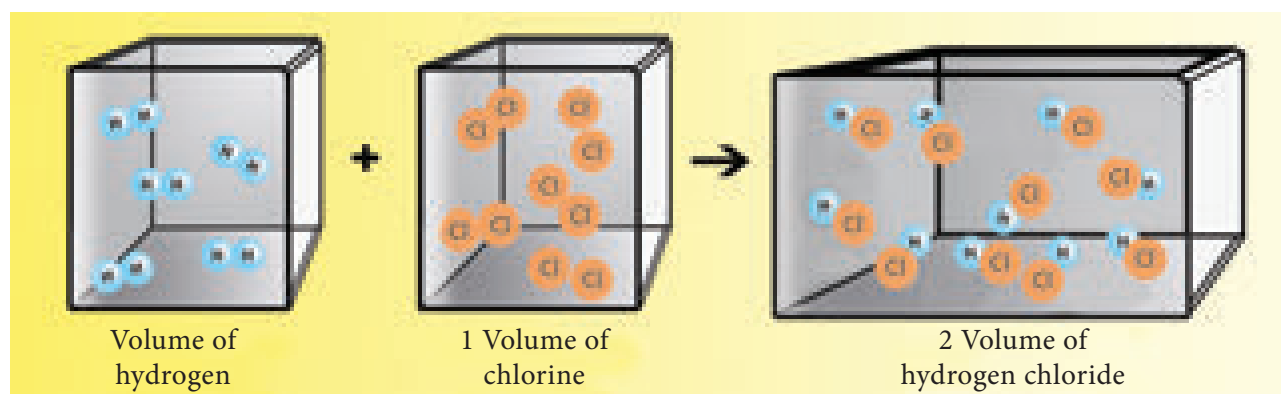

**Figure 11.12** One volume of hydrogen react with one volume of chlorine to give two volumes of hydrogen chloride.

### Activity 6

Nitrogen combines with hydrogen to form ammonia (NH<sub>3</sub>). Illustrate Gay Lussac's law using this example.

## 11.8 Quantum Numbers

When you specify the location of a building, you usually list which country it is in, which state and city it is in that country.

Just like we have four ways of defining the location of a building (country, state, city, and street address), we have four ways of defining the properties of an electron, i.e. four quantum numbers.

Thus, the numbers which designate and distinguish various atomic orbitals and electrons present in an atom are called quantum numbers.

Four types of Quantum number are as follows:

Quantum Number	Symbol	Information conveyed
Principal quantum number	$n$	Main energy level
Azimuthal quantum number	$l$	Sub shell/ shape of orbital
Magnetic quantum number	$m$	Orientation of orbitals
Spin quantum number	$s$	Spin of the electron

You will learn more details about this in higher classes.

### Points to Remember

- ❖ Rutherford's alpha-particle scattering experiment led to the discovery of the atomic nucleus.
- ❖ J.Chadwick discovered the presence of neutrons in the nucleus.
- ❖ Mass number of an element is the total number of protons and neutrons.
- ❖ Valence electrons are the electrons in the outermost orbit.
- ❖ Valency is the combining capacity of an atom.
- ❖ Isotopes are atoms of the same element, which have same atomic number but different mass numbers.
- ❖ Isobars are the atoms of the different element with same mass number but different atomic number.
- ❖ Isotones are the atoms of different elements having same number of neutron but different atomic number and mass number.

### A-Z GLOSSARY

<b>Atom</b>	The smallest component of an element which takes part in a chemical reaction.
<b>Electron</b>	A stable subatomic particle with a charge of negative electricity, found in all atoms and acting as the primary carrier of electricity in solids.
<b>Neutron</b>	A subatomic particle of about the same mass as a proton but without an electric charge, present in all atomic nuclei except those of ordinary hydrogen.
<b>Orbitals</b>	Atomic orbitals are region of space around the nucleus of an atom where an electron is likely to be found.
<b>Proton</b>	A stable subatomic particle occurring in all atomic nuclei, with a positive electric charge equal in magnitude to that of an electron.
<b>Quantum numbers</b>	The numbers which designate and distinguish various atomic orbitals and electrons present in an atom.



### TEXTBOOK EXERCISES

#### I. Choose the correct answer.

- Among the following the odd pair is
  - ${}_{8}^{18}\text{O}$ ,  ${}_{9}^{19}\text{F}$
  - ${}_{18}^{40}\text{Ar}$ ,  ${}_{7}^{14}\text{N}$
  - ${}_{14}^{30}\text{Si}$ ,  ${}_{15}^{31}\text{P}$
  - ${}_{20}^{40}\text{Cr}$ ,  ${}_{19}^{39}\text{K}$
- Change in the number of neutrons in an atom changes it to
  - an ion.
  - an isotope.
  - an isobar.
  - another element.
- The term nucleons refer to
  - protons and electrons
  - only neutrons
  - electrons and neutrons
  - protons and neutrons
- The number of protons, neutrons and electrons present respectively in  ${}_{35}^{80}\text{Br}$  are
  - 80, 80, 35
  - 35, 55, 80
  - 35, 35, 80
  - 35, 45, 35
- The correct electronic configuration of potassium is
  - 2,8,9
  - 2,8,1
  - 2,8,8,1
  - 2,8,8,3



## II. State true or false. If false, correct the statement.

1. In an atom, electrons revolve around the nucleus in fixed orbits.
2. Isotopes of an element have different atomic numbers.
3. Electrons have negligible mass and charge.
4. Smaller the size of the orbit, lower is the energy of the orbit.
5. The maximum number of electron in L Shell is 10.

## III. Fill in the blanks.

1. Calcium and Argon are examples of a pair of \_\_\_\_\_
2. Total number of electrons that can be accommodated in an orbit is given by \_\_\_\_\_
3. \_\_\_\_\_ isotope is used in the nuclear reactors.
4. The number of neutrons present in  ${}^7_3\text{Li}$  is \_\_\_\_\_
5. The valency of Argon is \_\_\_\_\_

## IV. Match the following.

a) Dalton	1. Hydrogen atom model
b) Chadwick	2. Discovery of nucleus
c) Rutherford	3. First atomic theory
d) Neils Bohr	4. Plum pudding model
	5. Discovery of neutrons

## V. Complete the following table.

Atomic Number	Mass Number	Number of Neutrons	Number of Protons	Number of Electrons	Name of the Element
9	-	10	-	-	-
16	-	16	-	-	-
-	24	-	-	12	Magnesium
-	2	-	1	-	-
-	1	0	1	1	-

## VI. Answer very briefly.

1. Name an element which has the same number of electrons in its first and second shell.
2. Write the electronic configuration of K and Cl
3. Write down the names of the particles represented by the following symbols and explain the meaning of superscript and subscript numbers attached.

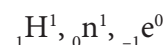

4. For an atom 'X', K, L and M shells are completely filled. How many electrons will be present in it?
5. What is the same about the electron structures of:
  - a. Lithium, Sodium and Potassium.
  - b. Beryllium, Magnesium and Calcium.

## VII. Answer briefly.

1. How was it shown that atom has empty space?
2. Why do  ${}^{35}_{17}\text{Cl}$  and  ${}^{37}_{17}\text{Cl}$  have the same chemical properties? In what respect do these atoms differ?
3. Draw the structure of oxygen and sulphur atoms.
4. Calculate the number of neutrons, protons and electrons: (i) atomic number 3 and mass number 7 (ii) atomic number 92 and mass number 238.
5. What are nucleons? How many nucleons are present in Phosphorous? Draw its structure.

### VIII. Answer in detail.

1. What conclusions were made from the observations of Gold foil experiment?
2. Explain the postulates of Bohr's atomic model.
3. State the Gay Lussac's law of combining volumes. Explain with an illustration.



### REFERENCE BOOKS

1. Atomic Structure Rebecca L. Johnson  
Twenty-First Century Books.

2. Atomic structure and Periodicity Jack Barrett. Royal Society of Chemistry.
3. Chemistry for Degree Students (B.Sc. Sem.-I, As per CBCS) R L Madan.



### INTERNET RESOURCES

<https://www.youtube.com/watch?v=t4xgv1NFQ3c>

<https://www.youtube.com/watch?v=P6DMEgE8CK8>

<https://www.youtube.com/watch?v=YURReI6OJsg>

### Concept Map

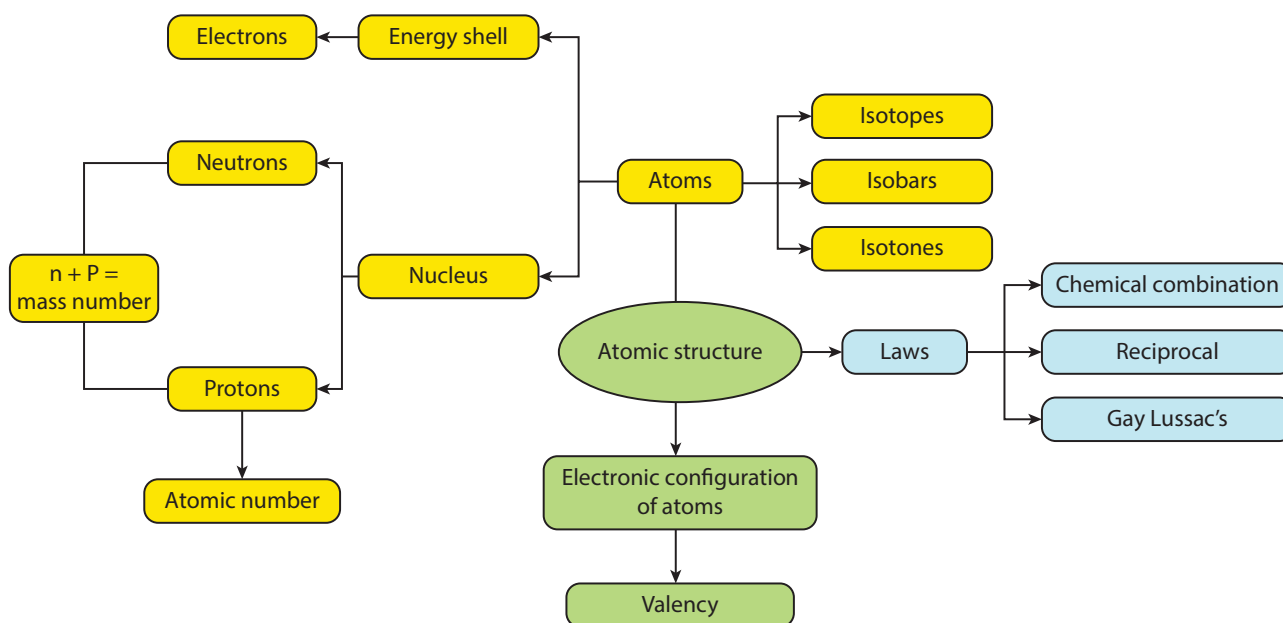

### ICT CORNER

#### ATOMIC STRUCTURE

Atoms are building blocks. They are made of neutrons, protons and electrons. This activity help the students to explore more about atoms and its components.

**Step 1.** Type the following URL in the browser or scan the QR code from your mobile. You can see on the screen. Click that.

**Step 2.** Select atom. Atomic orbit you can see with multiple options. Select protons, neutrons and electrons to their respective places. According to their numbers name of the elements appear on the periodic table. You can also find out whether the selected element is neutral or charged(ions)

**Step 3.** click“symbol”now. When you arrange electrons, neutrons and protons on the orbits you can see the name of the element, it's atomic number, atomic mass and number of electrons.

**Step 4.** Third option is games. It's an evaluation one to test your understanding

**URL:** [https://phet.colorado.edu/sims/html/build-an-atom/latest/build-an-atom\\_en.html](https://phet.colorado.edu/sims/html/build-an-atom/latest/build-an-atom_en.html)



B567\_9\_SCI\_EM\_T3

## UNIT

# 12

# PERIODIC CLASSIFICATION OF ELEMENTS

## Learning Objectives



After completing this lesson, students will be able to

- know the concept of classification of elements in early days.
- understand the postulates, advantages and limitations of modern periodic table.
- understand the classification of elements based on the electronic configuration.
- learn about the position of hydrogen in the periodic table.
- study about the position of rare gases (Noble gases) in the periodic table.
- distinguish between metals and non-metals.
- know about metalloids and alloys.

## Introduction

We live in the world of substances with great diversity. Substances are formed by the combination of various elements. All the elements are unique in their nature and property. To categorize these elements according to their properties, scientists started to look for a way. In 1800, there were only 31 known elements. By 1865, their number became 63. Now 118 elements have been discovered. As different elements were being discovered, scientists gathered more and more information about the properties of these elements. They found it difficult to organize all that was known about the elements. They started looking for some pattern in their properties, on the basis of which they could study such a large number of elements with ease. Let us discuss the concepts of classification of elements proposed by various scientists from early to modern period.

## 12.1. Early Concepts of Classification of Elements

### 12.1.1. Dobereiner's Triads

In 1817, Johann Wolfgang Dobereiner, a German chemist, suggested a method of grouping elements based on their relative atomic masses. He arranged the elements into groups containing three elements each. He called these groups as 'triads' (tri – three).

Dobereiner showed that **when the three elements in a triad are arranged in the ascending order of their atomic masses, the atomic mass of the middle element is nearly the same as average of atomic masses of other two elements.** This statement is called the Dobereiner's law of triads. Table 12.1 shows the law of triads proposed by Dobereiner.

Example: In the triad group (1), arithmetic mean of atomic masses of 1st and 3rd elements,

**Table 12.1** Dobereiner's law of triads

Triad Group (1)		Triad Group (2)		Triad Group (3)	
Element	Atomic Mass	Element	Atomic Mass	Element	Atomic Mass
Li	6.9	Cl	35.5	Ca	40.1
Na	23	Br	79.9	Sr	87.6
K	39.1	I	126.9	Ba	137.3

$(6.9 + 39.1)/2 = 23$ . So the atomic mass of Na (middle element) is 23.

**Limitations:**

- Dobereiner could identify only three triads from the elements known at that time and all elements could not be classified in the form of triads.
- The law was not applicable to elements having very low and very high atomic mass.

### 12.1.2 Newlands' Law of Octaves

In 1866, John Newlands arranged 56 known elements in the increasing order of their atomic mass. He observed that every eighth element had properties similar to those of the first element like the eighth note in an octave of music is similar to the first. This arrangement was known as 'law of octaves'.

The octave of Indian music system is sa, re, ga, ma, pa, da, ni, sa. The first and last notes of this octave are same i.e. sa. Likewise, in the Newlands' table of octaves, the element 'F' is eighth from the element 'H', thus they have similar properties.

#### Activity 1

Find the pair of elements having similar properties by applying Newlands' law of Octaves (Example: Mg & Ca):

Set I : F, Mg, C, O, B

Set II: Al, Si, S, Cl, Ca

**Limitations:**

- ❖ There are instances of two elements being fitted into the same slot, e.g. cobalt and nickel.

- ❖ Some elements, totally dissimilar in their properties, were fitted into the same group. (Arrangement of Co, Ni, Pd, Pt and Ir in the row of halogens)
- ❖ The law of octaves was not valid for elements that had atomic masses higher than that of calcium.
- ❖ Newlands' table was restricted to only 56 elements and did not leave any room for new elements.
- ❖ Discovery of inert gases (Neon, Argon....) at later stage made the 9th element similar to the first one. Eg: Neon between Fluorine and Sodium.

### 12.1.3 Mendeleev's Periodic Table

In 1869, Russian chemist, Dmitri Mendeleev observed that the elements of similar properties repeat at regular intervals when the elements are arranged in the order of their atomic masses. Based on this, he proposed the law of periodicity which states that "the physical and chemical properties of the elements are the periodic functions of their atomic masses". He arranged 56 elements known at that time according to his law of periodicity. This was best known as the short form of periodic table.

**(a) Features of Mendeleev's Periodic Table:**

- ❖ It has eight vertical columns called 'groups' and seven horizontal rows called 'period'.
- ❖ Each group has two subgroups 'A' and 'B'. All the elements appearing in a group were found to have similar properties.
- ❖ For the first time, elements were comprehensively classified in such a way that elements of similar properties were placed in the same group.

**Table 12.2** Newland's table of octaves (oct- eight)

No.	No.	No.	No.	No.	No.	No.	No.	No.
H 1	F 8	Cl 15	Co & Ni 22	Br 29	Pd 36	I 42	Pt & Ir 50	
Li 2	Na 9	K 16	Cu 23	Rb 30	Ag 37	Cs 44	Os 51	
G 3	Mg 10	Ca 17	Zn 24	Sr 31	Cd 38	Ba & V 45	Hg 52	
Bo 4	Al 11	Cr 19	Y 25	Ce & La 33	U 40	Ta 46	Ti 53	
C 5	Si 12	Ti 18	In 26	Zr 32	Sn 39	W 47	Pb 54	
N 6	P 13	Mn 20	As 27	Di & Mo 34	Sb 41	Nb 48	Bi 55	
O 7	S 14	Fe 21	Se 28	Ro & Ru 35	To 43	Au 49	Th 56	

- ❖ It was noticed that certain elements could not be placed in their proper groups in this manner. The reason for this was wrongly determined atomic masses. Consequently those wrong atomic masses were corrected. Eg: The atomic mass of beryllium was known to be 14. Mendeleev reassessed it as 9 and assigned beryllium a proper place.
- ❖ Columns were left vacant for elements which were not known at that time and their properties also were predicted. This gave motivation to experiment in Chemistry. Eg: Mendeleev gave names Eka Aluminium

and Eka Silicon to those elements which were to be placed below Aluminium and Silicon respectively in the periodic table and predicted their properties. The discovery of Germanium later on, during his life time, proved him correct.

**(b) Limitations:**

- ❖ Elements with large difference in properties were included in the same group. Eg: Hard metals like copper (Cu) and silver (Ag) were included along with soft metals like sodium (Na) and potassium (K).

**Table 12.3** Mendeleev's Periodic Table

Group	I	II	III	IV	V	VI	VII	VIII
Oxide:	R <sub>2</sub> O	RO	R <sub>2</sub> O <sub>3</sub>	RO <sub>2</sub>	R <sub>2</sub> O <sub>5</sub>	RO <sub>3</sub>	R <sub>2</sub> O <sub>7</sub>	RO <sub>4</sub>
Hydride:	RH	RH <sub>4</sub>	RH <sub>4</sub>	RH <sub>4</sub>	RH <sub>3</sub>	RH <sub>2</sub>	RH	
Periods	A B	A B	A B	A B	A B	A B	A B	Transition series
1	H 1.008							
2	Li 6.939	Be 9.012	B 10.81	C 12.011	N 14.007	O 15.999	F 18.988	
3	Na 22.99	Mg 22.99	Al 24.31	Si 28.09	P 30.974	S 32.06	Cl 35.453	
4 First Series	K 39.102	Ca 40.08	Sc 44.96	Ti 47.90	V 50.94	Cr 50.20	Mn 54.94	Fe 55.85
Second series	Cu 63.54	Zn 65.54	Ga 69.72	Ge 72.59	As 74.92	Se 78.96	Br 79.909	Co 58.93
5 First Series	Rb 85.47	Sr 87.62	Y 88.91	Zr 91.22	Nb 92.91	Mo 95.94	Tc 99	Ru 101.07
Second series	Ag 107.87	Cd 112.40	In 114.82	Sn 118.69	Sb 121.60	Te 127.60	I 126.90	Rh 102.91
6 First Series	Cs 132.90	Ba 137.34	La 138.91	Hf 178.40	Ta 180.95	W 183.85		Pd 106.4
Second series	Au 196.97	Hg 200.59	Tl 204.37	Pb 207.19	Bi 208.98			Ir 192.2
7	Rn 222	Fr 223	Ra 226	Ac 227	Th 232	Pa 231	U 238	Os 190.2
								Pt 195.05



- ❖ No proper position could be given to the element hydrogen. Non-metallic hydrogen was placed along with metals like lithium (Li), sodium (Na) and potassium (K).
- ❖ The increasing order of atomic mass was not strictly followed throughout. Eg. Co & Ni, Te & I.
- ❖ No place for isotopes in the periodic table.

**Table 12.4** Properties of Germanium

Property	Mendeleev's prediction (1871)	Actual property (1886)
Atomic Mass	About 72	72.59
Specific Gravity	5.5	5.47
Colour	Dark grey	Dark grey
Formula of Oxide	EsO <sub>2</sub>	GeO <sub>2</sub>
Nature of Chloride	EsCl <sub>4</sub>	GeCl <sub>4</sub>

## 12.2 Modern Periodic Table

In 1913, the English Physicist Henry Moseley, through his X-ray diffraction experiments, proved that the properties of elements depend on the atomic number and not on the atomic mass. Consequently, the modern periodic table was prepared by arranging elements in the increasing order of their atomic number.

This modern periodic table is the extension of the original Mendeleev's periodic table and known as the long form of periodic table.

### 12.2.1 Modern Periodic Law

Atomic number of an element (Z) indicates the number of protons (positive charge) or the number of electrons (negative charge). The physical and chemical properties of elements depend not only on the number of protons but also on the number of electrons and their arrangements

(electronic configuration) in atoms. Hence, the modern periodic law can be stated as follows: "The chemical and physical properties of the elements are the periodic functions of their atomic numbers". Based on the modern periodic law, the modern periodic table is derived.

### 12.2.2 Features of Modern Periodic Table

- All the elements are arranged in the increasing order of their atomic number.
- The horizontal rows are called periods. There are seven periods in the periodic table.
- The elements are placed in periods based on the number of shells in their atoms.
- Vertical columns in the periodic table starting from top to bottom are called groups. There are 18 groups in the periodic table.
- Based on the physical and chemical properties of elements, they are grouped into various families.

**Table 12.5** Groups in modern periodic table

Group	Families
1	Alkali metals
2	Alkaline earth metals
3 to 12	Transition metals
13	Boron Family
14	Carbon Family
15	Nitrogen Family
16	Oxygen Family (or) Chalcogen Family
17	Halogens
18	Noble gases

### 12.2.3 Classification of elements into blocks

We know that the electrons in an atom are accommodated in shells around the nucleus. Each shell consists of one or more subshells in which the electrons are distributed in certain

# PERIODIC TABLE OF THE ELEMENTS

GROUP	1	2	3	4	5	6	7	8	9	10	11	12	13	14	15	16	17	18
	IA	IIA	IIIB	IVB	VB	VIB	VII B	VIII B	IX	X	IB	IIB	IIIA	IVA	VA	VIA	VIIA	VIIIA
1	<b>H</b> 1.008 HYDROGEN																	<b>He</b> 4.0026 HELIUM
2	<b>Li</b> 6.94 LITHIUM	<b>Be</b> 9.0122 BERYLLIUM											<b>B</b> 10.81 BORON	<b>C</b> 12.011 CARBON	<b>N</b> 14.007 NITROGEN	<b>O</b> 15.999 OXYGEN	<b>F</b> 18.998 FLUORINE	<b>Ne</b> 20.180 NEON
3	<b>Na</b> 22.990 SODIUM	<b>Mg</b> 24.305 MAGNESIUM											<b>Al</b> 26.982 ALUMINIUM	<b>Si</b> 28.085 SILICON	<b>P</b> 30.974 PHOSPHORUS	<b>S</b> 32.06 SULPHUR	<b>Cl</b> 35.45 CHLORINE	<b>Ar</b> 39.948 ARGON
4	<b>K</b> 39.098 POTASSIUM	<b>Ca</b> 40.078 CALCIUM	<b>Sc</b> 44.956 SCANDIUM	<b>Ti</b> 47.867 TITANIUM	<b>V</b> 50.942 VANADIUM	<b>Cr</b> 51.996 CHROMIUM	<b>Mn</b> 54.938 MANGANESE	<b>Fe</b> 55.845 IRON	<b>Co</b> 58.933 COBALT	<b>Ni</b> 58.693 NICKEL	<b>Cu</b> 63.546 COPPER	<b>Zn</b> 65.38 ZINC	<b>Ga</b> 69.723 GALLIUM	<b>Ge</b> 72.64 GERMANIUM	<b>As</b> 74.922 ARSENIC	<b>Se</b> 78.971 SELENIUM	<b>Br</b> 79.904 BROMINE	<b>Kr</b> 83.798 KRYPTON
5	<b>Rb</b> 85.468 RUBIDIUM	<b>Sr</b> 87.62 STRONTIUM	<b>Y</b> 88.906 YTTORIUM	<b>Zr</b> 91.224 ZIRCONIUM	<b>Nb</b> 92.906 NIOBIUM	<b>Mo</b> 95.95 MOLYBDENUM	<b>Tc</b> (98) TECHNETIUM	<b>Ru</b> 101.07 RUTHENIUM	<b>Rh</b> 102.91 RHODIUM	<b>Pd</b> 106.42 PALLADIUM	<b>Ag</b> 107.87 SILVER	<b>Cd</b> 112.41 CADMIUM	<b>In</b> 114.82 INDIUM	<b>Sn</b> 118.71 TIN	<b>Sb</b> 121.76 ANTIMONY	<b>Te</b> 127.60 TELLURIUM	<b>I</b> 126.90 IODINE	<b>Xe</b> 131.29 XENON
6	<b>Cs</b> 132.91 CAESIUM	<b>Ba</b> 137.33 BARIUM	<b>La-Lu</b> 57-71 Lanthanide	<b>Hf</b> 178.49 HAFNIUM	<b>Ta</b> 180.95 TANTALUM	<b>W</b> 183.84 TUNGSTEN	<b>Re</b> 186.21 RHENIUM	<b>Os</b> 190.23 OSMIUM	<b>Ir</b> 192.22 IRIDIUM	<b>Pt</b> 195.08 PLATINUM	<b>Au</b> 196.97 GOLD	<b>Hg</b> 200.59 MERCURY	<b>Tl</b> 204.38 THALLIUM	<b>Pb</b> 207.2 LEAD	<b>Bi</b> 208.98 BISMUTH	<b>Po</b> 209 POLONIUM	<b>At</b> 210 ASTATINE	<b>Rn</b> 222 RADON
7	<b>Fr</b> (223) FRANCIUM	<b>Ra</b> (226) RADIUM	<b>Ac-Lr</b> 89-103 Actinide	<b>Rf</b> 104 RUTHERFORDIUM	<b>Db</b> 105 DUBNIUM	<b>Sg</b> 106 SEABORGIUM	<b>Bh</b> 107 BOHRIIUM	<b>Hs</b> 108 HASSIUM	<b>Mt</b> 109 MEITNERIUM	<b>Ds</b> 110 DARMSTADTIUM	<b>Rg</b> 111 ROENTGENIUM	<b>Cn</b> 112 COPERNICIUM	<b>Nh</b> 113 NIHONIUM	<b>Fl</b> 114 FLEROVIUM	<b>Mc</b> 115 MOSCOVIUM	<b>Lv</b> 116 LIVERMORIUM	<b>Ts</b> 117 TENNESSINE	<b>Og</b> 118 OGANESSON

RELATIVE ATOMIC MASS (1)

GROUP (IUPAC)

GROUP (CAS)

ATOMIC NUMBER

SYMBOL

ELEMENT NAME

Legend:

- Metal
- Semimetal
- Nonmetal
- Alkali metal
- Chalcogens element
- Alkaline earth metal
- Halogens element
- Transition metals
- Noble gas
- Lanthanide
- Actinide

STANDARD STATE (25 °C; 101 kPa)

- Ne - gas
- Hg - liquid
- Fe - solid
- Ts - synthetic

LANTHANIDE

ACTINIDE

57	<b>La</b> 138.91 LANTHANUM	<b>Ce</b> 140.12 CERIUM	<b>Pr</b> 140.91 PRASEODYMIUM	<b>Nd</b> 144.24 NEODYMIUM	<b>Pm</b> (145) PROMETHIUM	<b>Sm</b> 150.36 SAMARIUM	<b>Eu</b> 151.96 EUROPIUM	<b>Gd</b> 157.25 GADOLINIUM	<b>Tb</b> 158.93 TERBIUM	<b>Dy</b> 162.50 DYSPROSIUM	<b>Ho</b> 164.93 HOLMIUM	<b>Er</b> 167.26 ERBIUM	<b>Tm</b> 168.93 THULIUM	<b>Yb</b> 173.05 YTTERIUM	<b>Lu</b> 174.97 LUTETIUM
89	<b>Ac</b> (227) ACTINIUM	<b>Th</b> 232.04 THORIUM	<b>Pa</b> 231.04 PROTACTINIUM	<b>U</b> 238.03 URANIUM	<b>Np</b> (237) NEPTUNIUM	<b>Pu</b> (244) PLUTONIUM	<b>Am</b> (243) AMERICIUM	<b>Cm</b> (247) CURIUM	<b>Bk</b> (247) BERKELIUM	<b>Cf</b> (251) CALIFORNIUM	<b>Es</b> (252) EINSTEINIUM	<b>Fm</b> (257) FERMIUM	<b>Md</b> (258) MENDELEVIUM	<b>No</b> (259) NOBELIUM	<b>Lr</b> (262) LAWRENCIUM



manner. These subshells are designated as s, p, d, and f. Based on the arrangement of electrons in subshells, the elements of periodic table are classified into four blocks namely s, p, d and f blocks.

**(1) s-Block Elements:** It includes group 1 (alkali metals) and group 2 (alkaline earth metals) elements. They are also called as representative elements. The elements of group 1 (except hydrogen) are metals. They react with water to form solutions that change the colour of a litmus paper from red to blue. These solutions are said to be highly alkaline or basic. Hence they are called alkali metals.

The elements of group 2 are also metals. They combine with oxygen to form oxides, formerly called 'earths', and these oxides produce alkaline solutions when they are dissolved in water. Hence, these elements are called alkaline earth metals.

**(2) p-Block Elements:** These elements are in group 13 to 18 in the periodic table. They include boron, carbon, nitrogen, oxygen, fluorine families in addition to noble gases (Except helium). They are also called as representative elements. The p-block is home to the biggest variety of elements and is the only block that contains all three types of elements: metals, nonmetals, and metalloids.

**(3) d-Block Elements:** It includes group 3 to group 12 elements. They are found in the centre of the periodic table. Their properties are intermediate to that of s block and p block elements and so they are called transition elements.

**(4) f - Block Elements:** It includes 14 elements after (Lanthanum) La (57), called Lanthanoides and 14 elements after (Actinium) Ac (89), called Actinoides. They are placed at the bottom of the periodic table. They are also called as inner Transition elements.

#### 12.2.4 Advantages of the Modern Periodic Table

- The table is based on a more fundamental property i.e., atomic number.
- It correlates the position of the element with its electronic configuration more clearly.
- The completion of each period is more logical. In a period, as the atomic number increases, the energy shells are gradually filled up until an inert gas configuration is reached.
- It is easy to remember and reproduce.
- Each group is an independent group and the idea of subgroups has been discarded.
- One position for all isotopes of an element is justified, since the isotopes have the same atomic number.
- The position of the eighth group (in Mendeleev's table) is also justified in this table. All transition elements have been brought in the middle as the properties of transition elements are intermediate between left portion and right portion elements of the periodic table.
- The table completely separates metals from nonmetals. The nonmetals are present in upper right corners of the periodic table.
- The positions of certain elements which were earlier misfit (interchanged) in the Mendeleev's periodic table are now justified because it is based on atomic number of the elements.
- Justification has been offered for placing lanthanides and actinides at the bottom of the periodic table.

#### 12.2.5 Position of hydrogen in the periodic table

Hydrogen is the lightest, smallest and first element of the periodic table. Its electronic configuration ( $1s^1$ ) is the simplest of all the elements. It occupies a unique position in the periodic table. It behaves like alkali metals as well as halogens in its properties.

**Table 12.6** Number of electrons in subshell

Shell number (Symbol)	1 (K)		2 (L)			3 (M)			4 (N)	
Sub shell	1s	2s	2p	3s	3p	3d	4s	4p	4d	4f
Maximum number of electrons in each sub shell	2	2	6	2	6	10	2	6	10	14
Maximum number of electrons in each shell	2		8			18			32	

In the periodic table, it is placed at the top of the alkali metals.

- (i) Hydrogen can lose its only one electron to form a hydrogen ion ( $H^+$ ) like alkali metals.
- (ii) It can also gain one electron to form the hydride ion ( $H^-$ ) like halogens.
- (iii) Alkali metals are solids while hydrogen is a gas.

Hence the position of hydrogen in the modern periodic table is still under debate as the properties of hydrogen are unique.

### 12.2.6. Position of Rare Gases

The elements Helium, Neon, Argon, Krypton, Xenon and Radon of group 18 in the periodic table are called as Noble gases or Rare gases. They are monoatomic gases and do not react with other substances easily, due to completely filled subshells. Hence they are called as inert gases. They are found in very small quantities and hence they are called as rare gases.

## 12.3 Metals, Non-Metals and Metalloids

### 12.3.1 Metals

Metals are typically hard, shiny, malleable (can be made as sheet), fusible and ductile (can be drawn into wire) with good electrical and thermal conductivity. Except mercury, most of the metals are solids at room temperature. Metals occupy larger area in the periodic table and are categorized as:

- (i) Alkali metals. e.g. Lithium to Francium (top to bottom)
- (ii) Alkaline earth metals. e.g: Beryllium to Radium (top to bottom)
- (iii) Transition Metals. Group 3 to 12
- (iv) p-block metals. e.g: Al, Ga, In, Tl, Sn, Pb and Bi.

### 4.3.2. Non-metals

A non-metal is an element that does not have the characters like hardness, shiny, malleable, suitable and ductile. In other words, a non-metal is an element that does not have the properties of metal. All non metals are arranged in p-block only. E.g. C, N, O, P, S, Se, Halogen (F, Cl, Br and I) and inert gases (He to Rn).

### 12.3.3 Metalloids

Elements which have the properties of both metals and non-metals are called as metalloids. (eg) Boron, Arsenic.

## 12.4 Alloys

During 3500 BC(BCE), people used an alloy named 'bronze'. The idea of making an alloy was quite old. The majority of the metallic substances used today are alloys. Alloys are mixtures of two or more metals and are formed by mixing molten metals thoroughly. Rarely nonmetals are also mixed with metals to produce alloys.



It is generally found that alloying produces a metallic substance that has more useful properties than the original pure metals from which it is made. For example, the alloy brass is made from copper and zinc.

### 12.4.1 Advantages of alloys

- Alloys do not get corroded or get corroded to very less extent.
- They are harder and stronger than pure metals (Example: Gold is mixed with copper and it is harder than pure gold).
- They have less conductance than pure metals (Example: Copper is good conductor of heat and electricity where as brass and bronze are not good conductors).
- Some alloys have lower melting point than pure metals (Example: Solder is an alloy of lead and tin which has lower melting point than each of the metals).
- When metal is alloyed with mercury, it is called amalgam.

### Points to Remember

- ❖ Dobereiner grouped the elements based on their relative atomic masses in a group of three (triads).
- ❖ John Newlands arranged 56 known elements in the increasing order of their atomic mass.
- ❖ Dmitri Mendeleev proposed the law of periodicity.
- ❖ Mendeleev's Periodic Table has eight vertical columns called 'groups' and seven horizontal rows called 'period'.
- ❖ In the modern periodic table all the elements are arranged in the increasing order of their atomic number.
- ❖ There are seven periods and 18 groups in the modern periodic table.
- ❖ The elements are placed in periods based on the number of shells in their atoms.
- ❖ Based on the common characteristics of elements in each group, they are grouped as various families.

## A-Z GLOSSARY

<b>Dobereiner's Law of Triads</b>	The atomic mass of the middle element is nearly the same as average of atomic masses of other two elements.
<b>Newlands' Law of Octaves</b>	Every eighth element had properties similar to those of the first element like the eighth note in an octave of music is similar to the first.
<b>Mendeleev's Law of Periodicity</b>	The physical and chemical properties of the elements are the periodic functions of their atomic masses.
<b>Modern Periodic Law</b>	The chemical and physical properties of the elements are the periodic functions of their atomic numbers.
<b>Periods</b>	Horizontal rows in the modern periodic table.
<b>Columns</b>	Vertical columns in the modern periodic table
<b>s block elements</b>	Elements whose valence electrons are added to s subshell.
<b>p block elements</b>	Elements whose valence electrons are filled in p subshells.
<b>d block elements</b>	Elements having their valence electrons in the d subshells.
<b>f block elements</b>	Elements having their valence electrons in the f subshells.



## TEXTBOOK EXERCISES



### I. Choose the correct answer.

- If Dobereiner is related with 'law of triads', then Newlands is related with
  - Modern periodic law
  - Hund's rule
  - Law of octaves
  - Pauli's Exclusion principle
- Modern periodic law states that the physical and chemical properties of elements are the periodic functions of their \_\_\_\_\_
  - atomic numbers
  - atomic masses
  - similarities
  - anomalies
- Elements in the modern periodic table are arranged in \_\_\_\_\_ groups and \_\_\_\_\_ periods.
  - 7, 18
  - 18, 7
  - 17, 8
  - 8, 17
- Metals can gain electrons.
- Alloys bear the characteristics of both metals and nonmetals.
- Lanthanides and actinides are kept at the bottom of the periodic table because they resemble each other but they do not resemble with any other group elements.
- Group 17 elements are named as Halogens.

### II. Fill in the blanks.

- In Dobereiner's triads, the atomic weight of the middle element is the \_\_\_\_\_ of the atomic masses of 1st and 3rd elements.
- Noble gases belong to \_\_\_\_\_ group of the periodic table.
- The basis of the classifications proposed by Dobereiner, Newlands and Mendeleev was \_\_\_\_\_.
- Example for liquid metal is \_\_\_\_\_.

### III. Match the following.

Triads	Newlands
Alkali metal	Calcium
Law of octaves	Henry Moseley
Alkaline earth metal	Sodium
Modern Periodic Law	Dobereiner

### IV. State whether true or false. If false, correct the statement.

- Newlands' periodic table is based on atomic masses of elements and modern periodic table is based on atomic number of elements.

### V. Assertion and reason type questions.

Statement: Elements in a group generally possess similar properties but elements along a period have different properties.

Reason: The difference in electronic configuration makes the element differ in their chemical properties along a period.

- Statement is true and reason explains the statement.
- Statement is false but the reason is correct.

### VI. Answer the following.

- State modern periodic law.
- What are groups and periods in the modern periodic table?
- What are the limitations of Mendeleev's periodic table?
- State any five features of modern periodic table.



## REFERENCE BOOKS

- CONCISE Inorganic chemistry : 5th Edition by J.D. Lee
- Inorganic Chemistry by P.L.Soni
- The Periodic table: Its story and its significance: Eric R. Scerri



## INTERNET RESOURCES

1. <https://www.ptable.com/>
2. <https://iupac.org/what-we-do/periodic-table-of-elements/>
3. [www.rsc.org/periodic-table](http://www.rsc.org/periodic-table)
4. <https://sciencestruck.com/periodic-table-facts>
5. <https://ww.teachbeside.com/memorize-periodictable>

## Concept Map

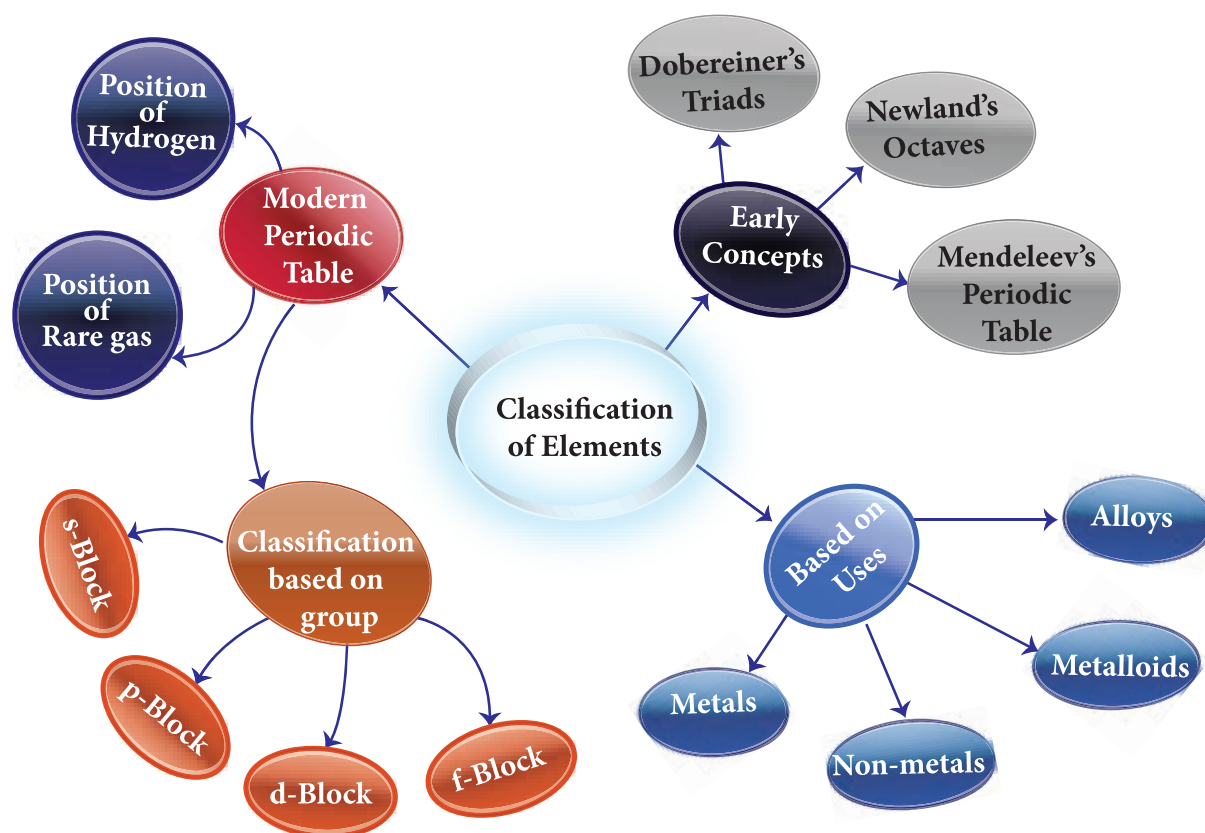

## ICT CORNER

## Periodic Classification

### Steps

1. Type the URL link given below in the browser OR scan the QR code. You can also download the “**Royal society of chemistry**” mobile app from the given app URL.
2. Click the element from the table and explore the properties of the element you want to learn.
3. On the right top corner click option as shown to learn the uses and properties.
4. For every element we can understand the uses and the properties of elements.



B567\_9\_SCI\_EM\_T3

URL: <https://play.google.com/store/apps/details?id=org.rsc.periodictable> or Scan the QR Code.

## Learning Objectives

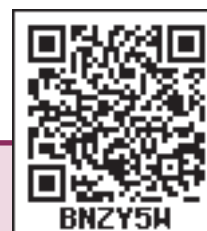

After completing this lesson, student will be able to

- understand how molecules are formed and what is a chemical bond.
- explain Octet rule.
- draw Lewis dot structure of atoms.
- understand different types of bonds.
- differentiate the characteristics of ionic bond, covalent bond and coordinate bond.
- understand redox reactions.
- find out the oxidation number of different elements.

## Introduction

We already know that atoms are the building blocks of matter. Under normal conditions no atom exists as an independent (single) entity in nature, except noble gases. However, a group of atoms is found to exist together as one species. Such a group of atoms is called molecule. Obviously there should be a force to keep the constituent atoms together as the thread holds the flowers together in a garland. This attractive force which holds the atoms together is called a bond.



**Figure. 13.1** Flowers held together by thread

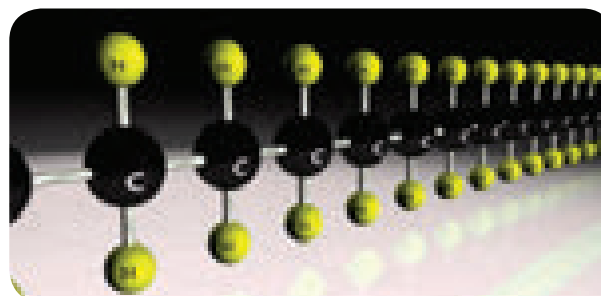

**Figure. 13.2** Atoms held together by bond

A chemical bond may be defined as the force of attraction between the atoms that binds them together as a unit called molecule. In this unit, we will study about Kossel-Lewis approach to chemical bonds, Lewis dot structure and different types of reactions.

### 13.1 Kossel – Lewis approach to chemical bonds

#### 13.1.1 Octet rule

Atoms of various elements combine together in different ways to form chemical compounds. This phenomenon raised many questions.



- Why do atoms combine?
- How do atoms combine?
- Why do certain atoms combine while others do not?

To answer such questions different theories have been put forth from time to time and one of such theories which explained the formation of molecules is Kossel-Lewis theory.

Kossel and Lewis gave successful explanation based upon the concept of electronic configuration of noble gases about why atoms combine to form molecules. Atoms of noble gases have little or no tendency to combine with each other or with atoms of other elements. This means that these atoms must be having stable electronic configurations. The electronic configurations of noble gases are given in Table 13.1.

**Table 13.1** The electronic configurations of noble gases

Name of the element	Atomic number	Shell electronic configuration
Helium (He)	2	2
Neon (Ne)	10	2,8
Argon (Ar)	18	2,8,8
Krypton (Kr)	36	2,8,18,8
Xenon (Xe)	54	2,8,18,18,8
Radon (Rn)	86	2,8,18,32,18,8

Except Helium, all other noble gases have eight electrons in their valence shell. Even helium has its valence shell completely filled and hence no more electrons can be added. Thus, by having stable valence shell electronic configuration, the noble gas atoms neither have any tendency to gain nor to lose electrons and hence their valency is zero. They are so inert that they even do not form diatomic molecules and exist as monoatomic gaseous atoms.

### More to Know

The number of electrons lost from a metal atom is the valency of the metal and the number of electrons gained by a non-metal is the valency of the non-metal

Based on the noble gas electronic configuration, Kossel and Lewis proposed a theory in 1916 to explain chemical combination between atoms and this theory is known as 'Electronic theory of valence' or Octet rule. According to this, atoms of all elements, other than inert gases, combine to form molecules because they have incomplete valence shell and tend to attain a stable electronic configuration similar to noble gases. Atoms can combine either by transfer of valence electrons from one atom to another or by sharing of valence electrons in order to achieve the stable outer shell of eight electrons.

The tendency of atoms to have eight electrons in the valence shell is known as the 'Octet rule' or the 'Rule of eight'

For example, sodium with atomic number 11 will readily lose one electron to attain neon's stable electronic configuration (Figure 13.3). Similarly, chlorine has electronic configuration 2,8,7. To get the nearest noble gas (i.e. argon) configuration, it needs one more electron. So, chlorine readily gains one electron from other atom and obtains stable electronic configuration (Figure 13.4). Thus elements tend to have stable valence shell (eight electrons) either by losing or gaining electrons.

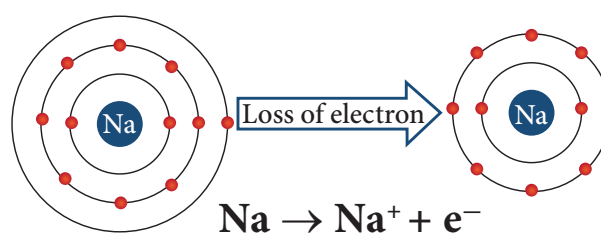

**Figure. 13.3** Formation of sodium ion

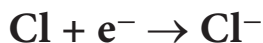
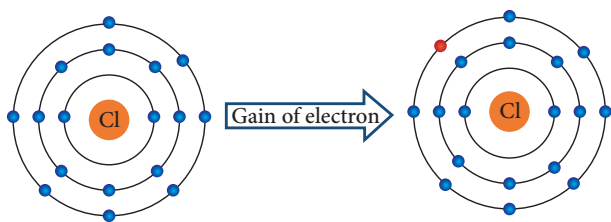

**Figure 5.4** Formation of chloride ion

Which atoms tend to lose electrons? Which are tend to gain electrons? Atoms that have 1, 2, 3 electrons in their valence shell tend to lose electrons whereas atoms having 5, 6, 7 valence electrons tend to gain electrons.

**Table 13.2** Unstable electronic configuration

Element	Atomic number	Electron distribution	Valence electrons
Boron	5	2, 3	3
Nitrogen	7	2, 5	5
Oxygen	8	2,6	6
Sodium	11	2, 8, 1	1

## 13.2 Lewis dot structure

When atoms combine to form compounds, their valence electrons involve in bonding. Therefore, it is helpful to have a method to depict the valence electrons in the atoms. This can be done using Lewis dot symbol method. The Lewis dot structure or electron dot symbol for an atom consists of the symbol of the element surrounded by dots representing the electrons of the valence shell of the atom. The unpaired electron in the valence shell is represented by a single dot whereas the paired electrons are represented by a pair of dots.

Symbols other than dots, like crosses or circles may be used to differentiate the electrons of the different atoms in the molecule.

**Table 13.3** Lewis dot structure

Element	Atomic number	Electron distribution	Valence electrons	Lewis dot structure
Hydrogen	1	1	1	H•
Helium	2	2	2	He:
Beryllium	4	2, 2	2	•Be•
Carbon	6	2, 4	4	•C•
Nitrogen	7	2, 5	5	•N•
Oxygen	8	2,6	6	•O•

### More to Know

Note that dots are placed one to each side of the letter symbol until all four sides are occupied. Then the dots are written two to a side until all valence electrons are accounted for. The exact placement of the single dots is immaterial.

## 13.3 Types of chemical bond

All the elements have different valence shell electronic configuration. So the way in which they combine to form compounds also differs. Hence, there are



different types of chemical bonding possible between atoms which make the molecules. Depending on the type of bond, they show different characteristics or properties. Such types of bonding, that are considered to exist in molecules, are categorized as shown Figure 13.5. Among these, let us learn about the Ionic bond, Covalent bond and Coordinate bond in this chapter and other types of bond in the higher classes.

### 13.3.1 Ionic (or) Electrovalent bond

An ionic bond is a chemical bond formed by the electrostatic attraction between

positive and negative ions. The bond is formed between two atoms when one or more electrons are transferred from the valence shell of one atom to the valence shell of the other atom. The atom that loses electrons will form a cation (positive ion) and the atom that gains electrons will form an anion (negative ion). These oppositely charged ions come closer to each other due to electrostatic force of attraction and thus form an ionic bond. As the bond is between the ions, it is called ***Ionic bond*** and the attractive forces being electrostatic, the bond is also called ***Electrostatic bond***. Since the valence concept has been explained in terms of electrons, it is also called as ***Electrovalent bond***.

### Formation of ionic bond

Let us consider two atoms A and B. Let atom A has one electron in excess and atom B has one electron lesser than the stable octet electronic configuration. If atom A transfer one electron to atom B, then both the atoms will acquire stable octet electronic configuration. As the result of this electron transfer, atom A will become positive ion (cation) and atom B will become negative ion (anion). These oppositely charged ions are held together by electrostatic force of attraction which is called ***Ionic bond*** or ***Electrovalent bond***.

In general, ionic bond is formed between a metal and non-metal. The compounds

containing ionic bonds are called ionic compounds. Elements of Group 1 and 2 in periodic table, i.e. alkali and alkaline earth metals form ionic compounds when they react with non-metals.

### More to Know

The number of electrons that an atom of an element loses or gains to form an electrovalent bond is called its **Electrovalency**.

### Illustration 1 – Formation of ionic bonding in sodium chloride (NaCl)

The atomic number of Sodium is 11 and its electronic configuration is 2, 8, 1. It has one electron excess to the nearest stable electronic configuration of a noble gas - Neon. So sodium has a tendency to lose one electron from its outermost shell and acquire a stable electronic configuration forming sodium cation ( $\text{Na}^+$ ).

The atomic number of chlorine is 17 and its electronic configuration is 2, 8, 7. It has one electron less to the nearest stable electronic configuration of a noble gas - Argon. So chlorine has a tendency to gain one electron to acquire a stable electronic configuration forming chloride anion ( $\text{Cl}^-$ ).

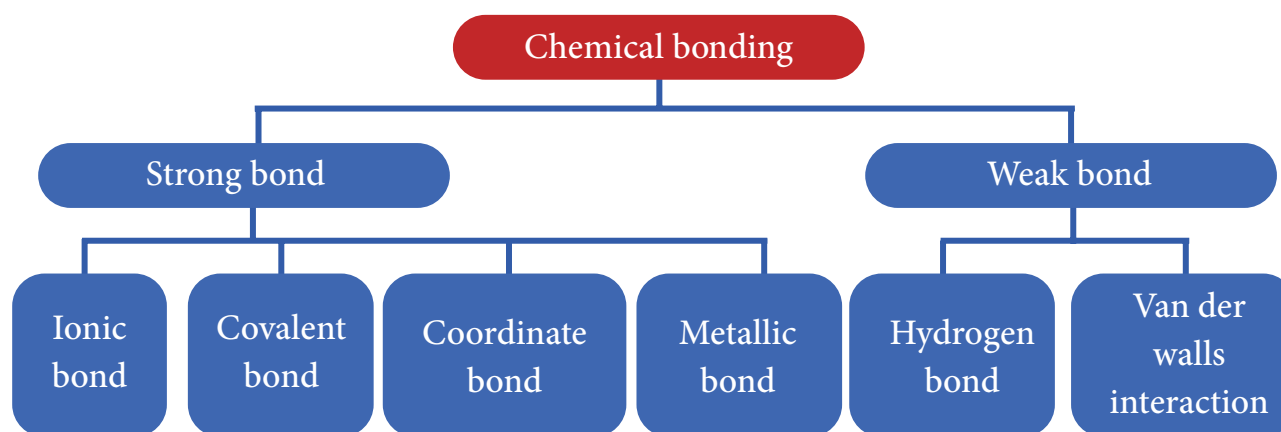
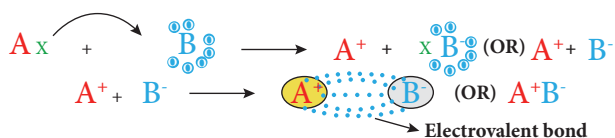
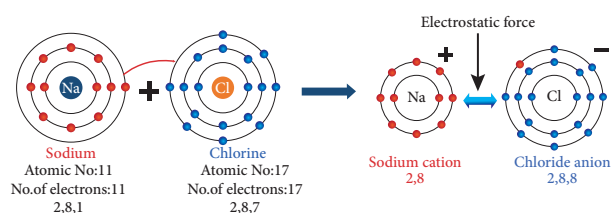

Figure. 13.5 Classification of chemical bond



When an atom of sodium combines with an atom of chlorine, an electron is transferred from sodium atom to chlorine atom forming sodium chloride molecule thus both the atoms attain stable octet electronic configuration.



**Figure. 13.6** Formation of ionic bond in sodium chloride

### Illustration 2 – Formation of ionic bond in magnesium chloride ( $MgCl_2$ )

The atomic number of magnesium is 12 and the electronic configuration is 2, 8, 2. It has two electron excess to the nearest stable electronic configuration of a noble gas - Neon. So magnesium has a tendency to lose two electrons from its outermost shell and acquire a stable electronic configuration forming magnesium cation ( $Mg^{2+}$ ).

As explained earlier two chlorine atoms will gain two electrons lost by the magnesium atom forming magnesium chloride molecule ( $MgCl_2$ ) as shown in Figure 13.7.

### Characteristics of Ionic compounds

The nature of bonding between the atoms of a molecule is the primary factor that

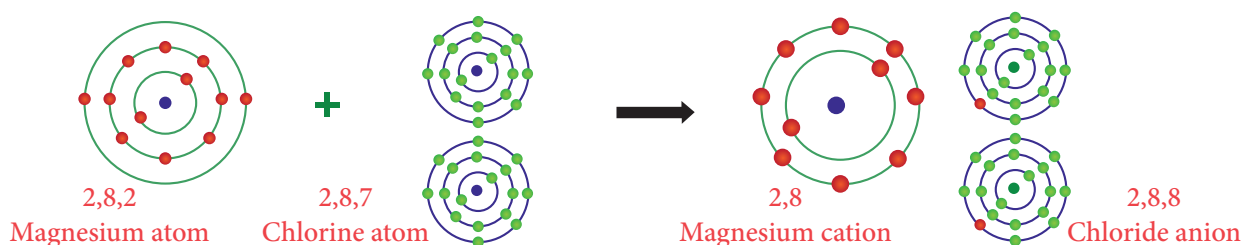

**Figure. 13.7** Formation of ionic bond in magnesium chloride

determines the properties of compounds. By this way, in ionic compounds the atoms are held together by a strong electrostatic force that makes the compounds to have its characteristic features as follows:

**Physical state:** These compounds are formed because of the strong electrostatic force between cations and anions which are arranged in a well-defined geometrical pattern. Thus ionic compounds are crystalline solids at room temperature.

**Electrical conductivity:** Ionic compounds are crystalline solids and so their ions are tightly held together. The ions, therefore, cannot move freely, and they do not conduct electricity in solid state. However, in molten state their aqueous solutions conduct electricity.

**Melting point:** The strong electrostatic force between the cations and anions hold the ions tightly together, so very high energy is required to separate them. Hence ionic compounds have high melting and boiling points.

**Solubility:** Ionic compounds are soluble in polar solvents like water. They are insoluble in non-polar solvents like benzene ( $C_6H_6$ ), carbon tetra chloride ( $CCl_4$ ).

**Density, hardness and brittleness:** Ionic compounds have high density and they are quite hard because of the strong electrostatic force between the ions. But they are highly brittle.

**Reactions:** Ionic compounds undergo ionic reactions which are practically rapid and instantaneous.

### 13.3.2 Covalent bond

Atoms can combine with each other by sharing the unpaired electrons in their outermost shell. Each of the two combining atoms contributes one electron to the electron pair which is needed for the bond formation and has equal claim on the shared electron pair. According to Lewis concept, when two atoms form a covalent bond between them, each of the atoms attains the stable electronic configuration of the nearest noble gas. Since the covalent bond is formed because of the sharing of electrons which become common to both the atoms, it is also called as *atomic bond*.

#### Formation of Covalent bond

Let us consider two atoms A and B. Let atom A has one valence electron and atom B has seven valence electrons. As these atoms approach nearer to each other, each atom contributes one electron and the resulting electron pair fills the outer shell of both the atoms. Thus both the atoms acquire a completely filled valence shell electronic configuration which leads to stability.

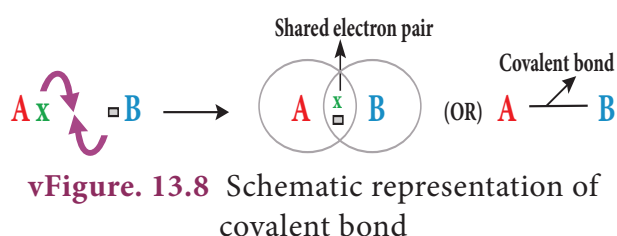

#### More to Know

Covalent bonds are of three types:

1. Single covalent bond represented by a line (—) between the two atoms. Eg. H—H
2. Double covalent bond represented by a double line (=) between the two atoms. Eg. O=O
3. Triple covalent bond represented by a triple line ( $\equiv$ ) between the two atoms. Eg. N $\equiv$ N

#### Illustration 1 – Formation of hydrogen molecule (H<sub>2</sub>)

Hydrogen molecule is formed by two hydrogen atoms. While forming the molecule, both hydrogen atoms contribute one electron each to the shared pair and both atoms acquire stable and completely filled electronic configuration (resemble He).

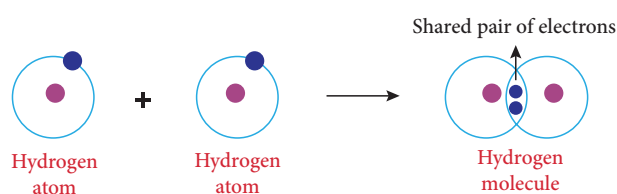

#### Illustration 2 – Formation of chlorine molecule (Cl<sub>2</sub>)

Chlorine molecule is formed by two chlorine atoms. Each chlorine atom has seven valence electrons (2,8,7). These two atoms achieve a stable completely filled electronic configuration (octet) by sharing a pair of electrons.

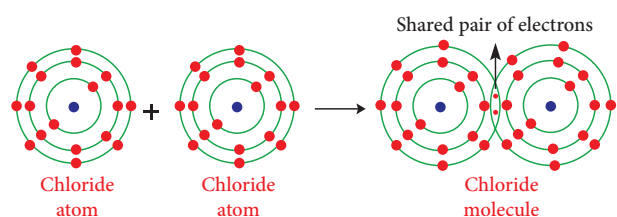

#### Illustration 3 – Formation of methane molecule (CH<sub>4</sub>)

Methane molecule is formed by the combination of one carbon and four hydrogen atoms. The carbon atom has four valence electrons (2, 4). These four electrons are shared with four atoms of hydrogen to achieve a stable electronic configuration (octet) by sharing a pair of electrons.

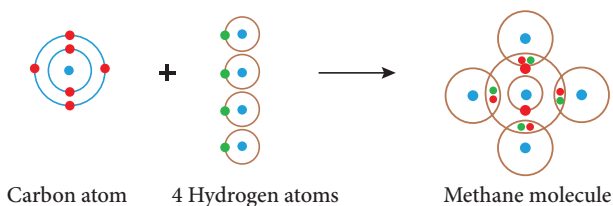

**Figure. 13.11** Formation of covalent bond in methane molecule

#### Illustration 4 – Formation of oxygen molecule ( $O_2$ )

Oxygen molecule is formed by two oxygen atoms. Each oxygen atom has six valence electrons (2, 6). These two atoms achieve a stable electronic configuration (octet) by sharing two pair of electrons. Hence a double bond is formed in between the two atoms.

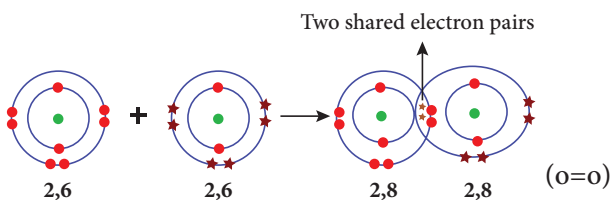

**Figure. 13.12** Formation of covalent bond in oxygen molecule

#### Illustration 5 – Formation of nitrogen molecule ( $N_2$ )

Nitrogen molecule is formed by two nitrogen atoms. Each nitrogen atom has five valence electrons (2, 5). These two atoms achieve a stable completely filled electronic configuration (octet) by sharing three pair of electrons. Hence a triple bond is formed in between the two atoms.

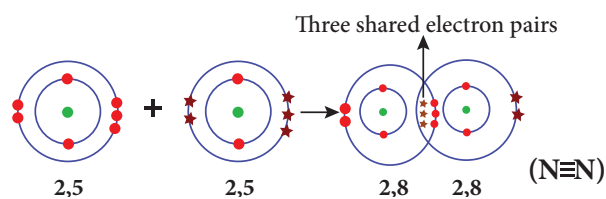

**Figure. 13.13** Formation of covalent bond in nitrogen molecule

#### Characteristics of Covalent compounds

As said earlier, the properties of compounds depend on the nature of bonding between their

constituent atoms. So the compounds containing covalent bonds possess different characteristics when compared to ionic compounds.

**Physical state:** Depending on force of attraction between covalent molecule the bond may be weaker or stronger. Thus covalent compounds exists in gaseous, liquid and solid form. Eg. Oxygen-gas; Water-liquid; Diamond-solid.

**Electrical conductivity:** Covalent compounds do not contain charged particles (ions), so they are bad conductors of electricity.

**Melting point:** Except few covalent compounds (Diamond, Silicon carbide), they have relatively low melting points compared to ionic compounds.

**Solubility:** Covalent compounds are readily soluble in non-polar solvents like benzene ( $C_6H_6$ ), carbon tetra chloride ( $CCl_4$ ). They are insoluble in polar solvents like water.

**Hardness and brittleness:** Covalent compounds are neither hard nor brittle. But they are soft and waxy.

**Reactions:** Covalent compounds undergo molecular reactions in solutions and these reactions are slow.

#### More to Know

Polar solvents contain bonds between atoms with very different electronegativities, such as oxygen and hydrogen. Ionic compounds are soluble in polar solvents. Ex: water, ethanol, acetic acid, ammonia

Non polar solvents contain bonds between atoms with similar electro negativities, such as carbon and hydrogen. Covalent compounds are soluble in non-polar solvents. Ex: acetone, benzene, toluene, turpentine

#### Fajan's Rule:

As we know, a metal combines with a non-metal through ionic bond. The compounds

so formed are called ionic compounds. A compound is said to be ionic when the charge of the cation and anion are completely separated. But in 1923, Kazimierz Fajans found, through his X-Ray crystallographic studies, that some of the ionic compounds show covalent character. Based on this, he formulated a set of rules to predict whether a chemical bond is ionic or covalent. Fajan's rules are formulated by considering the charge of the cation and the relative size of the cation and anion.

- When the size of the cation is small and that of anion is large, the bond is of more covalent character
- Greater the charge of the cation, greater will be the covalent character

Ionic	Covalent
Low positive charge	High positive charge
Large cation	Small cation
Small anion	Large anion

For example, in sodium chloride, low positive charge (+1), a fairly large cation and relatively small anion make the charges to separate completely. So it is ionic. In aluminium triiodide, higher is the positive charge (+3), larger is the anion and thus no complete charge separation. So is covalent. The following picture depicts the relative charge separation of ionic compounds:

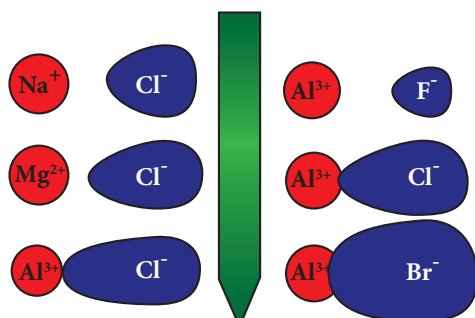

**Figure. 13.14** Relative charge separation of ionic compounds

### 13.3.3 Coordinate covalent bond

In the formation of normal covalent bond each of the two bonded atoms contribute one electron to form the bond. However, in some compounds, the formation of a covalent bond between two atoms takes place by the sharing of two electrons, both of which comes from only one of the combining atoms. This bond is called **Coordinate covalent bond or Dative bond**.

Mostly the lone pair of electrons from an atom in a molecule may be involved in the dative bonding. The atom which provides the electron pair is called **donor atom** while the other atom which accepts the electron pair is called **acceptor atom**. The coordinate covalent bond is represented by an arrow ( $\rightarrow$ ) which points from the donor to the acceptor atom.

#### Formation of coordinate covalent bond

Let us consider two atoms A and B. Let atom A has an unshared lone pair of electrons and atom B is in short of two electrons than the octet in its valence shell. Now atom A donates its lone pair while atom B accepts it. Thus the lone pair of electrons originally belonged to atom A are now shared by both the atoms and the bond formed by this mutual sharing is called Coordinate covalent bond. ( $A \rightarrow B$ )

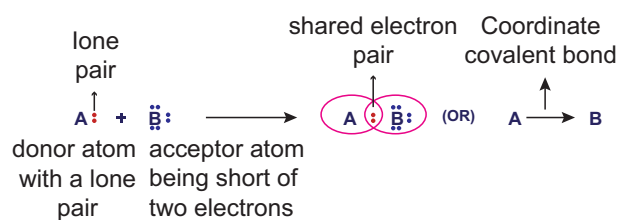

Examples ( $\text{NH}_4^+$ ,  $\text{NH}_3 \rightarrow \text{BF}_3$ )

#### Illustration 1 – Formation of coordinate covalent bond between $\text{NH}_3 \rightarrow \text{BF}_3$ molecules

In some cases, the donated pair of electrons comes from a molecule as a whole which is already formed to another acceptor

molecule. Here the molecule ammonia ( $\text{NH}_3$ ) gives a lone pair of electrons to Boron tri fluoride ( $\text{BF}_3$ ) molecule which is electron deficient. Thus, a coordinate covalent bond is formed between  $\text{NH}_3$  (donor molecule) and  $\text{BF}_3$  (acceptor molecule) and is represented by  $\text{NH}_3 \rightarrow \text{BF}_3$ .

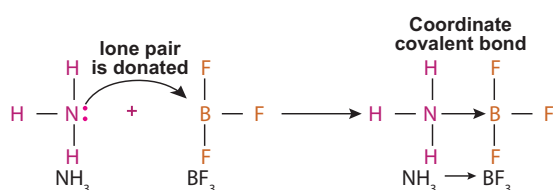

### Characteristics of coordinate covalent compounds

The compounds containing coordinate covalent bonds are called coordinate compounds.

**Physical state:** These compounds exist as gases, liquids or solids.

**Electrical conductivity:** Like covalent compounds, coordinate compounds also do not contain charged particles (ions), so they are bad conductors of electricity.

**Melting point:** These compounds have melting and boiling points higher than those of purely covalent compounds but lower than those of purely ionic compounds.

**Solubility:** Insoluble in polar solvents like water but are soluble in non-polar solvents like benzene,  $\text{CCl}_4$ , and toluene.

**Reactions:** Coordinate covalent compounds undergo molecular reactions which are slow.

## 13.4 Oxidation, Reduction and Redox reactions

When an apple is cut and left for sometimes, its surface turns brown. Similarly, iron bolts and nuts in metallic structures get rusted. Do you know why these are happening? It is because of a reaction called oxidation.



**Oxidation:** The chemical reaction which involves addition of oxygen or removal of hydrogen or loss of electrons is called oxidation.

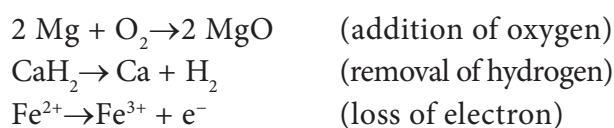

**Reduction:** The chemical reaction which involves addition of hydrogen or removal of oxygen or gain of electrons is called reduction.

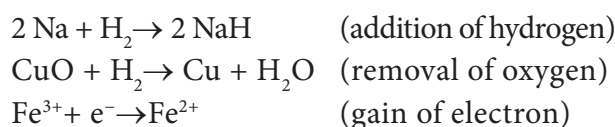

**Redox reactions:** Generally, the oxidation and reduction occurs in the same reaction (simultaneously). If one reactant gets oxidised, the other gets reduced. Such reactions are called oxidation-reduction reactions or Redox reactions.

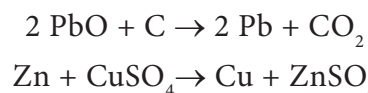

Oxidation	Addition of oxygen
	Removal of hydrogen
	Loss of electron
Reduction	Removal of oxygen
	Addition of hydrogen
	Gain of electron

### Oxidising agents and Reducing agents

Substances which have the ability to oxidise other substances are called oxidising agents.



These are also called as electron acceptors because they remove electrons from other substances.

Example:  $\text{H}_2\text{O}_2$ ,  $\text{MnO}_4^-$ ,  $\text{CrO}_3$ ,  $\text{Cr}_2\text{O}_7^{2-}$

Substances which have the ability to reduce other substances are called Reducing agents. These are also called as electron donors because they donate electrons to other substances.

Example:  $\text{NaBH}_4$ ,  $\text{LiAlH}_4$  and metals like Palladium, Platinum.

### Oxidation reactions in daily life:

In nature, the oxygen present in atmospheric air oxidises many things, starting from metals to living tissues.

- The shining surface of metals tarnishes due to the formation of respective metal oxides on their surfaces. This is called corrosion.
- The freshly cut surfaces of vegetables and fruits turn brown after some time because of the oxidation of compounds present in them.
- The oxidation reaction in food materials that were left open for a long period is responsible for spoiling of food. This is called Rancidity.

### Oxidation number

Oxidation number of an element is defined as the total number of electrons that an atom either gains or loses in order to form a chemical bond with another atom. Oxidation number is also called oxidation state. If the oxidation number is positive then it means that the atom loses electron, and if it is negative it means that the atom gains electrons. If it is zero then the atom neither gains nor loses electrons. The sum of oxidation numbers of all the atoms in the formula for a neutral compound is ZERO. The sum of oxidation numbers of an ion is the same as the charge on that ion. Negative oxidation number in a compound of two unlike atoms is assigned to the more electronegative atom.

### More to Know

Electronegativity is the tendency of an atom in a molecule to attract towards itself the shared pair of electrons.

Example:

- Oxidation number of K and Br in KBr molecule is +1 and -1 respectively.
- Oxidation number of N in  $\text{NH}_3$  molecule is -3.
- Oxidation number of H is +1 (except hydrides).
- Oxidation number of oxygen in most cases is -2.

### Problems on determination of Oxidation Number

ON (Oxidation Number) of neutral molecule is always zero

#### Illustration 1

#### Oxidation Number of H and O in $\text{H}_2\text{O}$

Let us take ON of H = +1 and ON of O = -2

$$2 \times (+1) + 1 \times (-2) = 0$$

$$(+2) + (-2) = 0$$

Thus, ON of H is +1 and ON of O is -2

#### Illustration 2

#### Oxidation Number of S in $\text{H}_2\text{SO}_4$

Let ON of S be x and we know ON of H = +1 and O = -2

$$2 \times (+1) + x + 4 \times (-2) = 0$$

$$(+2) + x + (-8) = 0$$

$$x = +6 \quad \text{Therefore, ON of S is +6}$$

#### Illustration 3

#### Oxidation Number of Cr in $\text{K}_2\text{Cr}_2\text{O}_7$

Let ON of Cr be x and we know ON of K = +1 and O = -2

$$2 \times (+1) + 2 \times x + 7 \times (-2) = 0$$

$$(+2) + 2x + (-14) = 0$$

$$2x = +12$$

$$x = +6 \quad \text{Therefore, ON of Cr in } \text{K}_2\text{Cr}_2\text{O}_7 \text{ is +6}$$

#### Illustration 4

#### Oxidation Number of Fe in $\text{FeSO}_4$

Let ON of Fe be x and we know ON of S = +6 and O = -2

$$x + 1 \times (+6) + 4 \times (-2) = 0$$

$$x + (+6) + (-8) = 0$$

$$x = +2 \text{ Therefore, ON of Fe in FeSO}_4 \text{ is } +2$$

### Problems:

1. Find the oxidation number of Mn in  $\text{KMnO}_4$
2. Find the oxidation number of Cr in  $\text{Na}_2\text{Cr}_2\text{O}_7$
3. Find the oxidation number of Cu in  $\text{CuSO}_4$
4. Find the oxidation number of Fe in  $\text{FeO}$

### Points to Remember

- ❖ The tendency of atoms to have eight electrons in the valence shell is known as the 'Octet rule' or the 'Rule of eight'.
- ❖ The Lewis dot structure or electron dot symbol for an atom consists of the symbol of the element surrounded by dots representing the electrons of the valence shell of the atom.
- ❖ There are different types of chemical bonding possible between atoms which make the molecules. Depending on the type of bond they show different characteristics or properties.
- ❖ An ionic bond is formed by the electrostatic attraction between positive and negative ions. It is also called as Electrochemical bond.
- ❖ The covalent bond is formed because of the sharing of electrons which become common to both the atoms. It is also called as Atomic bond.
- ❖ In some compounds the formation of a covalent bond between two atoms takes place by the sharing of two electrons, both of which comes from only one of the combining atoms. This bond is called Coordinate covalent bond or Dative bond.
- ❖ Substances which have the ability to oxidise other substances are called Oxidising agents. These are also called as electron acceptors because they remove electrons from other substances.
- ❖ Substances which have the ability to reduce other substances are called Reducing agents. These are also called as electron donors because they donate electrons to other substances.
- ❖ Oxidation number also called Oxidation State.

## A-Z GLOSSARY

<b>Chemical bond</b>	Force of attraction between the two atoms that binds them together as a unit.
<b>Coordinate covalent bond</b>	Bond formed between atoms by mutual sharing of electrons which are supplied by one atom.
<b>Covalent bond</b>	Bond formed between atoms by the mutual sharing of electrons.
<b>Ionic / Electrovalent bond</b>	Bond formed between cation and anion because of the transfer of electrons from one atom to other atom.
<b>Octet rule or Rule of eight</b>	The tendency of atoms to have eight electrons in the valence shell.
<b>Oxidation</b>	Chemical reaction which involves in the addition of oxygen or removal of hydrogen or loss of electrons.
<b>Oxidation number</b>	The formal charge which an atom has when electrons are counted.
<b>Oxidising agents</b>	Substances which have the ability to oxidise other substances.
<b>Redox reaction</b>	Oxidation and reduction occurs in the same reaction simultaneously.
<b>Reducing agents</b>	Substances which have the ability to reduce other substances.
<b>Reduction</b>	Chemical reaction which involves in the addition of hydrogen or removal of oxygen or gain of electrons.



## TEXTBOOK EXERCISES



### I. Choose the correct answer.

- Number of valence electrons in carbon is  
a) 2    b) 4    c) 3    d) 5
- Sodium having atomic number 11, is ready to \_\_\_\_\_ electron/ electrons to attain the nearest noble gas electronic configuration.  
a) gain one            b) gain two  
c) lose one            d) lose two
- The element that would form anion by gaining electrons in a chemical reaction is \_\_\_\_\_  
a) potassium    b) calcium  
c) fluorine    d) iron
- Bond formed between a metal and non metal atom is usually \_\_\_\_\_  
a) ionic bond    b) covalent bond  
c) coordinate bond
- \_\_\_\_\_ compounds have high melting and boiling points.  
a) Covalent    b) Coordinate    c) Ionic
- Covalent bond is formed by \_\_\_\_\_  
a) transfer of electrons  
b) sharing of electrons  
c) sharing a pair of electrons
- Oxidising agents are also called as \_\_\_\_\_ because they remove electrons from other substances.  
a) electron donors    b) electron acceptors
- Elements with stable electronic configurations have eight electrons in their valence shell. They are \_\_\_\_  
a) halogens            b) metals  
c) noble gases        d) non metals

### II. Answer briefly.

- How do atoms attain Noble gas electronic configuration?
- NaCl is insoluble in carbon tetrachloride but soluble in water. Give reason.
- Explain Octet rule with an example.
- Write a note on different types of bonds.
- Correct the wrong statements.
  - Ionic compounds dissolve in non polar solvents.
  - Covalent compounds conduct electricity in molten or solution state.
- Complete the table given below.

Element	Atomic number	Electron distribution	Valence electrons	Lewis dot structure
Lithium	3			
Boron	5			
Oxygen	8			

- Draw the electron distribution diagram for the formation of Carbon dioxide ( $\text{CO}_2$ ) molecule.
- Fill in the following table according to the type of bonds formed in the given molecule.  $\text{CaCl}_2$ ,  $\text{H}_2\text{O}$ ,  $\text{CaO}$ ,  $\text{CO}$ ,  $\text{KBr}$ ,  $\text{HCl}$ ,  $\text{CCl}_4$ ,  $\text{HF}$ ,  $\text{CO}_2$ ,  $\text{Al}_2\text{Cl}_6$

Ionic bond	Covalent bond	Coordinate covalent bond



9. The property which is characteristics of an Ionic compound is that
- it often exists as gas at room temperature.
  - it is hard and brittle.
  - it undergoes molecular reactions.
  - it has low melting point.
10. Identify the following reactions as oxidation or reduction
- $\text{Na} \rightarrow \text{Na}^+ + \text{e}^-$
  - $\text{Fe}^{3+} + 2 \text{e}^- \rightarrow \text{Fe}^+$
11. Identify the compounds as Ionic/ Covalent/Coordinate based on the given characteristics.
- Soluble in non polar solvents
  - Undergoes faster/instantaneous reactions
  - Non conductors of electricity
  - Solids at room temperature
12. An atom X with atomic number 20 combines with atom Y with atomic number 8. Draw the dot structure for the formation of the molecule XY.
13. Considering  $\text{MgCl}_2$  as ionic compound and  $\text{CH}_4$  as covalent compound give any two differences between these two compounds.
14. Why are Noble gases inert in nature?

### III. Answer in detail

- List down the differences between Ionic and Covalent compounds.
- Give an example for each of the following statements.
  - A compound in which two Covalent bonds are formed.
  - A compound in which one ionic bond is formed.
  - A compound in which two Covalent and one Coordinate bonds are formed.
  - A compound in which three covalent bonds are formed.
  - A compound in which coordinate bond is formed.
- Identify the incorrect statement and correct them.
  - Like covalent compounds, coordinate compounds also contain charged particles (ions). So they are good conductors of electricity.
  - Ionic bond is a weak bond when compared to Hydrogen bond.
  - Ionic or electrovalent bonds are formed by mutual sharing of electrons between atoms.
  - Loss of electrons is called Oxidation and gain of electron is called Reduction.
  - The electrons which are not involved in bonding are called valence electrons.
- Discuss in brief about the properties of coordinate covalent compounds.
- Find the oxidation number of the elements in the following compounds.
  - C in  $\text{CO}_2$
  - Mn in  $\text{MnSO}_4$
  - N in  $\text{HNO}_3$



### REFERENCE BOOKS

- Modern Inorganic Chemistry  
-R.D.Madan.
- Textbook of Inorganic Chemistry  
-Soni, P.L. and Mohan Katyal.



### INTERNET RESOURCES

- <https://youtu.be/G08rZ6xiIuA>
- <https://youtu.be/LkAykOv1foc>
- <https://youtu.be/DEdRcfyYnSQ>

## Concept Map

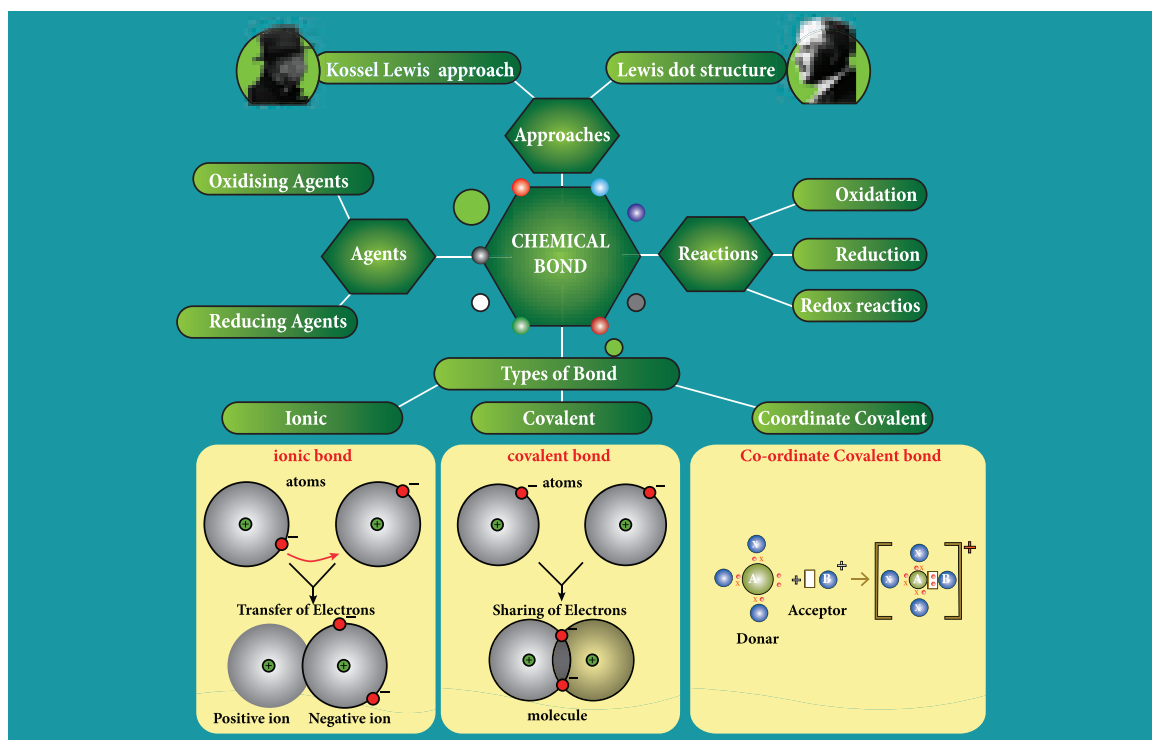

## ICT CORNER

## Chemical Bonding

Explore this activity to know about the various types of Chemical bonding in compounds and to learn chemical formulae.

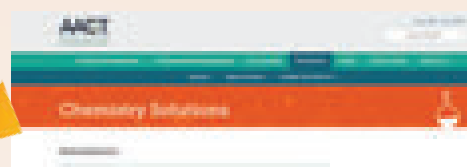

### Steps

- Copy and paste the link given below or type the URL in the browser.
- In the Simulations section, scroll down and select Ionic & Covalent Bonding option.
- Select any two elements which are highlighted in the periodic table.
- Once selected, two options called Ionic Bond or Covalent Bond will appear. In it, click any one of the options to find number of atoms option. Select the numbers and submit the answers to verify.

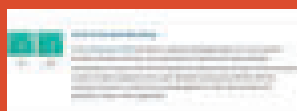

Step1



Step2



Step3



Step4

### Browse in the link:

URL: <https://teachchemistry.org/periodical/simulations> or Scan the QR Code.

\*Pictures are indicative only



B567\_9\_SCI\_EM\_T3



## Learning Objectives

After completing this lesson, students will be able to

- know about formation, properties and uses of acids, bases and salts.
- know the importance of acids, bases and salts in daily life.
- understand how to identify the nature of a solution by using indicators and pH paper.
- know the strength of acid or base solutions.
- define pH scale and explain the significance of pH in everyday life.
- know aquaregia and its properties.

## Introduction

We know that the physical world around us is made of large number of chemicals. Soil, air, water, all the life forms and the materials that they use are all consist of chemicals. Out of such chemicals, acids, bases and salts are mostly used in everyday life. Let it be a fruit juice or a detergent or a medicine, they play a key role in our day-to-day activities. Our body metabolism is carried out by means of hydrochloric acid secreted in our stomach. An acid is a the compound which is capable of forming hydrogen ions ( $H^+$ ) in aqueous solution whereas a base is a compound

that forms hydroxyl ions ( $OH^-$ ) in solution. When an acid and a base react with each other, a neutral product is formed which is called salt. In this lesson let us discuss about them in detail.

### 14.1 Acids

Look at the pictures of some of the materials used in our daily life, given below:

All these edible items taste similar i.e. sour. What causes them to taste sour? A certain type of chemical compounds present in them gives sour taste. These are called acids. The word 'acid' is derived from the Latin name "acidus"

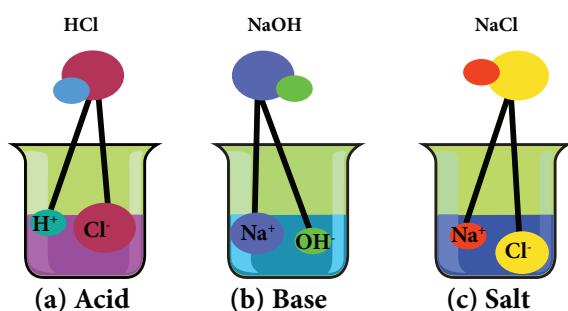

Figure 14.1 Acid, base and salt

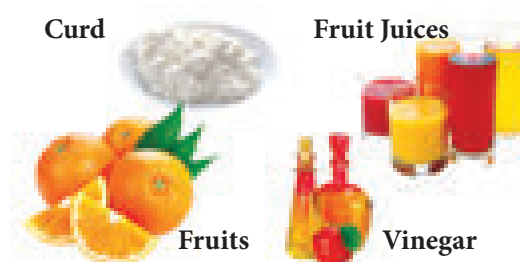

Figure 14.2 Acid, base and salt in food

which means sour taste. Substances with sour taste are called acids.

**Table 14.1** Acid and its source

Source	Acid Present
Apple	Malic acid
Lemon	Citric acid
Grape	Tartaric acid
Tomato	Oxalic acid
Vinegar	Acetic acid
Curd	Lactic acid
Orange	Ascorbic acid
Tea	Tannic acid
Stomach juice	Hydrochloric acid
Stings of Ant, Bee	Formic acid

In 1884, a Swedish chemist Svante Arrhenius proposed a theory on acids and bases. According to Arrhenius theory, an acid is a substance which furnishes  $H^+$  ions or  $H_3O^+$  ions in aqueous solution. They contain one or more replaceable hydrogen atoms. For example, when hydrogen chloride is dissolved in water, it gives  $H^+$  and  $Cl^-$  ions in water.

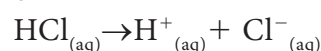

What happens to an acid or a base in water? Do acids produce ions only in aqueous solution? Hydrogen ions in HCl are produced in the presence of water. The separation of  $H^+$  ion from HCl molecules cannot occur in the absence of water.

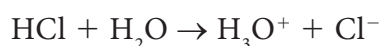

Hydrogen ions cannot exist alone, but they exist in combined state with water molecules. Thus, hydrogen ions must always be  $H^+$  (or) Hydronium ( $H_3O^+$ ).



All acids essentially contain one or more hydrogens. But all the hydrogen containing substances are not acids. For example, methane ( $CH_4$ ) and ammonia ( $NH_3$ ) also contain hydrogen. But they do not produce  $H^+$  ions in aqueous solution.

The following table enlists various acids and the ions formed by them in water.

**Table 14.2** Ions formed by acids

Acid	Molecular Formula	Ions formed		No. of replaceable hydrogen
		$H^+$	$CH_3COO^-$	
Acetic Acid	$CH_3COOH$	$H^+$	$CH_3COO^-$	1
Formic Acid	$HCOOH$	$H^+$	$HCOO^-$	1
Nitric Acid	$HNO_3$	$H^+$	$NO_3^-$	1
Sulphuric Acid	$H_2SO_4$	$2H^+$	$SO_4^{2-}$	2
Phosphoric Acid	$H_3PO_4$	$3H^+$	$PO_4^{3-}$	3

### 14.1.1 Classification of Acids

Acids are classified in different ways as given below:

#### (a) Based on their sources:

**Organic Acids:** Acids present in plants and animals (living things) are organic acids. Example:  $HCOOH$ ,  $CH_3COOH$

**Inorganic Acids:** Acids prepared from rocks and minerals are inorganic acids or mineral acids. Example:  $HCl$ ,  $HNO_3$ ,  $H_2SO_4$

#### (b) Based on their Basicity

**Monobasic Acid:** Acid that contain only one replaceable hydrogen atom per molecule is called monobasic acid. It gives one hydrogen ion per molecule of the acid in solution. Example:  $HCl$ ,  $HNO_3$



For acids, we use the term basicity that refers to the number of replaceable hydrogen atoms present in one molecule of an acid. For example, acetic acid ( $CH_3COOH$ ) has four hydrogen atoms but only one can be replaced. Hence it is monobasic.

**Dibasic Acid:** An acid which gives two hydrogen ions per molecule of the acid in solution. Example:  $H_2SO_4$ ,  $H_2CO_3$

**Tribasic Acid:** An acid which gives three hydrogen ions per molecule of the acid in solution. Example:  $\text{H}_3\text{PO}_4$

### (c) Based on Ionisation

Acids get ionised in water (produce  $\text{H}^+$  ions) completely or partially. Based on the extent of ionisation acids are classified as below.

**Strong Acids:** These are acids that ionise completely in water. Example:  $\text{HCl}$

**Weak Acids:** These are acids that ionise partially in water. Example:  $\text{CH}_3\text{COOH}$ .



Ionisation is the condition of being dissociated into ions by heat or radiation or chemical reactions or electrical discharge.

### (d) Based on Concentration

**Concentrated Acid:** It has relatively large amount of acid dissolved in a solvent.

**Dilute Acid:** It has relatively smaller amount of acid dissolved in solvent.

## 14.1.2 Properties of Acids

- They have sour taste.
- Their aqueous solutions conduct electricity since they contain ions.
- Acids turn blue litmus red.
- Acids react with active metals to give hydrogen gas.

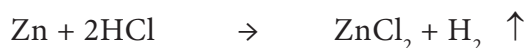
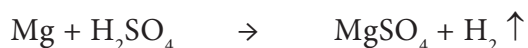

Few metals do not react with acid and liberate hydrogen gas. For example:  $\text{Ag}$ ,  $\text{Cu}$ .

- Acids react with metal carbonate and metal hydrogen carbonate to give carbon dioxide.



- Acids react with metallic oxides to give salt and water.

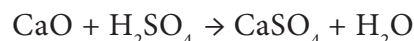

- Acids react with bases to give salt and water.

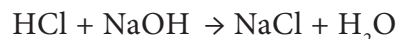

The reaction is known as neutralisation reaction.

### Activity 1

Take about 10 ml of dilute hydrochloric acid in a test tube and add a few pieces of zinc granules into it. What do you observe? Why are bubbles formed in the solution? Take a burning candle near a bubble containing hydrogen gas, the flame goes off with a 'Popping' sound. This confirms that metal displaces hydrogen gas from the dilute acid.

**Caution:** Care must be taken while mixing any concentrated inorganic acid with water. The acid must be added slowly and carefully with constant stirring to water since it generates large amount of heat. If water is added to acid, the mixture splashes out of the container and it may cause burns.

## 14.1.3 Uses of Acids

- Sulphuric acid is called King of Chemicals because it is used in the preparation of many other compounds. It is used in car batteries also.
- Hydrochloric acid is used as a cleansing agent in toilets.
- Citric acid is used in the preparation of effervescent salts and as a food preservative.
- Nitric acid is used in the manufacture of fertilizers, dyes, paints and drugs.
- Oxalic acid is used to clean iron and manganese deposits from quartz crystals. It is also used as bleach for wood and removing black stains.
- Carbonic acid is used in aerated drinks.
- Tartaric acid is a constituent of baking powder.





### Role of water in acid solution

Acids show their properties only when dissolved in water.

In water, they ionise to form  $H^+$  ions which determine the properties of acids. They do not ionise in organic solvents. For example, when HCl is dissolved in water it produces  $H^+$  ions and  $Cl^-$  ions whereas in organic solvents like ethanol they do not ionise and remain as molecule.

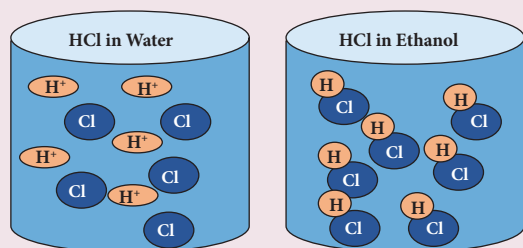

#### 14.1.4 Aquaregia

We know that metals like gold and silver are not reactive with either HCl or  $HNO_3$ . But the mixture of these two acids can dissolve gold. This mixture is called Aquaregia. It is a mixture of hydrochloric acid and nitric acid prepared optimally in a molar ratio of 3:1. It is a yellow-orange fuming liquid. It is a highly corrosive liquid, able to attack gold and other substances.

Chemical formula :  $3 HCl + HNO_3$

Solubility in Water : Miscible in water

Melting point :  $-42^\circ C$  ( $-44^\circ F$ , 231K)

Boiling point :  $108^\circ C$  ( $226^\circ F$ , 381K)

Table 14.3 Ions formed by bases in water.

Base	Molecular Formula	Ions formed		No. of replaceable hydroxyl ion
Calcium oxide	CaO	$Ca^{2+}$	$O^{2-}$	1
Sodium oxide	$Na_2O$	$Na^+$	$O^{2-}$	1
Potassium hydroxide	KOH	$K^+$	$OH^-$	1
Calcium hydroxide	$Ca(OH)_2$	$Ca^{2+}$	$OH^-$	2
Aluminium hydroxide	$Al(OH)_3$	$Al^{3+}$	$OH^-$	3

The term aquaregia is a Latin phrase meaning 'King's Water'. The name reflects the ability of aquaregia to dissolve the noble metals such as gold, platinum and palladium.

### Uses of Aquaregia

1. It is used chiefly to dissolve metals such as gold and platinum.
2. It is used for cleaning and refining gold.

## 14.2 Bases

According to Arrhenius theory, bases are substances that ionise in water to form hydroxyl ions ( $OH^-$ ). There are some metal oxides which give salt and water on reaction with acids. These are also called bases. Bases that are soluble in water are called alkalis. A base reacts with an acid to give salt and water only.

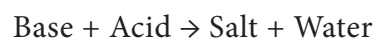

For example, zinc oxide ( $ZnO$ ) reacts with HCl to give the salt zinc chloride and water.

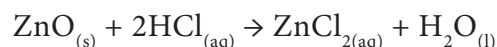

Similarly, sodium hydroxide ionises in water to give hydroxyl ions and thus get dissolved in water. So it is an alkali.

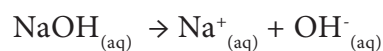

Bases contain one or more replaceable oxide or hydroxyl ions in solution. Table 14.3 enlists various bases and ions formed by them in water.



All alkalis are bases but not all bases are alkalis. For example: NaOH and KOH are alkalis whereas  $Al(OH)_3$  and  $Zn(OH)_2$  are bases.

## 14.2.1 Classification of Bases

### (a) Based on their Acidity

**Monoacidic Base:** It is a base that ionises in water to give one hydroxide ion per molecule.  
Example: NaOH, KOH

**Diacidic Base:** It is a base that ionises in water to give two hydroxide ions per molecule.  
Example:  $\text{Ca}(\text{OH})_2$ ,  $\text{Mg}(\text{OH})_2$

**Triacidic Base:** It is a base that ionises in water to give three hydroxide ions per molecule.  
Example:  $\text{Al}(\text{OH})_3$ ,  $\text{Fe}(\text{OH})_3$

### (b) Based on concentration

**Concentrated Alkali:** It is an alkali having a relatively high percentage of alkali in its aqueous solution.

**Dilute Alkali:** It is an alkali having a relatively low percentage of alkali in its aqueous solution.

### (c) Based on Ionisation

**Strong Bases:** These are bases which ionise completely in aqueous solution.

Example: NaOH, KOH

**Weak Bases:** These are bases that ionise partially in aqueous solution.

Example:  $\text{NH}_4\text{OH}$ ,  $\text{Ca}(\text{OH})_2$



The term acidity is used for base, which means the number of replaceable hydroxyl groups present in one molecule of a base.

## 14.2.2 Properties of Bases

- They have bitter taste.
- Their aqueous solutions have soapy touch.
- They turn red litmus blue.
- Their aqueous solutions conduct electricity.
- Bases react with metals to form salt with the liberation of hydrogen gas.

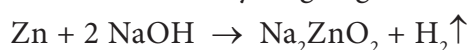

- Bases react with non-metallic oxides to produce salt and water. Since this is similar to the reaction between a base

and an acid, we can conclude that non-metallic oxides are acidic in nature.

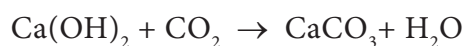

- Bases react with acids to form salt and water.

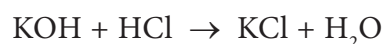

The above reaction between a base and an acid is known as Neutralisation reaction.

- On heating with ammonium salts, bases give ammonia gas.

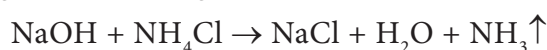

Few metals do not react with sodium hydroxide.  
Example: Cu, Ag, Cr

### Activity 2

Take solutions of hydrochloric acid or sulphuric acid. Fix two nails on a cork and place the cork in a 100 ml beaker. Connect the nails to the two terminals

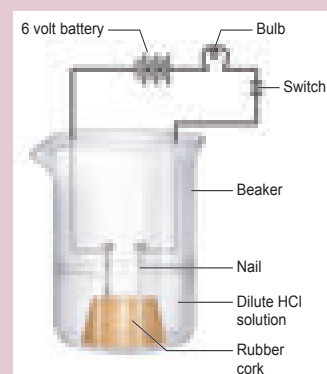

of a 6V battery through a bulb and a switch as shown in Figure. Now pour some dilute HCl in the beaker and switch on the current. Repeat the activity with dilute sulphuric acid, glucose and alcohol solutions. What do you observe now? Does the bulb glow in all cases?

In the above activity you can observe that the bulb will start glowing only in the case of acids. But, you will observe that glucose and alcohol solution do not conduct electricity. Glowing of the bulb indicates that there is a flow of electric current through the solution. The electric current is carried through the solution by ions. Repeat the same activity using alkalis such as sodium hydroxide and calcium hydroxide.

**Try Yourself:** Construct a Lemon cell as shown in picture.

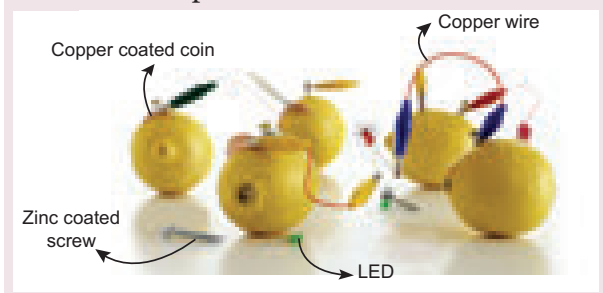

### 14.2.3 Uses of Bases

- Sodium hydroxide is used in the manufacture of soap.
- Calcium hydroxide is used in white washing of building.
- Magnesium hydroxide is used as a medicine for stomach disorder.
- Ammonium hydroxide is used to remove grease stains from cloths.

## 14.3 Tests for Acids and Bases

### a) Test with a litmus paper:

An acid turns blue litmus paper into red. A base turns red litmus paper into blue.

### b) Test with an indicator Phenolphthalein:

In acid medium, phenolphthalein is colourless. In basic medium, phenolphthalein is pink in colour.

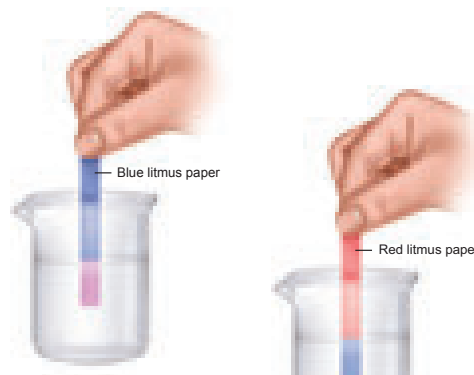

**Figure 14.3** Test for acid and base using litmus paper

### c) Test with an indicator Methyl orange:

In acid medium, methyl orange is pink in colour. In basic medium, methyl orange is yellow in colour.



**Figure 14.4** Test for acid and base using indicator

**Table 14.4** Acid base indicator

Indicator	Colour in acid	Colour in base
Litmus	Blue to Red	Red to Blue
Phenolphthalein	Colourless	Pink
Methyl orange	Pink	Yellow

### Activity 3

Collect the following samples from the science laboratory – Hydrochloric acid, Sulphuric acid and Nitric acid, Sodium hydroxide, Potassium hydroxide. Take 2 ml of each solution in a test tube and test with a litmus paper and indicators phenolphthalein and Methyl orange. Tabulate your observations.

Sample Solutions	Litmus Paper		Indicators	
	Blue	Red	Phenolphthalein	Methyl Orange
Hydrochloric acid				
Sulphuric acid				
Nitric acid				
Sodium hydroxide				
Potassium hydroxide				

## 14.4 Strength of Acidic or Basic solutions

### pH Scale

A scale for measuring hydrogen ion concentration in a solution is called pH scale. The 'p' in pH stands for 'potenz' in German meaning power. pH scale is a set of numbers from 0 to 14 which is used to indicate whether a solution is acidic, basic or neutral.

- ✓ Acids have pH less than 7
- ✓ Bases have pH greater than 7
- ✓ A neutral solution has pH equal to 7

## 14.5 Salts

When you say salt, you may think of the common salt. Sea water contains many salts dissolved in it. Sodium chloride is separated from these salts.



There are many other salts used in other fields. Salts are the products of the reaction between acids and bases. Salts produce positive ions and negative ions when dissolved in water.



### 14.5.1 Types of Salts

**Normal Salts:** A normal salt is obtained by complete neutralization of an acid by a base.

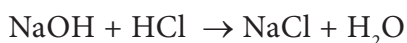

**Acid Salts:** It is derived from the partial replacement of hydrogen ions of an acid by a metal. When a calculated amount of a base is added to a polybasic acid, acid salt is obtained.

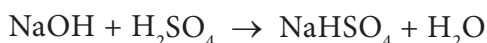

**Basic Salts:** Basic salts are formed by the partial replacement of hydroxide ions of a diacidic or triacidic base with an acid radical.

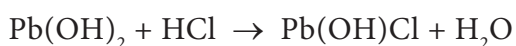

**Double Salts:** Double salts are formed by the combination of the saturated solution of two simple salts in equimolar ratio followed by crystallization. For example, potash alum is a mixture of potassium sulphate and aluminium sulphate.  $\text{KAl(SO}_4)_2 \cdot 12\text{H}_2\text{O}$

### 14.5.2 Properties of Salts

- ✓ Salts are mostly solids which melt as well as boil at high temperature.
- ✓ Most of the salts are soluble in water. For example, chloride salts of potassium and sodium are soluble in water. But, silver chloride is insoluble in water
- ✓ They are odourless, mostly white, cubic crystals or crystalline powder with salty taste.
- ✓ Salt is hygroscopic in nature.

### 14.5.3 Water of Crystallisation

Many salts are found as crystals with water molecules. These water molecules are known as water of crystallisation. Salts that contain water of crystallisation are called hydrated salts. The number of molecules of water hydrated to a salt is indicated after a dot in its chemical formula. For example, copper sulphate crystal have five molecules of water for each molecule of copper sulphate. It is written as  $\text{CuSO}_4 \cdot 5\text{H}_2\text{O}$  and named as copper sulphate pentahydrate. This water of crystallisation makes the copper sulphate blue. When it is heated, it loses its water molecules and becomes white.

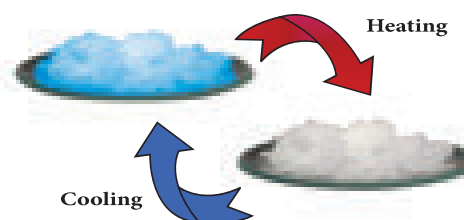

Figure 6.7 Hydrated Salt

Salts that do not contain water of crystallisation are called anhydrous salt. They are generally found as powders. Fill in the blanks in the following table based on the concept of water of crystallisation.

## Activity 4

Fill in the blanks in the following table based on the concept of water of crystallisation.

Salt	Formula of anhydrous salt	Formula of hydrated salt	Name of hydrated salt
Zinc sulphate	$\text{ZnSO}_4$	$\text{ZnSO}_4 \cdot 7\text{H}_2\text{O}$	
Magnesium chloride	$\text{MgCl}_2$		Magnesium chloride hexahydrate
Iron (II) sulphate		$\text{FeSO}_4 \cdot 7\text{H}_2\text{O}$	Iron (II) sulphate heptahydrate
Calcium chloride	$\text{CaCl}_2$	$\text{CaCl}_2 \cdot 2\text{H}_2\text{O}$	
Sodium thiosulphate	$\text{Na}_2\text{S}_2\text{O}_3$		Sodium thiosulphate pentahydrate

### 14.5.4 Identification of Salts

#### (i) Physical examination of the salt.

The physical examination of the unknown salt involves the study of colour, smell and density. This test is not much reliable.

#### (ii) Dry heating Test.

This test is performed by heating a small amount of salt in a dry test tube. After all the water get evaporated, the dissolved salts are sedimented in the container.

#### (iii) Flame Test.

Certain salts on reacting with concentrated hydrochloric acid (HCl) form their chlorides. The paste of the mixture with con. HCl is introduced into the flame with the help of platinum wire.

Colour of the flame	Inference
Brick red	$\text{Ca}^{2+}$
Golden Yellow	$\text{Na}^+$
Pink Violet	$\text{K}^+$
Green Fleshes	$\text{Zn}^{2+}$

(iv) When HCl is added with a carbonate salt, it gives off  $\text{CO}_2$  gas with brisk effervescence.

### 14.5.5 Uses of Salts

#### Common Salt (Sodium Chloride - NaCl)

It is used in our daily food and used as a preservative.

#### Washing Soda (Sodium Carbonate- $\text{Na}_2\text{CO}_3$ )

- It is used in softening hard water.
- It is used in glass, soap and paper industries.

#### Baking Soda (Sodium bicarbonate - $\text{NaHCO}_3$ )

- It is used in making of baking powder which is a mixture of baking soda and tartaric acid.
- It is used in soda-acid fire extinguishers.
- Baking powder is used to make cakes and bread, soft and spongy.
- It neutralizes excess acid in the stomach and provides relief.

#### Bleaching powder

##### (Calcium Oxychloride - $\text{CaOCl}_2$ )

- It is used as disinfectant.
- It is used in textile industry for bleaching cotton and linen.

#### Plaster of Paris (Calcium Sulphate Hemihydrate - $\text{CaSO}_4 \cdot \frac{1}{2} \text{H}_2\text{O}$ )

- It is used for plastering bones.
- It is used for making casts for statues.

## Activity 5

Boil about 100 ml of ground water in a vessel to dryness. After all the water get evaporated observe the inner wall of the vessel. Can you observe any deposits? This is the deposit of dissolved salts present in water.

### Points to Remember

- ❖ Acid is a substance which furnishes  $H^+$  ions or  $H_3O^+$  ions when dissolved in water.
- ❖ Base is a substance which releases  $OH^-$  ions when dissolved in water.
- ❖ Salt is the product of reaction between acids and bases.
- ❖ Acids and bases neutralize each other to form corresponding salts and water.
- ❖ Salts have various uses in everyday life.
- ❖ Acidic and basic solutions in water conduct electricity because they produce hydrogen and hydroxide ions respectively.
- ❖ When an acid reacts with a metal, hydrogen gas is evolved and a corresponding salt is formed.
- ❖ Phenolphthalein and Methyl orange are used as indicators to find out whether the given solution is acid or base.
- ❖ Litmus paper is also used to find out whether the given solution is acid or base.
- ❖ pH paper is used to find out the given solution whether acidic or basic in nature.
- ❖ Aquaregia is a mixture of hydrochloric acid and nitric acid optimally in a molar ratio of 3:1.
- ❖ pH Scale is used to find out the power of hydrogen ion concentration in a solution.

### A-Z GLOSSARY

<b>Acids</b>	Substance which furnishes $H^+$ ions $H_3O^+$ ions when dissolved in water.
<b>Bases</b>	Substance which furnishes $OH^-$ ions when dissolved in water.
<b>Salts</b>	Product of reaction between acids and bases.
<b>Indicators</b>	Chemical substances used to find out whether the given solution is acid or base.
<b>pH Scale</b>	Scale used to find out Hydrogen ion concentration in a solution.
<b>pH Paper</b>	Paper used to find out whether the given solution is acidic or basic or neutral in nature.
<b>Aquaregia</b>	Mixture of hydrochloric acid and nitric acid prepared optimally in a molar ratio of 3 : 1.
<b>Hygroscopic substance</b>	Substance which absorbs water from the surroundings.



### TEXTBOOK EXERCISES

#### I. Choose the correct answer.

1.  $Zn + 2 HCl \rightarrow ZnCl_2 + \dots \uparrow (H_2, O_2, CO_2)$
2. Apple contains malic acid. Orange contains \_\_\_\_\_ (citric acid, ascorbic acid).
3. Acids in plants and animals are organic acids. Whereas Acids in rocks and minerals are \_\_\_\_\_ (Inorganic acids, Weak acids).
4. Acids turn blue litmus paper to \_\_\_\_\_ (green, red, orange).
5. Since metal carbonate and metal bicarbonate are basic, they react with acids to give salt and water with the liberation of \_\_\_\_\_ ( $NO_2, SO_2, CO_2$ ).

6. The hydrated salt of copper sulphate has \_\_\_\_\_ colour (red, white, blue).

#### II. Answer briefly.

1. Classify the various types of Acids based on their sources.
2. Write any four uses of acids.
3. Give the significance of pH of soil in agriculture.
4. What are the various uses of Aquaregia.
5. What are the uses of Plaster of Paris?
6. Two acids 'A' and 'B' are given. Acid A gives one hydrogen ion per molecule of the acid in solution. Acid B gives two hydrogen ions per molecule of the acid in solution.

(i) Find out acid A and acid B. (ii) Which acid is called the King of Chemicals?

7. Define aquaregia.

8. Correct the mistakes:

a) Washing soda is used for making cakes and bread soft, spongy.

b) Calcium sulphate hemihydrate is used in textile industry for bleaching cloths.

9. What is neutralization reaction? Give an example.

3. Write any four uses of bases.

4. Write any five uses of salts.

5. Sulphuric acid is called King of Chemicals. Why is it called so?



## REFERENCE BOOKS

1. Chemistry-Lakhmir Singh & Manjit Kaur
2. Practical Chemistry-Dr. N.K. Verma



## INTERNET RESOURCES

1. <https://www.thoughtco.com>
2. Aquaregia Wikipedia
3. <https://scienceing.com>>Chemistry

### III. Answer in detail.

1. Differentiate hydrate and anhydrous salts with examples.

2. Give the tests to identify Acids and Bases.

### Concept Map

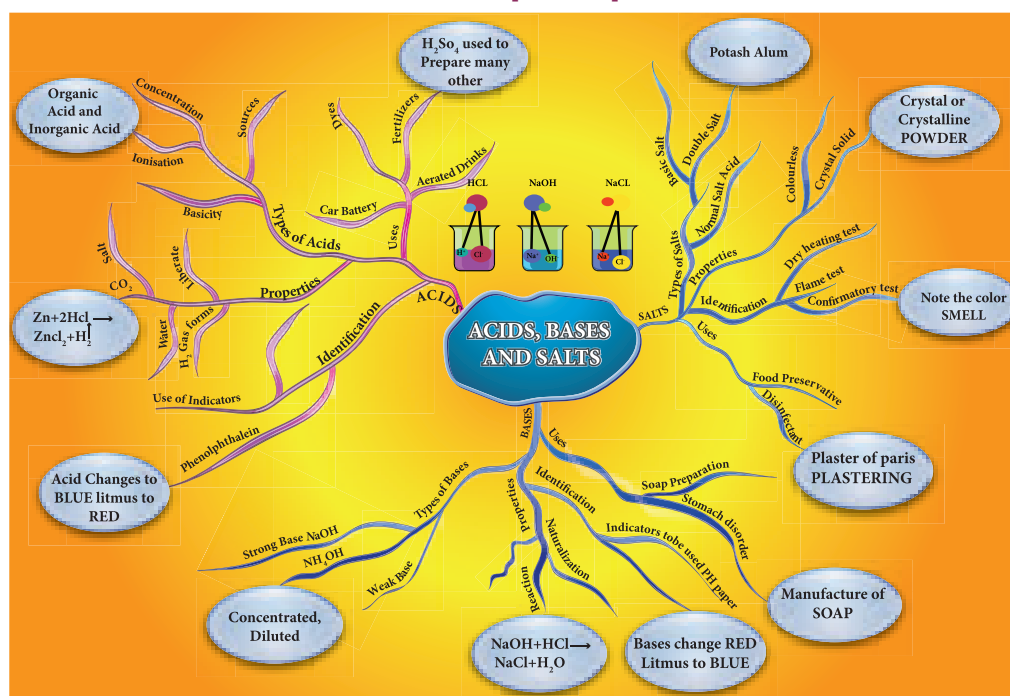

### ICT CORNER

#### Steps

- Type the URL link given below in the browser or scan the QR code. You can view “Acids and bases”.
- Click the ‘pH meter’ to explore the properties based on the pH value.
- Click the ‘pH paper’ to explore the properties based on the colour of pH paper .
- Also you can see the nature of the acids, bases using the conductivity.

#### Browse in the link:

URL: <https://phet.colorado.edu/en/simulation/acid-base-solutions>



B567\_9\_SCI\_EM\_T3

# CARBON AND ITS COMPOUNDS

## Learning Objectives



After completing this lesson, students will be able to

- explain the special features of carbon.
- know about the isomerism and allotropic forms of carbon compounds.
- differentiate between the properties of graphite and diamond.
- recognise the various inorganic carbon compounds with their uses.
- know the common properties of carbon compounds.
- identify the codes of various plastics.
- understand the effects of plastics on human life and environment.
- know the legal measures to prevent plastic pollution.

## Introduction

Carbon is one of the most important **non-metallic** element. Antoine Lavoisier named Carbon from the Latin word '**Carbo**' meaning coal. This is because carbon is the main constituent of coal. Coal is a fossil fuel developed from prolonged decomposition of buried plants and animals. So, it is clear that all the life forms contain carbon. The earth's crust contains only 0.032% of carbon (i.e. 320 parts per million by weight) in the form of minerals like carbonates, coal and petroleum and the atmosphere has only 0.03% of carbon dioxide (i.e. 300 parts per million by weight). Even though available in small amount in nature, carbon compounds have an immense importance in everyday life.

Carbon is present in our muscles, bones, organs, blood and other components of living matter. A large number of things which we

use in our daily life are made up of carbon compounds. So, without carbon there is no possibility for the existence of plants and animals including human. Thus, **Carbon Chemistry** is also called as **Living Chemistry**. In this lesson we will study about the special features of carbon, its properties and also about plastic which are the catenated long chain compounds.

## 15.1 Discovery of Carbon-Milestones

Carbon has been known since ancient times in the form of soot, charcoal, graphite and diamonds. Ancient cultures did not realize, of course, that these substances were different forms of the same element.

In 1772, French scientist **Antoine Lavoisier** pooled resources with other chemists to buy a diamond, which they placed in a closed glass jar.



They focused the Sun's rays on the diamond with a remarkable giant magnifying glass and saw the diamond burn and disappear. Lavoisier noted that the overall weight of the jar was unchanged and that when it burned, the diamond had combined with oxygen to form carbon dioxide. He concluded that diamond and charcoal were made of the same element – carbon.

In 1779, Swedish scientist **Carl Scheele** showed that graphite also burned to form carbon dioxide. In 1796, English chemist **Smithson Tennant** established that diamond is pure carbon and not a compound of carbon and it burned to form only carbon dioxide. Tennant also proved that when equal weights of charcoal and diamonds were burned, they produced the same amount of carbon dioxide.

In 1855, English chemist **Benjamin Brodie** produced pure graphite from carbon, proving graphite is a form of carbon. Although it had been previously attempted without success, in 1955 American scientist **Francis Bundy** and his co-workers at 'General Electric' company finally demonstrated that graphite could be transformed into diamond at high temperature and pressure.

In 1985, **Robert Curl, Harry Kroto and Richard Smalley** discovered fullerenes, a new form of carbon in which the atoms are arranged in soccer-ball shapes. **Graphene**, consists of a single layer of carbon atoms arranged in hexagons. Graphene's discovery was announced in 2004 by **Kostya Novoselov and Andre Geim**, who used adhesive tape to detach a single layer of atoms from graphite to produce the new allotrope. If these layers were stacked upon one other, graphite would be the result. Graphene has a thickness of just one atom.

## 15.2 Compounds of Carbon – Classification

Carbon is found both in free state as well as combined state in nature. In the pre-historic period, ancients used to manufacture charcoal by burning organic materials. They used to

obtain carbon compounds both from living things as well as non-living matter. Thus, in the early 19<sup>th</sup> century, Berzelius classified carbon compounds based on their source as follows:

**Organic Carbon Compounds:** These are the compounds of carbon obtained from living organisms such as plants and animals. e.g. Ethanol, cellulose, Starch.

**Inorganic Carbon Compounds:** These are the compounds containing carbon but obtained from non-living matter. e.g. Calcium Carbonate, Carbon Monoxide, Carbon dioxide.

### 15.2.1 Organic Compounds of Carbon

There are millions of organic carbon compounds available in nature and also synthesized manually. Organic carbon compounds contain carbon connected with other elements like hydrogen, oxygen, nitrogen, sulphur etc. Thus, depending on the nature of other elements and the way in which they are connected with carbon, there are various classes of organic carbon compounds such as hydrocarbons, alcohols, aldehydes and ketones, carboxylic acids, amino acids, etc. You will study about organic carbon compounds in your higher classes.

### 15.2.2 Inorganic Compounds of Carbon

As compared to organic compounds, the number of inorganic carbon compounds are limited. Among them oxides, carbides, sulphides, cyanides, carbonates and bicarbonates are the major classes of inorganic carbon compounds. Formation, properties and uses of some of these compounds are given in Table 15.1.

## 15.3 Special Features of Carbon

The number of carbon compounds known at present is more than 5 million. Many newer carbon compounds are being isolated or prepared every day. Even though the abundance

**Table 15.1 Inorganic carbon compounds**

Compounds	Formation	Properties	Uses
<b>Carbon monoxide</b> (CO)	Not a natural component of air. Mainly added to atmosphere due to incomplete combustion of fuels.	Colourless, odourless, highly toxic, sparingly soluble in water.	Main component of water gas (CO+H <sub>2</sub> ). Reducing agent.
<b>Carbon dioxide</b> (CO <sub>2</sub> )	Occurs in nature as free and combined forms. Combined form is found in minerals like limestone, magnesite. Formed by complete combustion of carbon or coke.	Colourless, odourless, tasteless Stable, highly soluble in water, takes part in photosynthesis.	Fire extinguisher, preservative for fruits, making bread, to manufacture urea, carbonated water, nitrogenous fertilizers, dry ice in refrigerator
<b>Calcium Carbide</b> (CaC <sub>2</sub> )	Prepared by heating calcium oxide and coke.	Greyish black solid.	To manufacture graphite and hydrogen. To prepare acetylene gas for welding.
<b>Carbon disulphide</b> (CS <sub>2</sub> )	Directly prepared from Carbon and Sulphur	Colourless, inflammable, highly poisonous gas.	Solvent for sulphur. To manufacture rayon, fungicide, insecticide
<b>Calcium Carbonate</b> (CaCO <sub>3</sub> )	Prepared by passing Carbondioxide into the solution of slaked lime	Crystalline solid, insoluble in water.	Antacid
<b>Sodium bicarbonate</b> (NaHCO <sub>3</sub> )	Formed by treating sodium hidroxide with carbonic acid (H <sub>2</sub> CO <sub>3</sub> )	White crystalline substance, sparingly soluble in water	Preparation of sodium carbonate, baking powder, antacid

of carbon is less, the number of carbon compounds alone is more than the number of compounds of all the elements taken together. Why is it that this property is seen in carbon and in no other elements? Because, carbon has the following unique features.

### 15.3.1 Catenation

Catenation is **binding of an element to itself or with other elements through covalent bonds** to form open chain or closed chain compounds. Carbon is the most common element which undergoes catenation and forms long chain compounds. Carbon atom links repeatedly to itself through covalent bond

to form linear chain, branched chain or ring structure.

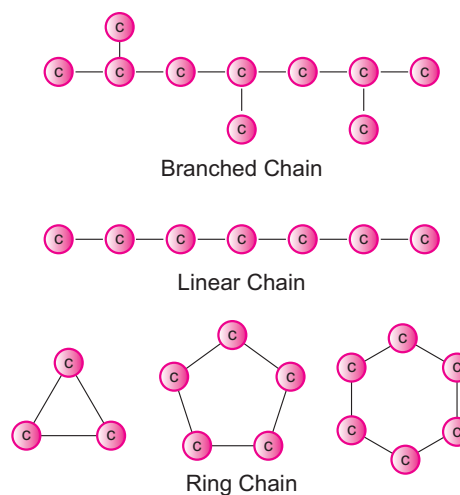

**Figure 15.1** Catenation in carbon

This property of carbon itself is the reason for the presence of large number of organic carbon compounds. So organic chemistry essentially deals with catenated carbon compounds.

### Activity 1

With the help of your teacher, try to classify the following as organic and inorganic compounds.

HCN, CO<sub>2</sub>, Propane, PVC, CO, Kerosene, LPG, Coconut oil, Wood, Perfume, Alcohol, Na<sub>2</sub>CO<sub>3</sub>, CaCO<sub>3</sub>, MgO, Cotton, Petrol.

For example, starch and cellulose contain chains of hundreds of carbon atoms. Even plastics we use in our daily life are macro molecules of catenated carbon compounds.

### 15.3.2 Tetravalency

Another versatile nature of carbon is its tetravalency. The shell electronic configuration of carbon is 2,4 (Atomic no: 6). It has four electrons in its outermost orbit. According to Octet Rule, carbon requires four electrons to attain nearest noble gas (Neon) electronic configuration. So carbon has the tendency to share its four electrons with other atoms to complete its octet. This is called its **tetravalency**. Thus, carbon can form four covalent bond with other elements.

For example, in methane, carbon atom shares its four valence electrons with four hydrogen atoms to form four covalent bonds and hence tetravalent.

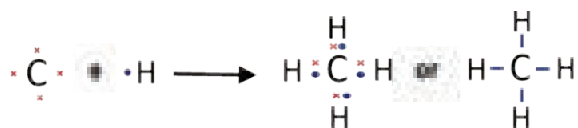

### 15.3.3 Multiple Bonds

As seen above, the tetravalent carbon can form four covalent bonds. With this tetravalency, carbon is able to combine with other elements or with itself through **single bond, double bond and triple bond**. As we

know, the nature of bonding in a compound is the primary factor which determines the physical and chemical characteristics of a compound. So, the ability of carbon to form multiple bonds is the main reason for the existence of various classes of carbon compounds. Table 15.2 shows one of such classes of compounds called '**hydrocarbons**' and the type of bonding in them.

Table 15.2 Hydrocarbon

Type of bond	Example	Class of the compound
Single Bond	$\begin{array}{c} \text{H} \\   \\ \text{H}-\text{C}-\text{H} \\   \\ \text{H} \end{array}$ Methane	Alkane
Double Bond	$\begin{array}{c} \text{H} \quad \text{H} \\   \quad   \\ \text{H}-\text{C}=\text{C}-\text{H} \end{array}$ Ethene	Alkene
Triple Bond	$\text{H}-\text{C}\equiv\text{C}-\text{H}$ Ethyne	Alkyne

When one or more hydrogen in hydrocarbons is replaced by other elements like O, N, S, halogens, etc., a variety of compounds having different functional groups are produced. You will study about them in your higher class.

### 15.3.4 Isomerism

Isomerism is another special feature of carbon compounds especially found in catenated organic compounds. Let us consider the molecular formula of an organic compound C<sub>2</sub>H<sub>6</sub>O. Can you name the compound? You can't. Because the molecular formula of an organic compound represents only the number of different atoms present in that compound. It does not tell about the way in which the atoms are arranged and hence its structure. Without knowing the structure, we can't name it.

A given molecular formula may lead to more than one arrangement of atoms. Such compounds are having different physical

and chemical properties. This phenomenon in which the **same molecular formula may exhibit different structural arrangement** is called isomerism. Compounds that have the same molecular formula but different structural formula are called isomers (Greek, isos = equal, meros = parts).

#### Illustration:

The given formula  $C_2H_6O$  is having two kinds of arrangement of atoms as shown below.

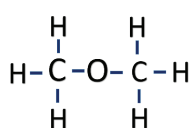
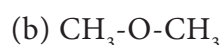
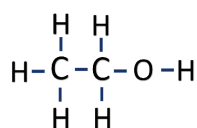
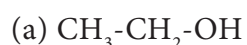

Both the compounds have same molecular formula but different kind of arrangements. In compound 'a', the oxygen atom is attached to a hydrogen and a carbon. It is an alcohol. Whereas in compound 'b', the oxygen atom is attached to two carbon atoms and it is an **ether**. These compounds have different physical and chemical properties. You will study about isomerism in detail in higher classes.

### 15.3.5 Allotropy

**Allotropy** is a property by which an element can exist in more than one form that are physically different and chemically similar. The different forms of that element are called its allotropes. The main reason for the existence of allotropes of an element is its method of formation or preparation. Carbon exists in different allotropic forms and based on their physical nature they are classified as below.

**Table 15.3** Difference between Diamond and Graphite

Diamond	Graphite
Each carbon has four covalent bonds.	Each carbon has three covalent bonds.
Hard, heavy and transparent.	Soft, slippery to touch and opaque.
It has tetrahedral units linked in three dimension.	It has planar layers of hexagon units.
It is a non-conductor of heat and electricity.	It is a conductor of heat and electricity.

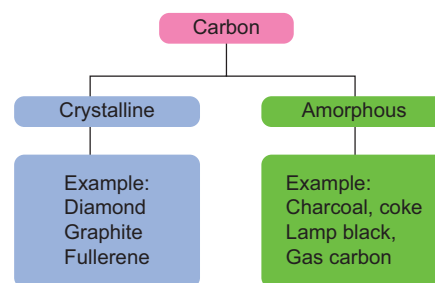

#### (a) Crystalline forms of Carbon

##### Diamond:

- ❖ In diamond, each carbon atom shares its four valence electrons with four other carbon atoms forming four covalent bonds.
- ❖ Here the atoms are arranged in repeated **tetrahedral** fashion which leads to a **three dimensional structure accounting** for its hardness and rigidity.

##### Graphite:

- ❖ In graphite, each carbon atom is bonded to three other carbon atoms through covalent bonds in the same plane.
- ❖ This arrangement forms hexagonal layers which are held together one over other by weak Vander Waals forces.
- ❖ Since the layers are held by weak forces, graphite is softer than diamond.

##### Fullerene:

- ❖ The third crystalline allotrope of carbon is fullerene. The best known fullerene is **Buckminster fullerene**, which consists of 60 carbon atoms joined together in a series of 5- and 6- membered to form spherical molecule resembling a soccer ball. So its formula is  $C_{60}$ .
- ❖ This allotrope was named as **Buckminster fullerene** after the American architect

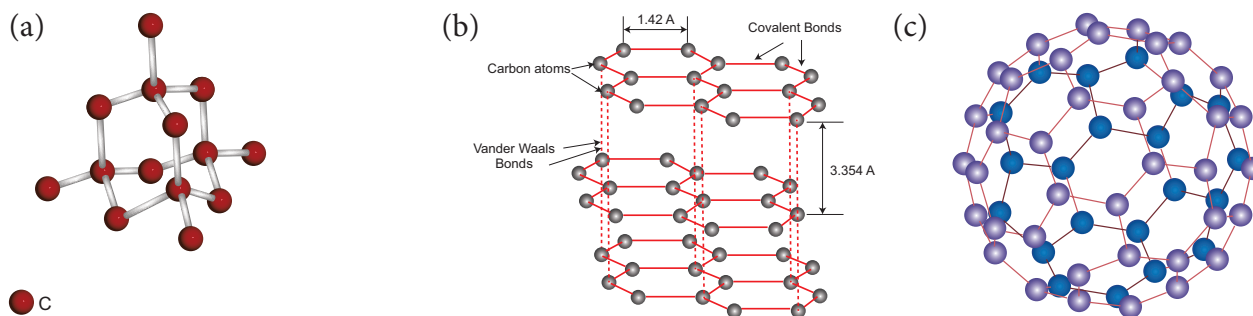

**Figure 15.2** Crystalline forms of Carbon

**Buckminster fuller.** Because its structure reminded the framework of **dome shaped halls** designed by Fuller for large international exhibitions, it is called by the pet name **Bucky Ball**. A large family of fullerenes exists, starting at  $C_{20}$  and reaching up to  $C_{540}$ .

### Activity 2

Take a football since it resembles to Buckminster fullerene. Count how many hexagonal and pentagonal panels are in it. Every corner is considered as one carbon. Compare your observation with fullerene and discuss with your friends.

### More to Know

**Graphene** is most recently produced allotrope of carbon which consists of honeycomb shaped hexagonal ring repeatedly arranged in a plane. Graphene is the thinnest compound known to man at one atom thick. It is the lightest material known (with 1 square metre weighing around 0.77 milligrams) and the strongest compound discovered (100-300 times stronger than steel). It is a best conductor of heat at room temperature. Layers of graphene are stacked on top of each other to form graphite, with an inter planar spacing of 0.335 nanometres. The separate layers of graphene in graphite are held together by Vander Waals forces.



### (b) Amorphous forms of carbon

In amorphous form of carbon, carbon atoms are arranged in random manner. These form of carbon are obtained when wood is heated in the absence of air. E.g., charcoal

## 15.4 Physical properties of Carbon and its compounds

- ❖ Carbon is a non-metal found in various allotropic forms from soft powder to hard solid.
- ❖ All the allotropic forms of carbon are solids whereas its compounds exist in solid, liquid and gaseous state.
- ❖ Amorphous forms of carbon and graphite are almost black in colour and opaque. Diamond is transparent and shiny.
- ❖ Its amorphous forms have low melting and boiling point compared to crystalline forms.
- ❖ Carbon is insoluble in water and other common solvents. But some of its compounds are soluble in water and other solvents. e.g., Ethanol,  $CO_2$  are soluble in water.

## 15.5 Chemical properties of Carbon and its compounds

Elemental carbon undergoes no reaction at room temperature and limited number of reactions at elevated temperatures. But its compounds undergo large number of reactions even at room temperature.

## Oxidation – (Reaction with oxygen)

Carbon combines with oxygen to form its oxides like carbon monoxide (CO) and carbon dioxide (CO<sub>2</sub>) with evolution of heat. Organic carbon compounds like hydrocarbon also undergo oxidation to form oxides and steam with evolution of heat and flame. This is otherwise called combustion.

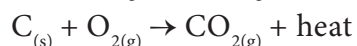
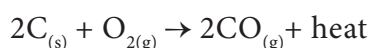

## Reaction with steam

Carbon reacts with steam to form carbon monoxide and hydrogen. This mixture is called water gas.

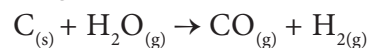

## Reaction with sulphur

With sulphur, carbon forms its disulphide at high temperature.

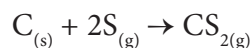

## Reaction with metals

At elevated temperatures, carbon reacts with some metals like iron, tungsten, titanium, etc. to form their carbides.

Tungsten + Carbon → Tungsten carbide

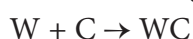

## 15.6 Carbon compounds in everyday life

It is impossible to think of our daily life without carbon compounds. Over time, a large number of carbon compounds have been developed for the improvement of our lifestyle and comfort. They include carbon-based fuels, carbon nanomaterials, plastics, carbon filters, carbon steel, etc.

Even though carbon and its compounds are vital for modern life, some of its compounds like CO, cyanide and certain types of plastics are harmful to humans. In the following segment, let us discuss the role of plastics in our daily life and how we can become aware of the toxic chemicals that some plastics contain.

## 15.7 Plastics – Catenated long chain carbon compounds

Plastics are a major class of catenated organic carbon compounds. They are made from long chain organic compounds called ‘polymer resins’ with chemical additives that give them different properties. Different kinds of polymers are used to make different types of plastics. Plastics are everywhere. They are convenient, cheap and are used in our everyday life. Plastics have changed the way we live. They have helped improve health care, transport and food safety. Plastics have allowed many breakthroughs in technologies such as smartphones, computers and the internet. It is clear that plastic has given our society many benefits. But these benefits have come at a cost.

### 15.7.1 Drawbacks of plastics

- ❖ Plastics take a very long time to fully break down in nature.
- ❖ The microbes that break down plastic are too few in nature to deal with the quantity of plastics we produce.
- ❖ A lot of plastic does not get recycled and ends up polluting the environment.
- ❖ Some types of plastics contain harmful chemical additives that are not good for human health.
- ❖ Burning of plastics releases toxic gases that are harmful to our health and contribute to climate change.
- ❖ One-time use and throwaway plastics end up littering and polluting the environment.

In order to know which plastics are harmful, you will need to learn the secret ‘language’ of plastics (resin codes).

### 15.7.2 Identifying different types of plastics

#### (a) The resin codes

Look at the following pictures. One is a plastic sachet in which milk is distributed

to consumers and the other is a plastic food container. Observe the code shown on it (circled). Do you know what this code means? It is called a 'resin code'. The resin code represents the type of polymer used to make the plastic.



Figure 15.3 Plastic items used in daily life

### (b) Need for resin codes

Plastics should be recycled or disposed of safely. Certain types of plastics should be avoided so that they do not end up polluting the environment or harming our health. Each plastic is composed of a different polymer or set of molecules. Different molecules do not mix when plastics are recycled, it is like trying to recycle paper and glass together. For this reason, they need to be separated. The resin codes of plastics were designed in 1988 and are a uniform way of classifying the different types of plastic which help recyclers in the sorting process.

### (c) Find in the resin code on plastic items

The secret resin codes are shown as **three chasing arrows in a triangle**. There is a **number in the middle or letters under the triangle** (an acronym of that plastic type). This is usually difficult to find. It can be found on the label or bottom of a plastic item.

The resin codes are numbered from 1 to 7. Resin codes #1 to #6 each identify a certain type of plastic that is often used in products. Resin code #7 is a category which is used for every other plastic (since 1988) that does not fit into the categories #1 to #6. The resin codes look very similar to the recycling symbol, but this does not mean that all plastics with a code can be recycled.



Figure 15.4 Resin codes

### (d) Where will the resin code be shown on plastic items?

Flip a plastic item to find the resin code on the bottom.



Sometimes the bottom of plastic item will only have an acronym or the full name of that plastic type.



If you do not find it on the bottom, search for the code on the label.



Some plastics do not have a code. The company did not follow the rules and you do not know if it is safe to use.



### 15.7.3 Harmful effects of plastics

Plastics in our everyday life can be harmful for two reasons. The first reason is that some types of plastic contain chemicals that are harmful to our health. The second reason is that a lot of plastics are designed to be used just for one time. This use and throwaway plastic causes pollution to our environment.

#### (a) Harmful plastics

There are three types of plastic that use toxic and harmful chemicals. These chemicals are added to plastics to give them certain qualities such as flexibility, strength, colour and fire or UV resistance. The three unsafe plastics are: PVC (resin code #3), PS (resin code #6 also commonly called Thermocol) and PC/ABS (resin code #7).

#### PVC – Polyvinyl Chloride plastics

- Heavy metals (cadmium & lead) are added to PVC.
- Phthalates (chemical additive) copy our hormones.
- Burning PVC releases dioxins (one of the most toxic chemicals known to humans).



#### PS – Polystyrene plastics

- Styrene is a building block of this plastic and may cause cancer.
- It takes very long time to break-down (100- 1 million years).
- Higher amounts of toxic styrene leak into our food and drinks when they are hot or oily.



#### PC – Polycarbonate plastics

- PC plastic contains Bisphenol A (BPA).
- BPA leaks out of PC products used for food and drinks.
- BPA increases or decreases certain hormones and changes the way our bodies work.

#### ABS – Acrylonitrile Butadiene Styrene

- Styrene causes problems for our eyes, skin, digestive system and lungs.
- Brominated Flame Retardants (BFRs) are often added.
- Studies show that toxic chemicals leak from this plastic.



#### (b) One-time use plastic

Use and throwaway plastics cause short and long-term environmental damage. Half of all the plastic made today is used for throwaway plastic items. These block drains and pollute water bodies. One-time use plastic causes health problems for humans, plants and animals. Some examples are plastic carry bags, cups, plates, straws, water pouches, cutlery and plastic sheets used for food wrapping.



Figure 15.5 One-time use plastic items

These items take a few seconds to be made in a factory. You will use them for a very short time. Once you throw them away, they can stay in our environment for over a 1,000 years causing plastic pollution for future generations. We need rules and laws to protect people and the environment from plastic pollution.

## 15.8 New rules to make Tamil Nadu plastic free

As we know, the Government of India is progressively taking various legal initiatives to stop plastic pollution by making some



provisions and amendments in the Environment (Protection) Act, 1988. With reference to this act, Government of Tamil Nadu has taken a step forward to ban the usage of some kind of plastic items (Environment and Forests Department, T.N. G.O. No: 84, dated 25/06/2018).

As per the government order cited above, the Tamil Nadu Government has banned the usage of one-time use and throwaway plastics from 1<sup>st</sup> January 2019. This excellent legislation is designed to protect Tamil Nadu from plastic pollution.

Rules which ban the production, storage, supply, transport, sale and distribution of one-time use plastics are extremely effective. They are successful because they target all sections of society—manufacturer, supplier, shopkeeper and customer. This progressive initiative taken by the State of Tamil Nadu leads by example for the rest of the nation.

You can find below some key aspects of the new rules along with science-based facts why these items have been banned in Tamil Nadu.

### 15.8.1 Banned items

#### Plastic carry bags

- Globally we use 2 million plastic bags each minute.
- 97% of plastic bags do not get recycled.
- Animals eat plastic bags by accident as they contain food. A cow was found with over 70 kilos of plastic in its stomach.

#### Plastic plates

- Dirty plastics (like a used plate) are difficult to recycle.
- Most of the one-time use plates are made from Polystyrene (resin code # 6) which is harmful to our health.
- Plates will be used for just 20 minutes but stay in the environment for over a 1,000 years.

#### Water pouches

- Water pouches are often littered, increasing plastic pollution.

- The blue print (ink) on the clear plastic pouch decreases the recycling value.
- Once a water pouch is used, it is difficult to recycle as it contains leftover water and gets covered in dirt.

#### Plastic straws

- Plastic straws are too light and small to be recycled.
- Straws are one of the top 10 items which are found in the plastic pollution in oceans.
- 90% of seabirds have ingested plastics such as straws.

#### Plastic sheets

- Plastic sheets used on top of plates get dirty and cannot be recycled.
- More chemicals leak from plastic into food when it is hot, spicy or oily.
- Animals such as cows, goats, and dogs eat plastic by accident because it smells like food.

## 15.9 Role of students in the prevention of plastic pollution

You play a very important role and have the power to minimise plastic pollution. Ask yourself, is this plastic safe or harmful plastic? If it is not a harmful plastic type, is it a one-time use plastic item? These questions and the science-based knowledge will help you to reduce unnecessary plastic pollution.

### 15.9.1 What can you do to prevent plastic pollution?

- As a student, you can share your scientific knowledge on plastics and their effects with your parents, relatives and friends to make them aware of plastic pollution.
- You can help by teaching them how to avoid harmful plastics by searching for the resin codes.
- You can educate them about the new rules and how important it is to stop one-time use plastics.

### 15.9.2 Practice in your daily life

- Do not litter the environment by throwing plastic items.
- Do not use Thermocol (resin code #6 PS) for your school projects.
- Do not use one-time use or throwaway plastics like plastics bags, tea cups, Thermocol plates and cups, and plastic straws.
- Do not burn plastics since they release toxic gases that are harmful to our health and contribute to climate change.
- Burning PVC plastic releases dioxins which are one of the most dangerous chemicals known to humans.
- Do not eat hot or spicy food items in plastic containers.
- Segregate your plastic waste and hand this over to the municipal authorities so that it can be recycled.
- Educate at least one person per day about how to identify the resin codes and avoid unsafe plastics (resin code #3 PVC, #6 PS and #7 ABS/PC).

#### Points to Remember

- ❖ Carbon is an inseparable chemical entity associated with living things.
- ❖ Carbon chemistry is also called as living chemistry.
- ❖ Carbon is found both in free state as well as combined state in nature.
- ❖ Friedrich Wohler is called Father of Modern Organic Chemistry.
- ❖ Carbon atom links repeatedly to itself through covalent bond to form linear chain, branched chain or ring structure.
- ❖ Charcoal, graphite and diamond are the allotropes of carbon.
- ❖ In diamond atoms are arranged in repeated tetrahedral fashion.
- ❖ All the allotropic forms of carbon are solids whereas its compounds exist in solid, liquid and gaseous state.
- ❖ The resin code represents the polymer used in making of plastics. The resin codes are numbered from 1 to 7.
- ❖ One-time use plastic causes health problems for humans, plants and animals.

### A-Z GLOSSARY

<b>Allotropes</b>	Different forms of an element.
<b>Allotropy</b>	Property by which an element can exist in more than one form.
<b>Catenation</b>	Binding of an element to itself or with other elements through covalent bonds.
<b>Harmful plastics</b>	Plastic in which toxic and harmful chemicals are used.
<b>Isomerism</b>	Phenomenon in which same molecular formula may exhibit different structural arrangement.
<b>Isomers</b>	Compounds that have same molecular formula but different structural formula.
<b>One-time use plastic</b>	Use and throwaway plastics.
<b>Organic carbon compounds</b>	Compounds of carbon obtained from living organisms.
<b>Plastics</b>	Major class of catenated organic carbon compounds made from liquid polymers called 'resins' added with some additives.
<b>Tetravalency</b>	Tendency of carbon to share its four electrons with that of other atoms to complete its octet.



## TEXTBOOK EXERCISES



### I. Choose the correct answer.

- A phenomenon in which an element exists in different modification in same physical state is called  
(a) isomerism (b) allotropy  
(c) catenation (d) crystallinity
- Carbon forms large number of organic compounds due to  
(a) Allotropy (b) Isomerism  
(c) Tetravalency (d) Catenation
- Nandhini brings his lunch every day to school in a plastic container which has resin code number 5. The container is made of  
(a) Polystyrene (b) PVC  
(c) Polypropylene (d) LDPE
- Plastics made of Polycarbonate (PC) and Acrylonitrile Butadiene Styrene (ABS) are made of resin code \_\_\_\_\_  
(a) 2 (b) 5 (c) 6 (d) 7
- Graphene is one atom thick layer of carbon obtained from  
(a) diamond (b) fullerene  
(c) graphite (d) gas carbon
- The legal measures to prevent plastic pollution come under the \_\_\_\_\_ Protection Act 1988.  
(a) Forest (b) Wildlife  
(c) Environment (d) Human rights

### II. Fill in the blanks.

- \_\_\_\_\_ named carbon.
- Buckminster Fullerene contains \_\_\_\_\_ carbon atoms.
- Compounds with same molecular formula and different structural formula are known as \_\_\_\_\_.
- \_\_\_\_\_ is a suitable solvent for sulphur.
- There are \_\_\_\_\_ plastic resin codes.

### III. Match the following.

- |               |   |             |
|---------------|---|-------------|
| 1. Alkyne     | - | Bucky Ball  |
| 2. Andre Geim | - | Oxidation   |
| 3. $C_{60}$   | - | Graphene    |
| 4. Thermocol  | - | Triple bond |
| 5. Combustion | - | Polystyrene |

### IV. Answer briefly.

- Differentiate graphite and diamond
- Write all possible isomers of  $C_4H_{10}$ .
- Carbon forms only covalent compounds. Why?
- Define Allotropy.
- Why are one-time use and throwaway plastics harmful?

### V. Answer in detail.

- What is catenation? How does carbon form catenated compounds?
- What are the chemical reactions of carbon?
- Name the three safer resin codes of plastics and describe their features.

### VI. Higher Order Thinking Skills

- Why do carbon exist mostly in combined state?
- When a carbon fuel burns in less aerated room, it is dangerous to stay there. Why?
- Explain how dioxins are formed? Which plastic type they are linked to and why they are harmful to humans?
- Yugaa wants to buy a plastic water bottle. She goes to the shop and sees four different kinds of plastic bottles with resin codes 1, 3, 5 and 7. Which one should she buy? Why?



## REFERENCE BOOKS

- Modern Inorganic Chemistry by R.D Madan
- Fundamentals of Organic Chemistry by B.S.Bahl et.al
- Organic Chemistry by Paula Bruise, 6th Edition



## INTERNET RESOURCES

<http://www.chemcool.com/elements/carbon.html>

<https://en.wikipedia.org/wiki/Carbon>

<https://courses.lumenlearning.com/introchem/chapter/allotropes-of-carbon/>

<https://plastics.americanchemistry.com/Plastic-Resin-Codes-PDF/>

<https://www.youtube.com/watch?v=8Obb982Sg84>

## Concept Map

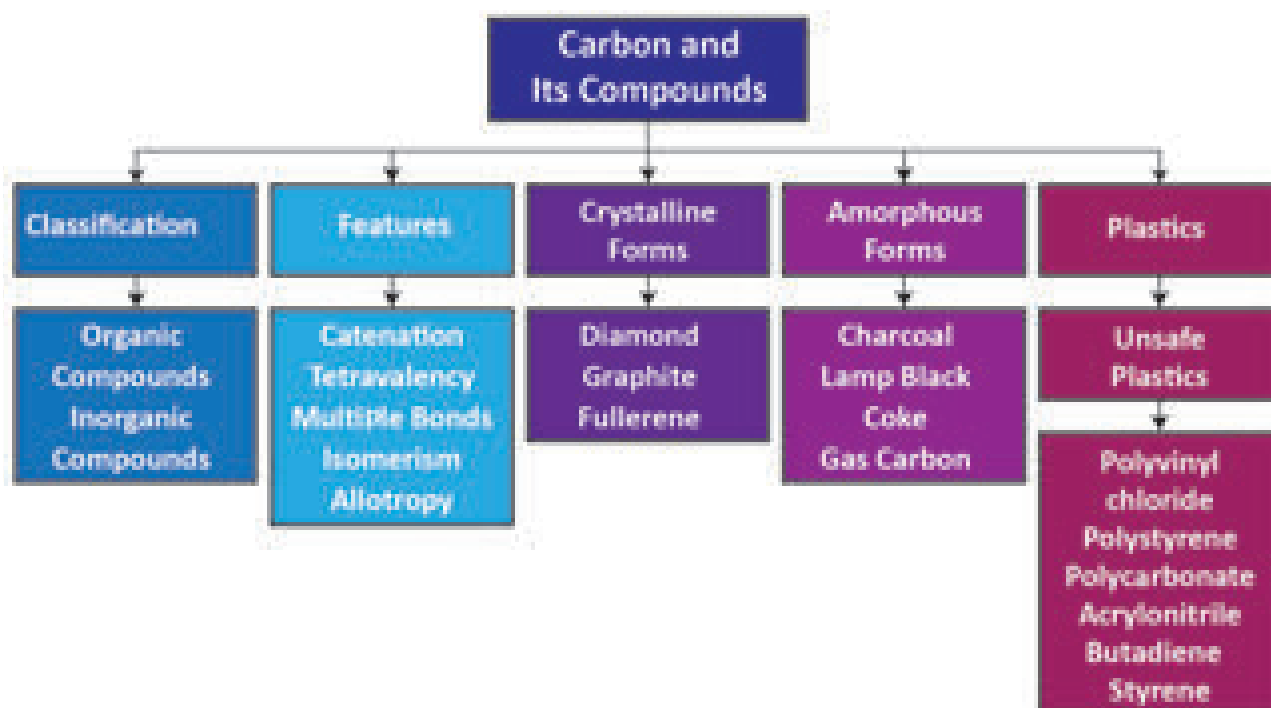

## ICT CORNER

## Carbon

### Steps

- Reach the given URL to download and install the “Avogadro” cross platform application in your computer.
- Open the Avogadro application and select carbon from “Element” tab and select the available bond type “Single” or “Double” or “Triple”.
- Place the mouse pointer on the black screen and click and drag the mouse to draw the carbon structure. Extend the bonding by dragging repeatedly. Build the structure of Ethane, Methane etc.
- Select “Auto Rotation” from the tools and rotate the molecular structure by dragging the mouse on the bond. To view various properties of the drawn bonding go to menu View -> Properties.

### Avogadro

URL: <https://avogadro.cc/> or Scan the QR Code.



B567\_9\_SCI\_EM\_T3



## Learning Objectives

After completing this lesson, students will be able to:

- understand the various branches of applied chemistry.
- know the technology of Nanochemistry.
- know the various types of drugs.
- understand the various uses of electrochemistry.
- understand the applications of radiochemistry.
- understand various types of dyes and their application.
- acquire knowledge about food chemistry and agricultural chemistry.
- understand some basic ideas about forensic chemistry.

## Introduction

Food, medicines, cosmetics, dress materials and gold covering ornaments are some of the items used in our day to day life. They may differ in nature and applications. But all these are associated with chemistry. They are made of synthetic / natural chemicals.

We face a lot of difficulties in different means to lead our day to day life. Such difficulties make chemists come up with new ideas and theories. For example, when people suffered from diseases, new chemical compounds were synthesized and used as drugs. New techniques were also developed to diagnose diseases. When farmers suffered due to low crop yield and pest-related problems in crop fields, chemists developed new chemical fertilizers and pesticides to combat these issues. Thus chemical principles and theories are applied to various fields in order to achieve specific results

or to solve real-world problems. This is called **applied chemistry**. In this lesson, let us discuss various branches of applied chemistry and their significance.

## 16.1 Nanochemistry

We know that the size and shape of materials influence their characteristics. Scientists found that materials having size about  $1/1,000,000,000$  metre show special characteristics. Then they started producing such kind of materials and studied the effect of size on properties. Thus a new branch of chemistry called 'Nanochemistry' was developed.

Nanochemistry is a branch of nanoscience, that deals with the chemical applications of nanomaterials in nanotechnology. It involves synthesis and manipulation of materials at atomic and molecular level and the study of their physical and chemical properties.

### 16.1.1 Size of Nanoparticles

The word, Nano has been derived from the Greek word 'Nanos' which is designated to represent billionth fraction of a unit. For instance, 1 Nanometre = 1/ 1,000,000,000 metre. Can you imagine how small is a nanoparticle?

The following examples may help to illustrate how small the nanoscale is.

- One nanometre (nm) is  $10^{-9}$  or 0.000,000,001 metre.
- A nanometre and a metre can be understood as the same size-difference as between golf ball and the Earth.
- Our nails grow 1 nm each second.
- The virus most usually responsible for the common cold has a diameter of 30 nm.
- A cell membrane is around 9 nm across.
- The DNA double helix is 2 nm across.
- The diameter of one hydrogen atom is around 0.2 nm.

### 16.1.2 Properties of nanomaterials

Nanomaterials have the structural features in between those of atoms and the bulk materials. The properties of materials with nanometre dimensions are significantly different from those of atoms and bulk materials. This is mainly because the nanometre size of the materials render them, larger surface area, high surface energy, spatial confinement and reduced imperfections, which do not exist in the corresponding bulk materials. As the surface characteristics of nanoparticles are the main criteria to be considered for applications, highly sophisticated instruments like Scanning Electron Microscope (SEM), Tunneling Electron Microscope (TEM) and Atomic Force Microscope (AFM) are used to analyse the surface properties of a nanoparticle with high resolution.

### 16.1.3 Applications of Nanochemistry

The range of commercial products available today is very broad, including stain-resistant and wrinkle-free textiles, cosmetics, sun screens, electronics, paints and varnishes. Nanochemistry is applied in all these substances. Some of them are given below.

- The metallic nanoparticles can be used as very active catalysts.
- Nano coatings and nanocomposites are found useful in making variety of products such as sports equipment, bicycles and automobiles etc.
- Nanotechnology is applied in the production of synthetic skin and implant surgery.
- Nanomaterials that conduct electricity are being used in electronics as minute conductors to produce circuits for microchips.
- Nanomaterials have extensive applications in the preparation of cosmetics, deodorants and sun screen lotion.
- Nanoparticle substances are incorporated in fabrics to prevent the growth of bacteria.
- Nanochemistry is used in making space, defence and aeronautical devices.

### 16.1.4 Drawbacks of nanomaterials in chemistry

- Nanoparticles are unstable when they react with oxygen.
- Their exothermic combustion with oxygen can easily cause explosion.
- Because nanoparticles are highly reactive, they inherently interact with impurities as well.
- Nanomaterials are biologically harmful and toxic.
- It is difficult to synthesis, isolate and apply them.
- There are no hard-and-fast safe disposal policies for nanomaterials.

## 16.2 Pharmaceutical chemistry

Pharmaceutical chemistry is the chemistry of drugs which utilizes the general laws of chemistry to study drugs. Pharmaceutical chemistry deals with preparation of drugs and the study of chemical composition, nature, behavior, structure and influence of the drug in an organism, condition of their storage and the therapeutic uses of the drugs. Drug discovery is the core of pharmaceutical chemistry.

### 16.2.1 Drugs

Even though we use so many chemicals in our daily life, the chemicals used for treating diseases are termed as **drug**. The word drug is derived from the French word 'drogue' which means a dry herb.

According to World Health Organisation, a drug is defined as follows: 'It is a substance or product that is used or intended to be used to modify or explore physiological systems or pathological states for the benefits of the recipient'.

### 16.2.2 Characteristics of drugs

A drug must possess the following characteristics:

- It should not be toxic.
- It should not cause any side effects.
- It should not affect the receptor tissues.
- It should not affect the normal physiological activities.
- It should be effective in its action.

### 16.2.3 Sources of drugs

The main sources of drugs are animals and plants. The modern manufacturers adopt many chemical strategies to synthesize drugs for specialized treatments which are more uniform than natural materials. The following table shows various sources of drugs.

Table 16.1 Sources of drugs

Source or Process	Drug
Plants	Morphine, Quinine
Chemical Synthesis	Aspirin, Paracetamol
Animal	Insulin, Heparin
Minerals	Liquid Paraffin
Microorganism	Penicillin
Genetic Engineering	Human growth Hormone

### 16.2.4 Types of Drugs

Drugs fall into two general categories:

- i) The drugs that are used in the treatment and cure of any specific disease.
- ii) The drugs that have some characteristic effect on the animal organism, but do not have any remedial effect for a particular disease. This class includes, morphine, cocaine etc.

#### 1. Anaesthetics

The drugs which cause loss of sensation are called **Anaesthetics**. They are given to patients when they undergo surgery.

##### (a) Types of Anaesthetics

When patients undergo a major surgery in internal organs, some anaesthetics are given so that they lose sensation completely. But when they undergo a minor surgery in a specific part of the body, anaesthetic is given to lose sensation around that particular part. Based on this, there are two classes of anaesthetics as given below.

**General anaesthetics:** They are the agents, which bring about loss of all modalities of sensation, particularly pain along with 'reversible' loss of consciousness. For example, when a surgery is carried out on internal organs, these anaesthetics are given. The patient loses consciousness for specific period of time (depending on the duration of surgery) and get it back later.

**Local anaesthetics:** They prevent the pain sensation in localised areas without affecting the

degree of consciousness. For example, dentist give patients this kind of anaesthetics when carry out a minor surgery in teeth.

#### (b) Chemicals as Anaesthetics:

There are three major chemicals which are used as anaesthetics. They are:

**Nitrous Oxide (N<sub>2</sub>O):** It is a colourless, non-irritating, inorganic gas. It is the safest of the anaesthetic agents. This is used after mixing general anaesthetics like ether.

**Chloroform (CHCl<sub>3</sub>):** It is a volatile liquid. It has pleasant smell and sweet taste. With oxygen it forms a toxic carbonyl chloride. Hence it is not used now.

**Ether:** Diethyl ether or simple ether (C<sub>2</sub>H<sub>5</sub>-O-C<sub>2</sub>H<sub>5</sub>) is a volatile liquid. This is mixed with a stabilizer, 0.002% propyl halide. After absorption by tissues it attacks the central nervous system and makes the patient unconscious.

### 2. Analgesics

Analgesics are the compounds which relieve all sorts of pains without the loss of consciousness. These are also called as *pain killer* or *pain relievers*. These are effective in healing headaches, myalgia and arthralgia.

Aspirin and Novalgin are the commonly used analgesics. Aspirin acts both as antipyretic as well as analgesic. Certain narcotics (which produce sleep and unconsciousness) are also used as analgesics. The analgesics are given either **orally or applied externally**. In general, externally applicable pain killers come as 'gels'.

### 3. Antipyretics

Antipyretics are the compounds which are used for the purpose of reducing fever (lowering the body temperature to the normal). They are taken orally as tablets and capsules. The most common antipyretics are, aspirin, antipyrine, phenacetin, and paracetamol.

### 4. Antiseptics

Antiseptic is a substance that prevents infections caused by disease causing microorganisms or pathogens. Antiseptics either kill the micro-organism or prevent their growth. Antiseptics are used externally to cleanse wounds and internally to treat infections of the intestine and bladder.

- Iodoform (CHI<sub>3</sub>) is used as an antiseptic and its 1% solution is a disinfectant.
- 0.2 % solution of phenol acts as an antiseptic and its 1% solution is a disinfectant.
- Hydrogen peroxide is a minor antiseptic mainly used for cleansing wounds.

### 5. Antimalarial

Malaria is a vector borne disease which causes shivering and fever. It raises the body temperature to 103-106 °F. It causes **physical weakness** with the side-effects in liver and also causes **anemia**.

Extracts of roots and stems of certain plants are extensively used as antimalarial. Quinine is a natural antimalarial obtained from Cinchona bark. The last antimalarial discovered in 1961 is pyrimethamine. However, quinine, primaquine and chloroquine are some of the best antimalarials. Chloroquine is used specially to control malarial parasites such as plasmodium ovale, plasmodium vivax etc. It is not used in curing the disease. It is used as an additive with other antimalarial drugs.



**Figure 16.1** Cinchona Bark



## 6. Antibiotics

Many microorganisms (bacteria, fungi and molds) produce certain chemicals which inhibit the growth or metabolism of some other disease causing micro organisms. Such chemical compounds are known as *antibiotics*. These need to be present only in low concentration to be effective in their antibiotic action. The first antibiotic 'penicillin' was discovered by Alexander Fleming in 1929, from the mold *Penicillium notatum*. Penicillin is extensively used for rheumatic fever, narrowing of heart wall, bronchitis, and pneumonia etc.

There are three main sources of antibiotics: (i) Bacteria (ii) Fungi and (iii) Actinomycetes. The original antibiotics, like a lot of today's antibiotics, are derived from natural sources. Certain plant extracts, essential oils, and even foods have antibiotic properties. Example: Honey, garlic, ginger, clove, neem and turmeric.

## 7. Antacids

Quite often, after eating oily and spicy food, one may feel uncomfortable due to some burning sensation in stomach / food pipe. This is due to imbalance in the acidity in the stomach. Certain drug formulations provide relief from such burning sensation. These are known as **antacids**. Antacids are available in tablet as well as gel / syrup forms. These antacids contain magnesium and aluminium hydroxides, in addition to flavouring agents and colour.

## 16.3 Electrochemistry

We use so many electronic devices like mobile phone, and electrical devices like torch light, in our daily life. Electricity produced by the battery is the key factor which makes these devices to function. But how does battery produce electricity? Because it contains some chemicals in it. The chemical reactions (chemical energy) that take place in the battery

produce electricity (electrical energy). So, when scientists realized that chemical energy can be converted into electrical energy and vice versa, another branch of applied chemistry was developed. It is **Electrochemistry**.

**Electrochemistry** is a branch of chemistry which deals with the relation between electrical energy and chemical change. It is mainly concerned with the processes taking place between the electrode and solution having ions called **electrolyte**.

### 16.3.1 Electrochemical Cell

So many chemical reactions take place around us. Do all they produce electricity? No. Only redox reactions that take place in a specific device can produce electricity. The device that make use of a chemical change to produce electricity or electricity to produce chemical change is called **Electrochemical Cell**.

#### (a) Components of Electrochemical Cell

An electrochemical cell may comprise of the following two major components.

**Electrode:** It is a solid electrical conductor made of metal (sometimes non-metal like graphite). A cell consists of two electrodes. One is called **Anode** and the other is called **Cathode**.

**Electrolyte:** It is made up of solutions of ions or molten salts which can conduct electricity.

#### (b) Cell reactions

An electrochemical cell involves two reactions simultaneously.

**Oxidation:** As we know already, an oxidation is **loss of electron**. In electrochemical cells, oxidation takes place at anode.



**Reduction:** It involves gain of electron. Reduction takes place at cathode



Since both the reactions take place simultaneously, the interconversion of electrical and chemical energy in electrochemical cells involves a **redox reaction**.

### (c) Types of Electrochemical Cell

Based on the nature of the energy conversion, electrochemical cells are broadly classified as below.



#### Galvanic Cell

- It is an electrochemical cell which converts chemical energy into electrical energy i.e. it produces electricity from chemical reactions.
- It consists of two half cells namely **anodic half-cell** and **cathodic half-cell**.
- In anodic half-cell, the anode is in contact with its electrolyte whereas in cathodic half-cell, the cathode is in contact with its electrolyte.
- The anode and cathode are connected by a conductor wire. The electrolytes of half-cells are connected through a tube containing a saturated salt solution. It is called **salt bridge**. Thus in galvanic cell, both the half-cells are kept separately but stay connected electrically.

#### How does a galvanic cell produce electricity?

At anode, oxidation takes place which releases electrons. These electrons are attracted by cathode and hence the electrons flowing from anode to cathode are gained in reduction reaction. As long as the redox reaction proceeds, there is a flow of electrons and hence electricity.

#### Activity 1

With the help of your teacher, construct the galvanic cell using lemon and potato. Identify their anode, cathode and electrolyte.

#### Electrolytic Cell

- It is an electrochemical cell which converts electrical energy into chemical energy i.e. in electrolytic cells, electricity is used to bring about chemical reactions.
- Here, both anode and cathode are in contact with same electrolyte and thus the half-cells are not separated. As seen in galvanic cells, electrolytic cell also involves redox reaction.

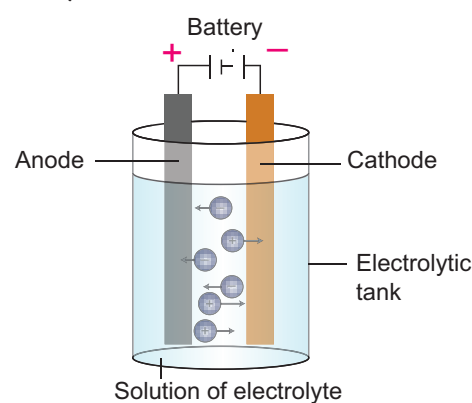

**Figure 16.2** Electrolytic Cell

We get electricity from galvanic cells. But electrolytic cells use electricity. Then how are they useful?

In electrolytic cells, when electricity is passed to the electrolyte, it dissociates into its constituent ions. These ions undergo redox reaction forming the respective elements. This phenomenon is called **Electrolysis**. So, electrolysis is a process by which an electrolyte is decomposed into its constituent elements by passing electricity through its aqueous solution or fused (molten) state.

#### (b) Significance of electrochemistry

The subject of electro chemistry is of great significance. Some of its applications are given below.

- It has been used to discover important technical processes for the production and purification of non-ferrous metals, and for the electro-synthesis of organic compounds.
- Electrochemistry is used to predict whether a particular reaction will occur or not.

- iii. The detection of alcohol in drunken drivers is possible through the electrochemical redox reaction of ethanol.
- iv. Production of metals like aluminum and titanium from their ores involve electrochemical reactions.
- v. Lead acid batteries, lithium-ion batteries and fuel cells are based on electrochemical cells. Fuel cell is used to bring about direct conversion of chemical energy into electrical energy.

## 16.4 Radiochemistry

You have studied in previous chapters that elements can exist in nature as their isotopes. Isotopes are atoms with same number of protons and electrons and a different number of neutrons. Some isotopes are stable and stay forever. These are the elements that we see around us and find in nature. However, some isotopes are unstable and they undergo disintegration by losing their energy in the form of radiation. As we studied earlier, every element tries to attain stability by sharing, losing or gaining electrons (octet rule). Thus, the unstable isotopes of elements lose their energy in the form of radiation to become stable.

This phenomenon is called **radioactive decay**. The isotope which undergoes radioactive decay is called **radioactive isotope** or **radioisotope**. This property of isotopes is known as **radioactivity**.



Uranium in the ground can decay into radon gas which can be very dangerous to humans. It is thought to be the second leading isotope to cause lung cancer.

**Radiochemistry** is the study of chemistry of radioactive and non-radioactive isotopes. It includes both natural and artificial isotopes. Radiochemistry mainly deals with application of radioisotopes to study the nature of chemical reactions of non-radioactive isotopes of

elements and applications of radioisotopes to various fields.

### 16.4.1 Applications of Radiochemistry

Radioisotopes can easily be detected and estimated quantitatively. So they are used in radiochemistry for various applications. Radiochemistry mainly deals with study of chemical reactions of non-radioactive isotopes using radioisotopes. In addition to that it could find applications in medical field and environmental management also. Let us list important applications of radioisotopes.

**Radiocarbon dating:** It is a method by which the age of fossil wood or animal is determined using C-14 isotope.

**Diagnosis:** Radioisotopes are found very useful to diagnose and understand many diseases.

**Table 16.2** Radioisotope in Diagnosis

Radioisotope	Diagnosis used for
Iodine-131	Location and detection of brain tumor, thyroid gland disorder.
Sodium-24	Location of blood clot and circulation disorders, pumping action of heart.
Iron-59	Diagnosis of anaemia, pregnancy disorder.
Cobalt-60	Diagnosis of cancer.
Hydrogen-3	Water content of the human body.

**Radiotherapy:** Radioactive isotopes are used in the treatment of many diseases. This kind of treatment is called radiotherapy.

**Table 16.3** Radioisotope in Treatment

Radioisotope	Treatment used for
Gold-198	Cancer
Iodine-131	Hyperthyroidism and cancer
Phosphorous-32	Blood disorder and skin disease
Cobalt-60	Cancer

## 16.5 Dye Chemistry

Human is always fascinated by colours, because we are living in a colourful world. We could see so many colours in plants and their flowers. We eat coloured food stuffs and use numerous coloured materials in our daily life. Do you know how do they get coloured? Because they contain some kind of chemicals in them which are called colourants.

The uses of colourants by mankind for painting and dyeing dates back to the dawn of civilization. Until the middle of the 19th century, all colourants applied were from natural origin. For example, inorganic pigments such as soot, manganese oxide, hematite were used as colourants. Organic natural colourants have also a timeless history of application, especially for colouring textiles. The organic compounds that are used as colourants are called **dyes**. These dyes are all aromatic compounds, originating from plants and also from insects, fungi and lichens.

After the evolution of modern organic chemistry, many kinds of synthetic dyes were prepared and used by mankind. **Dye chemistry** is the study of such kind of dyes. It provides us information on theory, structure, synthesis and applications of synthetic dyes.

### 16.5.1 Characteristics of Dyes

All coloured compounds are not dyes. Dyes are those coloured compounds which can be firmly fixed in fabrics by chemical or physical bonding. So, a dye should have the following characteristics:

- It should have a suitable colour.
- It should be able to fix itself or be capable of being fixed to the fabric.
- It should be fast to light.
- It should be resistant to the action of water, dilute acids and alkalies.

### 16.5.2 Classification of dyes

Now a days, practically all the dyes are synthetic, and are prepared from aromatic

compounds obtained from coal tar. Therefore, such dyes are sometimes called as coal tar dyes. But, they may differ in their basic structure and the way of application. So, dyes are classified in two ways: one, based on the method of application and other based on their parent structure.

#### (a) Based on method of application

**Acid dyes:** These are acidic in nature and used for dyeing animal fibres and synthetic fibres. These can be used for protein fibres such as wool and silk. E.g. Picric acid, Naphthol yellow-s

**Basic dyes:** These are basic dyes containing basic group ( $-\text{NH}_2$ ,  $-\text{NHR}$ ,  $-\text{NR}_2$ ). They are used for dyeing animal fibres and plant fibres.

**Mordant dyes or Indirect dyes:** These dyes have a poor affinity for cotton fabrics and hence do not dye directly. They require pretreatment of the fibre with a mordant. Mordant (latin : mordere = to bite) is a substance which can be fixed to the fibre and then can be combined with the dye to form an insoluble complex called lake. Aluminium, chromium, and iron salts are widely used as mordants. E.g. alizarin.

**Direct dyes:** They have high affinity for cotton, rayon and other cellulose fibre. So, they are applied directly as they fix firmly on the fabric. E.g. Congo red

**Vat dyes:** It can be used only on cotton and, not on silk and wool. This dyeing is a continuous process and is carried out in a large vessel called vat. So, it is called as vat dye. E.g. Indigo



Figure 16.3 Vat dyes

## (b) Based on Structure

Based on the structure, dyes are classified as:

- Azo dyes
- Diphenyl methane dye
- Triphenyl methane dye
- Phthalein dye
- Anthraquinone dye
- Indigo dyes
- Phthalo cyanine dye
- Nitro and nitroso dyes

## 16.6 Agricultural and Food Chemistry

### 16.6.1 Agricultural Chemistry

Agricultural chemistry involves the application of chemical and biochemical knowledge to agricultural production, processing of raw materials into foods and beverages, and environmental monitoring and remediation. It deals with scientific relation between plants, animals, bacteria and environment.

#### (a) Goals of agricultural chemistry

Indian chemists and biochemists applied their knowledge and developed modernized agricultural practices which involve use of synthetic fertilizers, genetically modified crops, and equipments. It aims at producing sufficient nutritious food and feed the population in a sustainable way while being responsible stewards of our environment and ecosystem. Based on the issues and challenges in agricultural production, agricultural chemistry mainly focusses to achieve the following:

- Increase in crop yield and livestock
- Improvement of food quality
- Reducing cost of food production

#### (b) Applications of Agricultural Chemistry

Chemical principles and reactions are most widely used in agriculture in order to increase yield, to protect crops from diseases and to simplify the practice of agriculture. Various applications are give below.

**Soil Testing:** Crop lands may have different kinds of soil with varying pH. Soil pH is one of the main criteria to be considered for the selection of crop or remediation of soil. Soil testing involves determination of pH, porosity and texture.

**Chemical Fertilizers:** Fertilizers are chemical compounds added to crop field for supplying essential micro and macro nutrients required for crop growth. Ammonium nitrate, calcium phosphate, urea, NPK (Nitrogen, Phosphorous and Potassium), etc. are some of the fertilizers. Depending on the nature of soil, these fertilizers are used singly or as mixtures.

**Pesticides and Insecticides:** Crops are prone to diseases caused by pests and insects. Chemically synthesized pesticides and insecticides are used to solve these issues. Chlorinated hydrocarbons, organophosphates and carbamates are used as pesticides and insecticides.

### 16.6.2 Food Chemistry

Food is one of the basic needs of human and animal. The food we eat also are made of chemicals. Any human might require the following three kinds of food:

**Body building foods:** These are required for physical growth of body. E.g. Proteins

**Energy giving foods:** These are the foods that supply energy for the functioning of parts human body. E.g. Carbohydrates and Fats.

**Protective foods:** These protect us from deficiency diseases. E.g. Vitamins and Minerals

Every human requires all these three kind of foods in right proportion for the smooth functioning of the body. The diet that contain all these three foods in right proportion is called **Balanced diet**.

Food chemistry is the chemistry of foods which involves the analysis, processing, packaging, and utilization of materials including bioenergy for food safety and quality.

### (a) Goals of food chemistry

The main goal of food chemistry is to cater the needs of quality food to the population in a sustainable way. In basic research, food chemists study the properties of proteins, fats, starches, and carbohydrates, as well as micro components such as additives and flavourants, to determine how each works in a food system. In application research, they often develop new ways to use ingredients or new ingredients altogether, such as fat or sugar replacements.

### (b) Chemicals in Food

Food we eat in our day to day life contains natural or synthetic chemicals. They serve different functions in human body.

**Nutrients:** They are the most essential chemicals present in food. They are required for the growth, physiological and metabolic activities of body. They are natural or synthetic. E.g. Carbohydrates, proteins, vitamins and minerals.

**Food additives:** These are the chemicals added to food for specialized functions. The various types of additives of foods are given in Table 16.4.



40% of today's global population works in agriculture, making it the single largest employment in the world.

## 16.7 Forensic Chemistry

Forensic chemistry applies scientific principles, techniques, and methods to the investigation of crime. Our daily newspaper is carrying a lot of news on incidents of criminal activities such as robbery, murder, sexual harassment, etc. How the crime department investigate and analyse it? In real life the collection and analysis of evidence involve painstaking care and rigorous application of scientific principles.



Figure 16.4 Crime detection

### 16.7.1 Forensic Chemists in Criminal Investigation

In general, forensic chemists work in four steps in the investigation of crime.

**Collection of Evidences:** They collect physical evidences such as knife, instruments, materials, etc in a systematic way and uncover their information using chemistry.

**Analysis of evidences:** In criminal cases, chemists analyze substances such as blood and DNA to attempt to determine when and by whom the crime was committed.

Table 16.4 Food additives

Type of additive	Function of the additive	Example
Preservatives	They protect food from spoilage by microorganism in storage.	Vinegar, Sodium benzoate, benzoic acid, sodium nitrite
Colourants	They give pleasant colours to food	Carotenoids, Anthocyanin, Curcumin
Artificial Sweeteners	They add sweet taste to food	Saccharin, Cyclamate
Flavor enhancers	They are used to enhance the flavour of food items	Monosodium glutamate, Calcium diglutamate
Antioxidants	They prevent the oxidation of food. They protect us against cardiovascular disease.	Vitamin C, Vitamin E, Carotene

**Collaboration:** To solve the crime, they discuss with other fellow investigators like police officers, detective and other forensic scientists.

**Report of findings:** Finally, they prepare a report of the conclusion of the analysis.

### 16.7.2 Method of Forensic Chemistry

The world of forensic chemistry, focusing on the theory and processes of chemistry in forensic analysis shows the role that chemistry plays in criminal investigations. The following are some methods used in crime investigation by a forensic chemistry lab.

**Finger print:** Finger print is one of the most important evidences in crime investigation. Fingerprints on smooth surfaces can often be made visible by the application of light or dark powder, but fingerprints on cheque or other documents are often occult (hidden). Occult fingerprints are sometimes made visible by the use of ninhydrin, which turns purple due to reaction with amino acids present in perspiration. Fingerprints or other marks are also sometimes made visible by exposure to high-powered laser light. Cyanoacrylate ester fumes from glue are used with fluorescent dyes to make the fingerprints visible.



Figure 16.5 Finger print

**Biometrics:** The science that involves the study and analysis of human body prints is known as **biometrics**. The biometric system compares the body prints to the specimen data stored in the system to verify the identity of a person.

**Alcohol test:** Drinkers can be easily identified by the use of applied chemistry. The person being tested blows through a tube, which bubbles the breath through a solution of chemicals containing sulfuric acid, potassium dichromate, water, and silver nitrate. Oxidation of the alcohol results in the reduction of dichromate to chromic ion, with a corresponding change in colour from orange to green. An electrical device employing a photocell compares the colour of the test solution with a standard solution, giving a quantitative determination of the alcohol content. The test provides a quick and reproducible determination of the amount of alcohol in a person's breath and is a numerical measure of the amount of alcohol in the bloodstream.



Figure 16.6 Alcohol test

## 16.8 Applications of Applied Chemistry

- Many of the advantages of applied chemistry are around us. It is inevitable.
- Applied chemistry has given us innumerable synthetic materials to lead our day to day life.
- The applied chemistry makes a most important contribution to our society.
- It makes a major contribution to the country's economic development, and plays vital role worldwide.
- The products of applied chemistry are so widespread that they are used in our daily.

### Points to Remember

- ❖ Nanochemistry is a branch of nanoscience, that deals with the chemical applications of nanomaterials in nanotechnology.  
1 Nanometre = 1/ 1,000,000,000 metre.

- ❖ Pharmaceutical chemistry deals with the preparation of drugs and study of the chemical composition, nature, behavior, structure and influence of the drug in an organism.
- ❖ Electrochemistry is a branch of chemistry which deals with the relation between electrical energy and chemical change.
- ❖ Radiochemistry is the study of chemistry of radioactive and non-radioactive isotopes.
- ❖ Dye chemistry is the study of dyes. It provides us information on theory, structure, synthesis and applications of synthetic dyes.
- ❖ Agricultural chemistry involves the application of chemical and biochemical knowledge to agricultural production.
- ❖ Food chemistry is chemistry of foods which involves analysis, processing, packaging, and utilization of materials including bioenergy for food safety and quality.
- ❖ Forensic chemistry applies scientific principles, techniques, and methods to the investigation of crime.

## A-Z GLOSSARY

<b>Anaesthetics</b>	Drugs which cause loss of sensation.
<b>Antipyretics</b>	Compounds which are used for the purpose of reducing fever.
<b>Antiseptic</b>	Substance that prevents infections caused by disease causing microorganisms or pathogens.
<b>Antibiotics</b>	Chemical compounds which was produced by many microorganisms (bacteria, fungi and moulds) which inhibit the growth or metabolism of some other disease causing microorganism.
<b>Antacids</b>	These are certain drug formulations which provide relief from burning sensation.
<b>Drug</b>	The chemicals used for treating diseases
<b>Electrochemical Cell</b>	The device that make use of a chemical change to produce electricity or electricity to produce chemical change.
<b>Electrolyte</b>	Solutions of ions or molten salts which can conduct electricity
<b>Pharmaceutical Chemistry</b>	It is the study of drugs and it involves drug development.



## TEXTBOOK EXERCISES



### I. Choose the correct answer.

- One Nanometre is
  - $10^{-7}$  metre
  - $10^{-8}$  metre
  - $10^{-6}$  metre
  - $10^{-9}$  metre
- The antibiotic Penicillin is obtained from \_\_\_\_\_
  - plant
  - microorganism
  - animal
  - sunlight
- 1% solution of Iodoform is used as
  - antipyretic
  - antimalarial
  - antiseptic
  - antacid
- The cathode of an electrochemical reaction involves \_\_\_\_\_
  - oxidation
  - reduction
  - neutralisation
  - catenation



- The age of a dead animal can be determined by using an isotope of \_\_\_\_\_  
 (a) carbon (b) iodine  
 (c) phosphorous (d) oxygen
- Which of the following does not contain natural dyes?  
 (a) Potato (b) Beetroot  
 (c) Carrot (d) Turmeric
- This type of food protect us from deficiency diseases.  
 (a) Carbohydrates (b) Vitamins  
 (c) Proteins (d) Fats
- Radiochemistry deals with  
 (a) oxidants (b) batteries  
 (c) isotopes (d) nanoparticles
- The groups responsible for the colour of an organic compound is called  
 (a) isotopes (b) auxochrome  
 (c) chromogen (d) chromophore
- Chlorinated hydrocarbons are used as  
 (a) fertilizers (b) pesticides  
 (c) food colourants (d) preservatives

## II. Fill in the blanks.

- \_\_\_\_\_ is an electrochemical cell which converts electrical energy into chemical change(Reaction).
- Painkiller drugs are called \_\_\_\_\_
- Indigo is a \_\_\_\_\_ dye.
- \_\_\_\_\_, \_\_\_\_\_ and \_\_\_\_\_ are macronutrients required for plant growth.
- \_\_\_\_\_ is a chemical used in finger print analysis.

## III. Match the following.

Antipyretics	- Large surface area
Corrosion prevention	- Iodine-131
Hyperthyroidism	- Fever
Nanoparticle	- Body building
Proteins	- Electroplating

## IV. Answer briefly.

- What is Radio Carbon Dating?
- What are called Anaesthetics? How are they classified?
- What is the need for chemical fertilizers in crop fields?
- What is Forensic chemistry related to?

## V. Answer in detail.

- Explain the types of dyes based on their method of application.
- Name various food additives and explain their functions.

## VI. Higher Order Thinking Skills.

- Batteries that are used in mobile phone can be recharged. Likewise, can you recharge the batteries used in watches? Justify your answer.
- Sudha met with a fire accident. What kind of drug(s), she must take?
- The soil pH of a crop land is 5. What kind of fertilizers should be used in that land?



## REFERENCE BOOKS

- Nanomaterials and Nanochemistry by Catherine Brechignac
- Nuclear and Radiochemistry – Fundamentals and applications by Karl Heinrich Lieser
- Food Chemistry (Third Edition) by Owen Fennema



## INTERNET RESOURCES

[https://en.wikipedia.org/wiki/Agricultural\\_chemistry](https://en.wikipedia.org/wiki/Agricultural_chemistry)

<https://www.medicalnewstoday.com/articles/321108.php>

<https://www.youtube.com/watch?v=kC1aPOqoYWc>

# Concept Map

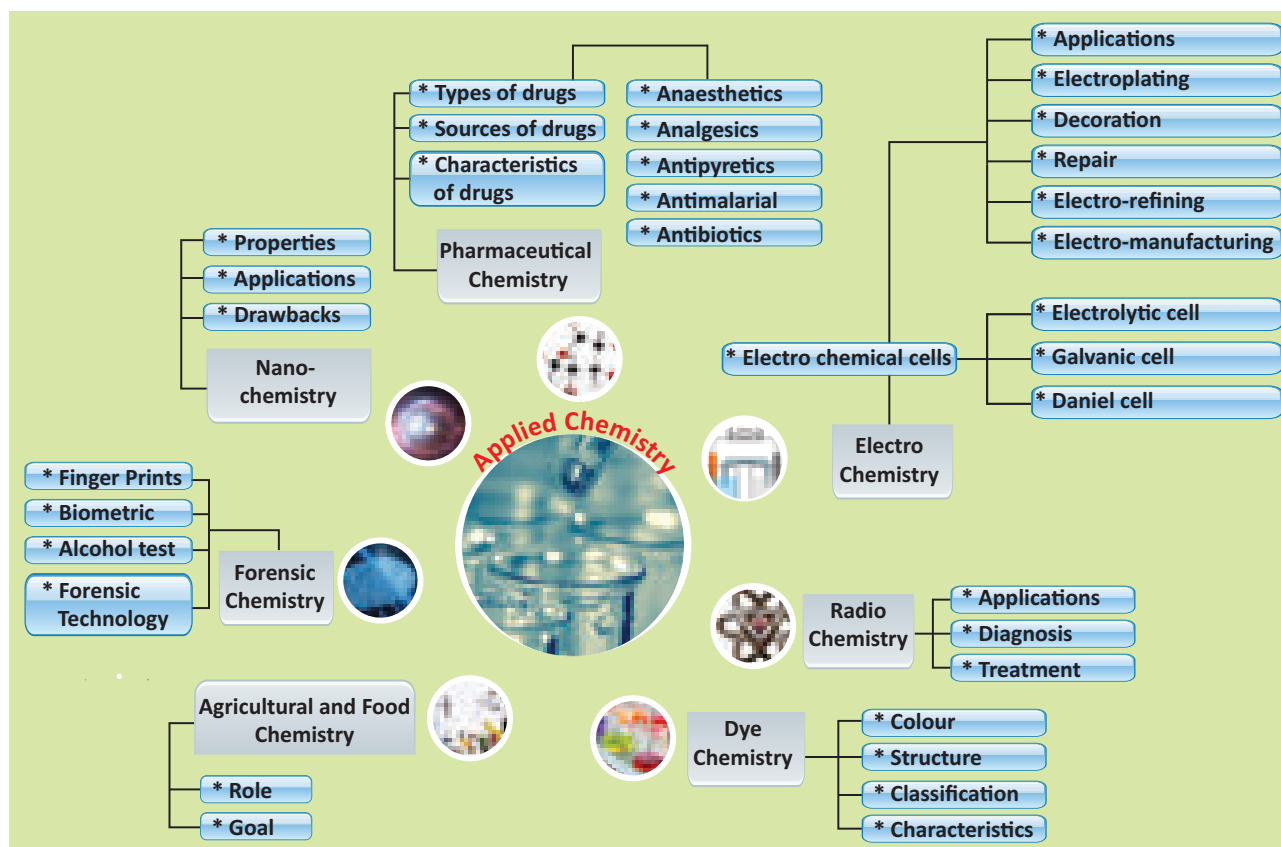

## ICT CORNER

## Applied Chemistry

Experiment with radioactive elements to know about its half-life

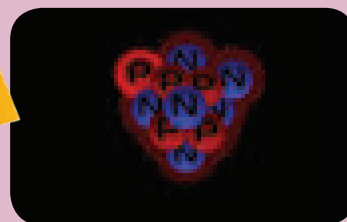

### Steps

- Use the given URL to open the simulation page and allow the “javascript” to play, if asks. Read the given description on how to perform the half-life simulation.
- Click the “Years Passed” button to increase the years by 1000 and press “Count the Remaining Atom” to know how much of the atoms have become “Daughter atoms”.
- Use the “Table/Graph” button situated below the description to record your observations.
- Press the “video” button to view the process of degradation of radioactive atoms and its calculation

### Radioactive Atoms Half-Life

URL: [http://www.glencoe.com/sites/common\\_assets/science/virtual\\_labs/E18/E18.html](http://www.glencoe.com/sites/common_assets/science/virtual_labs/E18/E18.html)

\*Pictures are indicative only



B567\_9\_SCI\_EM\_T3

## ANIMAL KINGDOM

 Learning Objectives

After completing this lesson, students will be able to:

- understand the classification of animal kingdom.
- identify and study the different groups of animals.
- list out the general characteristics of animals based on grades of organization, types of symmetry, coelom and various body activity.
- recognize that binomial classification has Latin and Greek words.
- identify the first name as genus and second name as species.
- recall the salient features of each phylum.

**Introduction**

The variety of living organisms surrounding us is incomprehensible. Nearly 1.5 million species of organism which have been described are different from one another. The uniqueness is due to the diversity in the life forms whether it is microbes, plants or animals. Every organism exhibits variation in their external appearance, internal structure and behavior, mode of living etc. This versatile nature among the living animals forms the basis of diversity. The diversity among the living organisms can be studied in an effective way by arranging animals in an orderly and systematic manner. The study of various organisms would be difficult without a suitable method of classification.

The method of arranging organism into groups on the basis of similarities and differences is called **classification**. Taxonomy is the science of classification which makes the study of wide variety of organisms easier. It helps us to

understand the relationship among different group of animals. The first systematic approach to the classification of living organisms was made by a Swedish botanist, Carolus Linnaeus. He generated the standard system for naming organisms in terms of genus, species and more extensive groupings using Latin terms.

**17.1 Classification of Living Organisms**

Classification is the ordering of organism into groups on the basis of their similarities, dissimilarities and relationships. The five kingdom classification are Monera, Protista, Fungi, Plantae and Animalia. These groups are formed based on cell structure, mode of nutrition, body organization and reproduction. On the basis of hierarchy of classification, the organisms are separated into smaller and smaller groups which form the basic unit of classification.



**Species:** It is the lowest taxonomic category. For example, the large Indian parakeet (*Psittacula eupatra*) and the green parrot (*Psittacula krameri*) are two different species of birds. They belong to different species *eupatra* and *krameri* and cannot interbreed.

**Genus:** It is a group of closely related species which constitute the next higher category called genus. For example, the Indian wolf (*Canis pallipes*) and the Indian jackal (*Canis aureus*) are placed in the same genus *Canis*.

**Family:** A group of genera with several common characters form a family. For example, leopard, tiger and cat share some common characteristics and belong to the larger cat family *Felidae*.

**Order:** A number of related families having common characters are placed in an order. Monkeys, baboons, apes and Man although belong to different families, are placed in the same order Primates. Since all these animals possess some common features, they are placed in the same order.

**Class:** Related or similar orders together form a class. The orders of different animals like those of rabbit, rat, bats, whales, chimpanzee and human share some common features such as the presence of skin and mammary glands. Hence, they are placed in class Mammalia.

**Phylum:** Classes which are related with one another constitute a phylum. The classes of different animals like mammals, birds, reptiles, frogs and fishes constitute Phylum Chordata which have a notochord or back bone.

**Kingdom:** It is the highest category and the largest division to which microorganisms, plants and animals belong to. Each kingdom is fundamentally different from one another, but has the same fundamental characteristics in all organisms grouped under that Kingdom.

The taxa of living organisms are in a hierarchy of categories as follows.

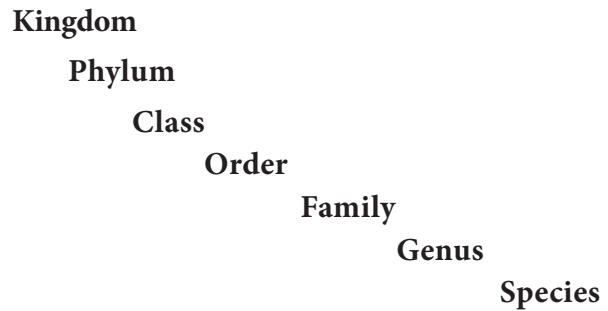

### 17.1.1 Basis for Classification

We can divide the Animal kingdom based on the level of organization (arrangement of cells), body symmetry, germ layers and nature of coelom.

**Level of organization:** Animals are grouped as unicellular or multicellular based on cell, tissue, organ and organ system level of organization

**Symmetry:** It is a plane of arrangement of body parts. Radial symmetry and bilateral symmetry are the two types of symmetry. In radial symmetry the body parts are arranged around the central axis. If the animal is cut through the central axis in any direction, it can be divided into similar halves. e.g. Hydra, jelly fish and star fish. In bilateral symmetry, the body parts are arranged along a central axis. If the animal is cut through the central axis, we get two identical halves e.g. Frog.

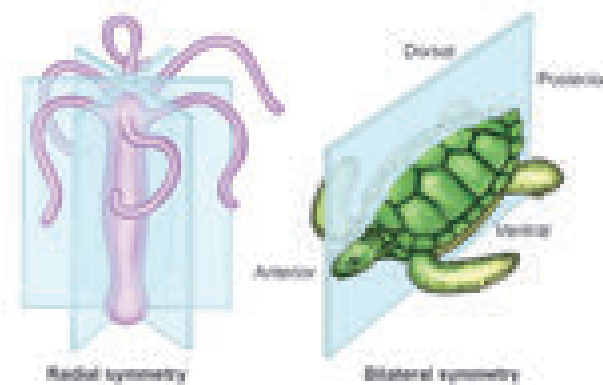

Figure 17.1 Radial and Bilateral Symmetry

**Germ layers:** Germ layers are formed during the development of an embryo. These layers give rise to different organs, as the embryo becomes an adult.

Organisms with two germ layers, the ectoderm and the endoderm are called



## Classification of kingdom Animalia based on fundamental features

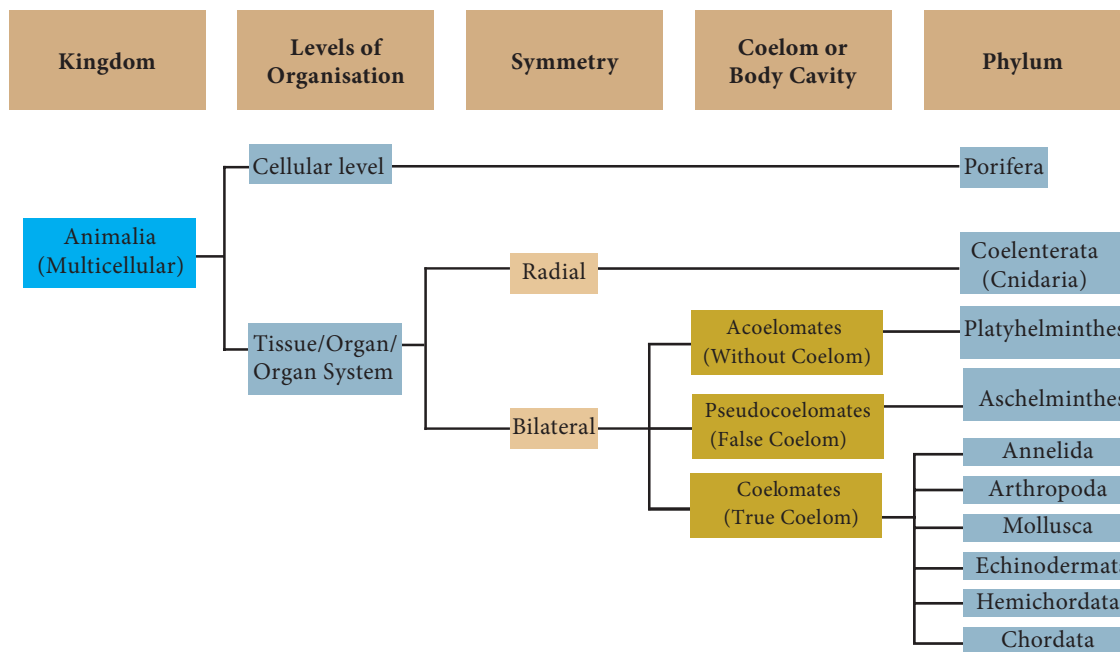

**diploblastic** animals. e.g Hydra. Organisms with three germ layers, ectoderm, mesoderm and endoderm are called **triploblastic** animals. e.g Rabbit

**Coelom:** It is a fluid-filled body cavity. It separates the digestive tract from the body wall. A true body cavity or coelom is one that is located within the mesoderm. Based on the nature of the coelom, animals are divided into 3 groups.

1. Acoelomates do not have a body cavity e.g Tapeworm.
2. Pseudocoelomates have a false body cavity e.g Roundworm.
3. Coelomates or Eucoelomates have a true coelom e.g Earthworm, Frog.

Animal Kingdom is further divided into two groups based on the presence or absence of notochord as below.

1. Invertebrata
2. Chordata-Prochordata and Vertebrata

Animals which do not possess notochord are called as **Invertebrates** or **Non- chordates**. Animals which possess notochord or backbone are called as **Chordates**. You have already studied the characters of single celled protozoans.

### More to Know

**Notochord** is a rod like structure formed on the mid-dorsal side of the body during embryonic development. Except primitive forms in which the notochord persists throughout life in all other animals it is replaced by a backbone.

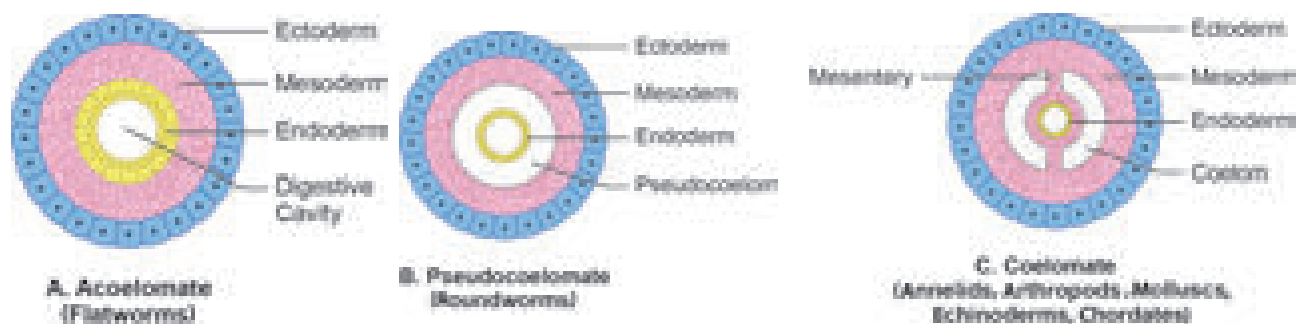

Figure 17.2 Types of Coelom

### 17.1.2 Binomial Nomenclature

Carolus Linnaeus introduced the method of naming the animals with two names known as binomial nomenclature. The first name is called **genus** and the first letter of genus is denoted in capital and the second one is the **species** name denoted in small letter. The binomial names of some common animals are as follows.

Common name	Binomial name
Amoeba	<i>Amoeba proteus</i>
Hydra	<i>Hydra vulgaris</i>
Tapeworm	<i>Taenia solium</i>
Roundworm	<i>Ascaris lumbricoides</i>
Earthworm	<i>Lampito mauritii</i> / <i>Perionyx excavatus</i>
Leech	<i>Hirudinaria granulosa</i>
Cockroach	<i>Periplaneta americana</i>
Snail	<i>Pila globosa</i>
Star fish	<i>Asterias rubens</i>
Frog	<i>Rana hexadactyla</i>
Wall lizard	<i>Podarcis muralis</i>
Crow	<i>Corvus splendens</i>
Peacock	<i>Pavo cristatus</i>
Dog	<i>Canis familiaris</i>
Cat	<i>Felis felis</i>
Tiger	<i>Panthera tigris</i>
Man	<i>Homo sapiens</i>

## 17.2 Invertebrata

### 17.2.1 Phylum Porifera (Pore bearers)

These are multicellular, non-motile aquatic organisms, commonly called as sponges. They exhibit **cellular grade of organization**. Body is perforated with many pores called **ostia**. Water enters into the body through ostia and leads to a **canal system**. It circulates water throughout the body and carries food, oxygen. The body wall contains **spicules**, which form the skeletal framework. Reproduction is by both asexual and sexual methods. e.g- *Euplectella*, *Sycon*.



Euplectella



Sycon

Figure 17.3 Pore bearers

### 17.2.2 Phylum Coelenterata (Cnidaria)

Coelenterates are aquatic organisms, mostly marine and few fresh water forms. They are multicellular, radially symmetrical animals, with **tissue grade of organization**. Body wall is **diploblastic** with two layers. An outer ectoderm and inner endoderm are separated by non-cellular jelly like substance called **mesoglea**. It has a central gastrovascular cavity called **coelenteron** with mouth surrounded by short **tentacles**. The tentacles bear stinging cells called **cnidoblast** or **nematocyst**.



Figure 17.4 Jelly fish

Many coelenterates exhibit **polymorphism**, which is the variation in the structure and function of the individuals of the same species. They reproduce both asexually and sexually. e.g. Hydra, Jellyfish.

### 17.2.3 Phylum Platyhelminthes (Flat worms)

They are bilaterally symmetrical, triploblastic, **acoelomate** (without body cavity) animals. Most of them are **parasitic** in nature. **Suckers** and **hooks** help the animal to attach itself to the body of the host. Excretion occurs by specialized cells called **flame cells**. These worms are **hermaphrodites** having



Liver fluke



Tape worm

Figure 17.5 Flat worms

both male and female reproductive organs in a single individual. e.g- Liverfluke, Tapeworm.

### 17.2.4 Phylum Aschelminthes (Round worms)

Aschelminthes are bilaterally symmetrical, triploblastic animals. The body cavity is a **pseudocoelom**. They exist as **free-living soil forms** or as **parasites**. The body is round and pointed at both the ends. It is unsegmented and covered by **thin cuticle**. Sexes are separate. The most common diseases caused by nematodes in human beings are **elephantiasis** and **ascariasis**. e.g- *Ascaris*, *Wuchereria*.



Male

Female

Figure 17.6 Round worms

### 17.2.5 Phylum Annelida (Segmented worms)

These are bilaterally symmetrical, triploblastic, **first true coelomate animals** with **organ-system grade of organization**. Body is externally divided into segments called **metameres** joined by ring like structures called **annuli**. It is covered by moist thin cuticle. **Setae** and **parapodia** are locomotor organs. Sexes may be separate or united (hermaphrodites). e.g- *Nereis*, *Earthworm*, *Leech*.

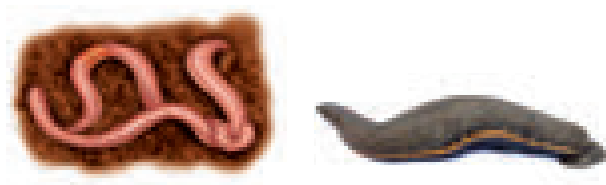

Earthworm

Leech

Figure 17.7 Segmented worms

### 17.2.6 Phylum Arthropoda (Animals with jointed legs)

Arthropoda is the largest phylum of the animal kingdom. They are bilaterally

symmetrical, triploblastic and coelomate animals. The body is divisible into head, thorax and abdomen. Each thoracic segment bears paired **jointed legs**. Exoskeleton is made of **chitin** and is shed periodically as the animal grows. The casting off and regrowing of exoskeleton is called **moulting**.

Body cavity is filled with **haemolymph** (blood). The blood does not flow in blood vessels and circulates throughout the body (open circulatory system). Respiration is through body surface, **gills** or **tracheae** (air tubes). Excretion occurs by **malpighian tubules** or **green glands**. Sexes are separate. E.g., Prawn, Crab, Cockroach, Millipede, Centipedes, Spider, Scorpion.



Centipede

Millipede

Figure 17.8 Animals with jointed legs

**DO YOU KNOW?** Centipede means 'hundred legs'. But most species have only 30 pairs. Millipedes have two pairs of legs on each segment. This name means 'thousand legs'. But, most millipedes have only about a hundred.

#### Activity 1

Identify the following pictures of Arthropods.

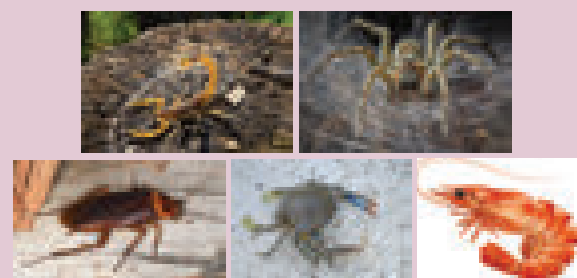

### 17.2.7 Phylum Mollusca (Soft Bodied Animals)

They are diversified group of animals living in marine, fresh water and terrestrial habitats. Body is bilaterally symmetrical, soft and without segmentation. It is divided into **head, muscular foot** and **visceral mass**. The foot helps in locomotion. The entire body is covered with fold of thin skin called **mantle**, which secretes outer hard **calcareous shell**. Respiration is through gills (**ctenidia**) or lungs or both. Sexes are separate with larval stages during development. e.g- Garden snail, Octopus.

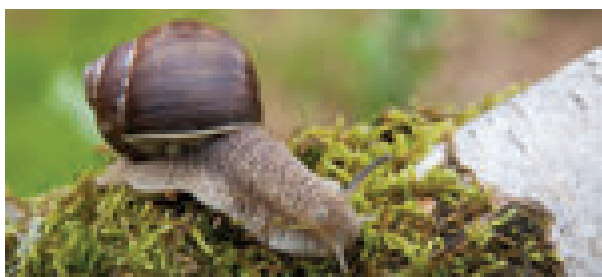

Figure 17.9 Garden Snail



Octopus is the only invertebrate that is capable of emotion, empathy, cognitive function, self awareness, personality and even relationships with humans. Some speculate that without humans, octopus would eventually take our place as the dominate life form on earth.



### 17.2.8 Phylum Echinodermata (Spiny Skinned Animals)

They are exclusively free-living marine animals. These are triploblastic and true coelomates with organ-system grade of organization. **Adult animals** are **radially symmetrical** but **larvae** remain **bilaterally symmetrical**. A unique feature is the presence of fluid filled **water vascular system**. Locomotion occurs by **tube feet**. Body wall is covered with spiny hard **calcareous ossicles**. e.g- Star fish, Sea urchin.



Star Fish

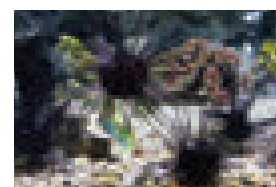

Sea Urchin

Figure 17.10 Spiny Skinned Animals

### 17.2.9 Phylum Hemichordata

Hemichordates are marine organisms with soft, vermiform and unsegmented body. They are bilaterally symmetrical, coelomate animals with **non-chordate** and **chordate features**. They have gill slits but **do not have notochord**. They are **ciliary feeders** and mostly remain as **tubicolous forms**. E.g- *Balanoglossus* (Acorn worms).

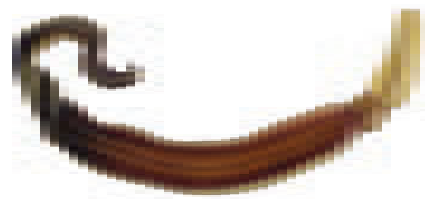

Figure 17.11 Balanoglossus

## 17.3 Chordata

Chordates are characterized by the **presence of notochord, dorsal nerve cord** and **paired gill pouches**. **Notochord** is a long rod like support along the back of the animal separating the gut and nervous tissue. All chordates are triploblastic and coelomate animals. **Phylum Chordata** is divided into two groups: **Prochordata** and **Vertebrata**.

### 17.3.1 Prochordata

The prochordates are considered as the forerunners of vertebrates. Based on the nature of the notochord, prochordata is classified into subphylum Urochordata and subphylum Cephalochordata.

#### Subphylum Urochordata

**Notochord** is present only in the **tail region** of free-living larva. Adults are sessile forms and mostly degenerate. The body is covered with a **tunic** or **test**. e.g. *Ascidian*





Figure 17.12 Ascidian

### Subphylum Cephalochordata

Cephalochordates are small fish like marine chordates with unpaired dorsal fins. The notochord extends throughout the entire length of the body. E.g. *Amphioxus*

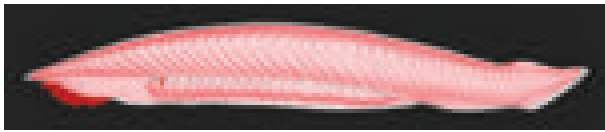

Figure 17.13 Amphioxus

### 17.3.2 Vertebrata

This group is characterized by the presence of vertebral column or backbone. Notochord in an embryonic stage gets replaced by the vertebral column, which forms the chief skeletal axis of the body. Vertebrata are grouped into six classes.

#### Class: Cyclostomata

Cyclostomes are jawless vertebrates (mouth not bounded by jaws). Body is elongated and eel like. They have circular mouth. Skin is slimy and scaleless. They are ectoparasites of fishes. E.g. *Hagfish*.



Figure 17.14 Lamprey

#### Class: Pisces

Fishes are poikilothermic (**cold-blooded**), aquatic vertebrates with jaws. The **streamlined**

**body** is divisible into head, trunk and tail. Locomotion is by **paired** and **median fins**. Their body is covered with **scales**. Respiration is through **gills**. The heart is two chambered with an auricle and a ventricle. There are two main types of fishes.

- (i) **Cartilaginous fishes**, with skeleton made of cartilages e.g. Sharks, Skates.
- (ii) **Bony fishes** with skeleton made of bones e.g. Carps, Mulletts.

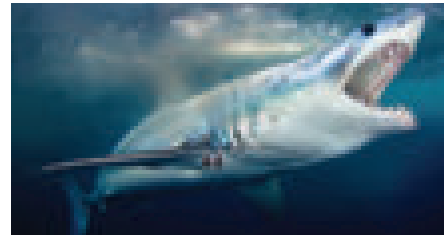
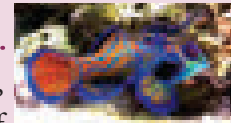

Figure 17.15 Shark

#### More to Know

The smallest vertebrate, Philippine goby/dwarf pygmy goby is a tropical species fish found in brackish water and mangrove areas in south East Asia, measuring only 10 mm in length.



#### Class: Amphibia (amphi- both; bios- life)

These are the first four legged (**tetrapods**) vertebrates with **dual adaptation** to live in both land and water. The body is divisible into head and trunk. Their skin is moist and have **mucus glands**. Respiration is through **gills, lungs, skin** or **buccopharynx**. The heart is three chambered with two auricles and one ventricle. Eggs are laid in water. The **tadpole larva**, transforms into an adult. e.g-Frog, Toad.



The Chinese giant salamander



*Andrias davidians* is the largest amphibian in the world. Its length is about five feet and eleven inches. It weighs about 65 kg, found in Central and South China.

## Class: Reptilia (repere- to crawl or creep)

These vertebrates are fully adapted to live on land. Their body is covered with **horny epidermal scales**. Respiration is through **lungs**. The heart is three chambered with an exemption of crocodiles, which have four-chambered heart. Most of the reptiles lay their eggs with tough outer shell e.g Calotes, Lizard, Snake, Tortoise, Turtle.



Figure 17.16 Calotes



Figure 17.17 Pigeon

### More to Know

**State bird of Tamil Nadu**  
Common Emerald dove.  
(*Chalcophaps indica*)

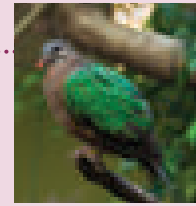

## Class: Aves (avis – bird)

Birds are **homeothermic (warm-blooded)** animals with several adaptations to fly. The **spindle or boat shaped body** is divisible into head, neck, trunk and tail. The body is covered with **feathers**. **Forelimbs** are modified into **wings** for flight. Hindlimbs are adapted for walking, perching or swimming. The respiration is through lungs, which have **air sacs**. Bones are filled with air (**pneumatic bones**), which reduces the body weight. They lay large yolk laden eggs. They are covered by hard **calcareous shell**. e.g. Parrot, Crow, Eagle, Pigeon, Ostrich .

## Class: Mammalia (mamma-breast)

Mammals are **warm-blooded animals**. The skin is covered with **hairs**. It also bears **sweat** and **sebaceous** (oil) glands. The body is divisible into head, neck, trunk and tail. Females have **mammary glands**, which secrete milk for feeding the young ones. The **external ears** or **pinnae** is present. Heart is four chambered and they breathe through lungs. Except egg laying mammals (Platypus, and Spiny anteater), all other mammals give birth to their young ones (**viviparous**). Placenta is the unique characteristic feature of mammals.e.g Rat, Rabbit, Man.

### Classification of Phylum Chordata

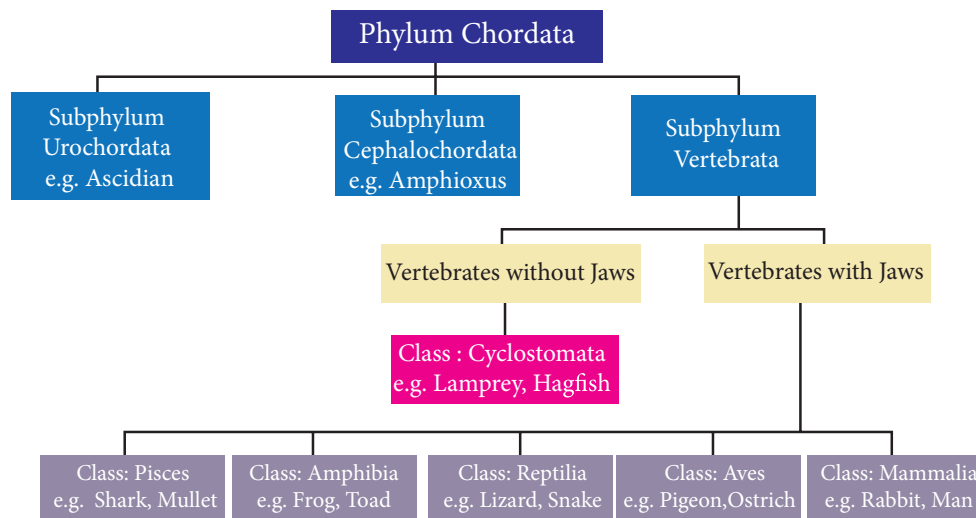



**Figure 17.18** Rabbit

### More to Know



The gigantic **Blue whale** which is 35 meters long and 120 tons in weight is the biggest vertebrate animal.

### Points to Remember

- ❖ Classification is the ordering of organism into groups on the basis of their similarities, dissimilarities and relationships.
- ❖ Animals are grouped as unicellular or multicellular based on cell, tissue, organ and organ system level of organization.
- ❖ In radial symmetry the body parts are arranged around the central axis.
- ❖ In bilateral symmetry, the body parts are arranged along a central axis.
- ❖ Coelom is a fluid-filled body cavity. It separates the digestive tract from the body wall.
- ❖ Animals which do not possess notochord structure are called as Invertebrates or Non- chordates.
- ❖ Animals which possess notochord or backbone are called as Chordates.
- ❖ The prochordates are considered as the forerunner of vertebrates.

## A-Z GLOSSARY

<b>Acoelomates</b>	Animals which do not have a body cavity.
<b>Amphibian</b>	Cold-blooded vertebrate animal of a class that comprises the frogs, toads, newts, salamanders.
<b>Annelida</b>	Phylum that comprises the segmented worms which include earthworms and leeches.
<b>Aves</b>	Vertebrates which comprises the birds.
<b>Coelomates</b>	Animals which have a true coelom e.g Earthworm, Frog.
<b>Classification</b>	Arrangement of groups of animals, the members of which have one or more characteristics in common.
<b>Mammals</b>	Warm-blooded vertebrate animals that possess hairs, mammary glands and feed their young ones.
<b>Pseudocoleomates</b>	False body cavity which is not bounded by true epithelial lining. e.g Roundworm
<b>Toads</b>	Anurans with smooth skin than that of frogs, terrestrial and leap rather than jump.



## TEXTBOOK EXERCISES



### I. Choose the correct answer.

- Find the group having only marine members.  
(a) Mollusca (b) Coelenterata  
(c) Echinodermata (d) Porifera
- Mesoglea is present in  
(a) Porifera (b) Coelenterata  
(c) Annelida (d) Arthropoda
- Which one of the following pairs is not a poikilothermic animal?  
(a) Fishes and Amphibians  
(b) Amphibians and Aves  
(c) Aves and Mammals  
(d) Reptiles and Mammals
- Identify the animal having four chambered heart.  
(a) Lizard (b) Snake  
(c) Crocodile (d) Calotes
- The animal without skull is  
(a) Acrania (b) Acephalia  
(c) Apteria (d) Acoelomate
- Hermaphrodite organisms are  
(a) Hydra, Tape worm, Earthworm, Amphioxus  
(b) Hydra, Tape worm, Earthworm, Ascidian  
(c) Hydra, Tape worm, Earthworm, Balanoglossus  
(d) Hydra, Tape worm, Ascaris, Earthworm
- Poikilothermic organisms are  
(a) Fish, Frog, Lizard, Man  
(b) Fish, Frog, Lizard, Cow  
(c) Fish, Frog, Lizard, Snake  
(d) Fish, Frog, Lizard, Crow

- Air sacs and Pneumatic bones are seen in  
(a) fish (b) frog  
(c) bird (d) bat
- Excretory organ of tape worm is  
(a) flame cells (b) nephridia  
(c) body surface (d) solenocytes
- Water vascular system is found in  
(a) Hydra (b) Earthworm  
(c) Star fish (d) Ascaris

### II. Fill in the blanks.

- The skeletal framework of Porifera is \_\_\_\_\_.
- Ctenidia are respiratory organs in \_\_\_\_\_.
- Skates are \_\_\_\_\_ fishes.
- The larvae of an amphibian is \_\_\_\_\_.
- \_\_\_\_\_ are jawless vertebrates.
- \_\_\_\_\_ is the unique characteristic feature of mammal.
- Spiny anteater is an example for \_\_\_\_\_ mammal.

### III. State whether true or false. If false, correct the statement.

- Canal system is seen in coelenterates.
- Hermaphrodite animals have both male and female sex organs.
- Trachea are the respiratory organ of Annelida.
- Bipinnaria is the larva of Mollusca.
- Balanoglossus is a ciliary feeder.
- Fishes have two chambered heart.
- Skin of reptilians are smooth and moist.

- Wings of birds are the modified forelimbs.
- Female mammals have mammary glands.

#### IV. Match the following.

PHYLUM	EXAMPLES
(A) Coelenterata	(i) Snail
(B) Platyhelminthes	(ii) Starfish
(C) Echinodermata	(iii) Tapeworm
(D) Mollusca	(iv) Hydra

#### V. Answer very briefly.

- Define taxonomy.
- What is nematocyst?
- Why coelenterates are called diploblastic animals?
- List the respiratory organs of amphibians.
- How does locomotion take place in starfish?
- Are jellyfish and starfish similar to fishes? If no justify the answer.
- Why are frogs said to be amphibians?

#### VI. Answer briefly.

- Give an account on phylum Annelida.
- Differentiate between flat worms and round worms?
- Outline the flow charts of Phylum Chordata.
- List five characteristic features of fishes.
- Comment on the aquatic and terrestrial habits of amphibians.
- How are the limbs of the birds adapted for avian life?

#### VII. Answer in detail.

- Describe the characteristic features of different Prochordates.
- Give an account on phylum Arthropoda.



### REFERENCE BOOKS

- Manual of Zoology Vol. I. Part I. (Invertebrata), M. Ekambaranatha Ayyar and T.N. Ananthakrishnan, Reprint 2003. S. Viswanathan (Printers and Publishers) Pvt. Ltd Chennai.
- Manual of Zoology Vol. I. Part. II. (Invertebrata), M. Ekambaranatha Ayyar and T.N. Ananthakrishnan, Reprint 2003. S. Viswanathan (Printers and Publishers) Pvt. Ltd Chennai.
- Manual of Zoology Vol. II. Chordata M. Ekambaranatha Ayyar and T.N. Ananthakrishnan, Reprint 2003. S. Viswanathan (Printers and Publishers) Pvt. Ltd Chennai.
- Chordate Zoology E. L. Jordan and P. S. Verma. Reprint 2003. S. Chand .and Company, New Delhi.



### INTERNET RESOURCES

- <http://home.pcisys.net/~dlblanc/taxonomy.html>
- [http://can-do.com/uci/lessons 98/Invertebrates.html](http://can-do.com/uci/lessons%2098/Invertebrates.html)
- <http://www.student.loretto.org/zoology/chordates.html>

### Concept Map

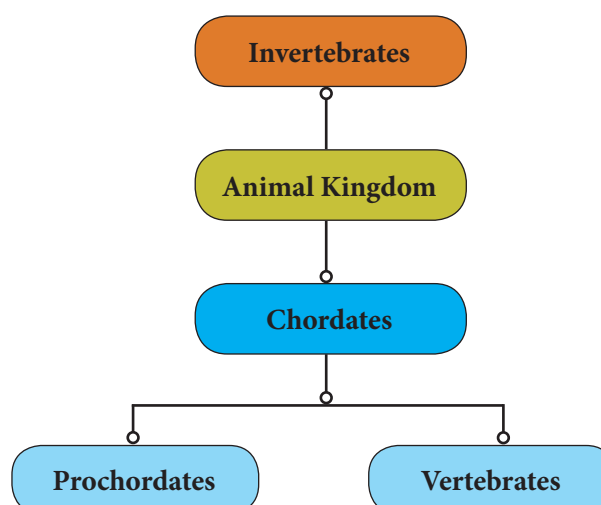

# Organization of Tissues

## Learning Objectives

After completing this lesson, students will be able:

- know the different types of tissues and their morphology.
- identify how tissues are organized in specific patterns to form organs.
- understand how tissues perform life activities in plants and animals.
- gain knowledge about the structural organisation of tissues.
- get familiarized with the process, types and significance of cell division.



## Introduction

Unicellular organisms like bacteria and protozoans are made of single cells. On the other hand, multicellular organisms, like higher plants and animals, are composed of millions of different types of cells that are grouped into different levels of organization. Multicellular organisms have specialized cells, tissues, organs and organ systems that perform specific functions.

Group of cells positioned and designed to perform a particular function is called a tissue. An organ is a structure made up of a collection of tissues that carry out specialized functions. For example, in plants the root, stem and leaves are organs, whereas xylem and phloem are tissues. Similarly in animals stomach, for example, is an organ that consists of tissues made of epithelial cells, gland cells and muscle cells. In this chapter, you will learn about different types of plant and animal tissues and how they are modified to coordinate life activities.

## 18.1 Plant Tissues

Plants are made up of vegetative and reproductive tissues. In general, plant tissues are classified into two types namely:

- i. Meristems or Meristematic tissues.
- ii. Permanent tissues

### 18.1.1 Meristematic Tissues (Meristems)

The term 'meristem' is derived from the greek word 'Meristos' which means divisible or having cell division activity. Meristematic tissues are group of immature cells that are capable of undergoing cell division. In plants, meristem is found in zones where growth can take place. Example: apex of stem, root, leaf primordia, vascular cambium, cork cambium, etc.,

#### Characteristic features:

- a) They are living cells.
- b) Cells are small, oval, polygonal or round in shape.
- c) They are thin walled with dense cytoplasm, large nuclei and small vacuoles.

- d) They undergo mitotic cell division.
- e) They do not store food materials.

### A. Types of Meristems based on position

On the basis of their position in the plant, meristems are of three types: Apical meristem, Intercalary meristem and Lateral meristem.

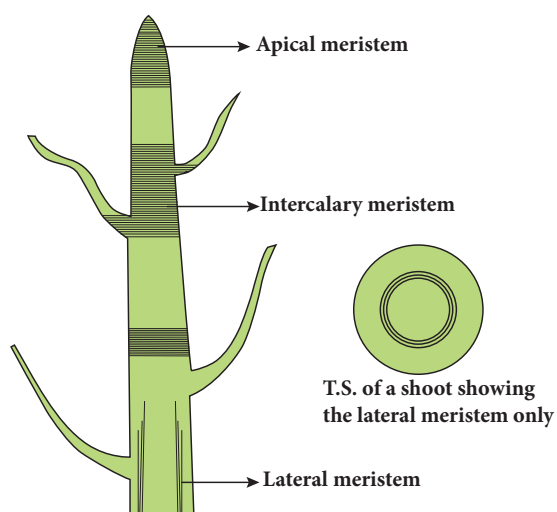

**Figure 18.1** Longitudinal section of shoot apex showing location of meristems and young leaves.

**Apical meristem:** These are found at the apices or growing points of root and shoot and bring about increase in length.

**Intercalary meristem:** It lies between the region of permanent tissues and is part of primary meristem. It is found either at the base of leaf (e.g. pinus) or at the base of internodes (e.g. grasses).

**Lateral Meristem:** These are arranged parallel and causes the thickness of the plant part.

### B. Functions

Meristems are actively dividing tissues of the plant, that are responsible for primary (elongation) and secondary (thickness) growth of the plant.

#### 18.1.2 Permanent Tissues

Permanent tissues are those in which, growth has stopped either completely or for the time being. At times, they become meristematic partially or wholly. Permanent tissues are of two types, namely: simple tissue and complex tissue.

### A. Simple Tissues

Simple tissues are homogeneous tissues composed of structurally and functionally similar cells. eg., Parenchyma, Collenchyma and Sclerenchyma.

**Parenchyma:** Parenchyma are simple permanent tissues composed of living cells. Parenchyma cells are thin walled, oval, rounded or polygonal in shape with well developed spaces among them. In aquatic plants, parenchyma possesses intercellular air spaces, and is named as Aerenchyma. When exposed to light, parenchyma cells may develop chloroplasts and are known as Chlorenchyma.

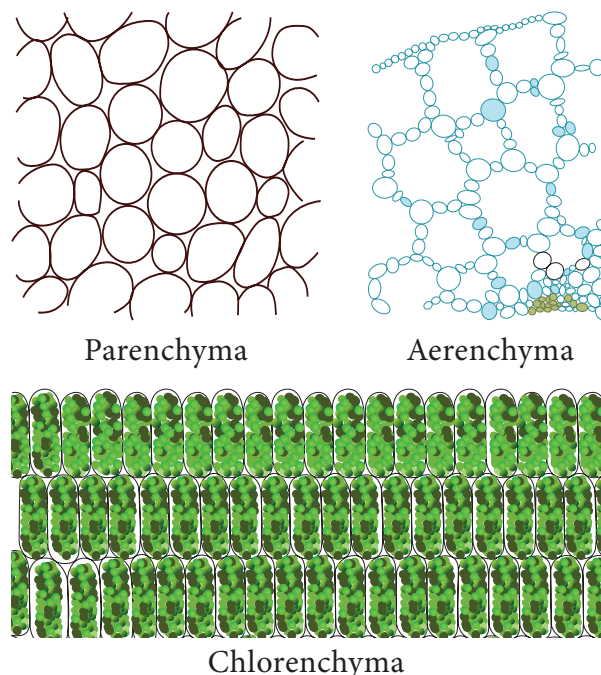

**Figure 18.2** Types of Parenchyma

Parenchyma may store water in many succulent and xerophytic plants. It also serves the functions of storage of food reserves, absorption, buoyancy, secretion etc.,

**DO YOU KNOW?** In potato, parenchyma vacuoles are filled with starch. In apple, parenchyma stores sugar

**Collenchyma:** Collenchyma is a living tissue found beneath the epidermis. Cells are elongated with unevenly thickened walls.

Cells have rectangular oblique or tapering ends and persistent protoplast. They possess thick primary non-lignified walls. They provide mechanical support for growing organs.

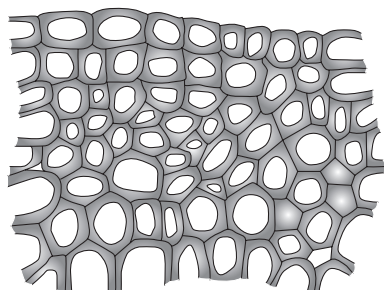

**Figure 18.3** Collenchyma

**Sclerenchyma:** Sclerenchyma consists of thick walled cells which are often lignified. Sclerenchyma cells are dead and do not possess living protoplasts at maturity. Sclerenchyma cells are grouped into fibres and sclereids.

Fibres are elongated sclerenchymatous cells, usually with pointed ends. Their walls are lignified. Fibres are abundantly found in many plants. The average length of fibres is 1 to 3 mm, however in plants like *Linum usitatissimum* (flax), *Cannabis sativa* (hemp) and *Corchorus capsularis* (jute), fibres are extensively longer, ranging from 20 mm to 550 mm.

Sclereids are widely distributed in plant body. They are usually broad, may occur in single or in groups. Sclereids are isodiametric, with lignified walls. Pits are prominent and seen along the walls.

Lumen is filled with wall materials. Sclereids are also common in fruits and seeds.

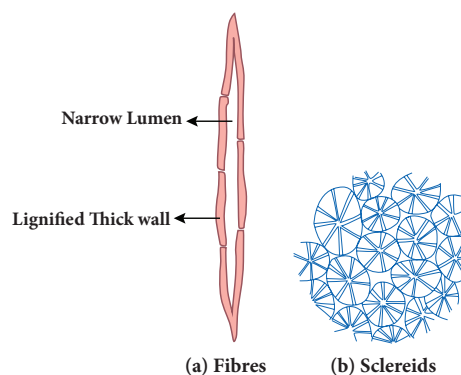

**Figure 18.4** Sclerenchyma (a) Fibres, (b) Sclereids

## B. Complex tissues

Complex tissues are made of more than one type of cells that work together as a unit. Complex tissues consist of parenchyma and sclerenchyma cells. However, collenchymatous cells are not present in such tissues. Common examples are xylem and phloem.

### i. Xylem

Xylem is a conducting tissue which conducts water, mineral nutrients upward from root to leaves. Xylem gives mechanical support to the plant body. Xylem is composed of: (i) xylem tracheids (ii) xylem fibres (iii) xylem vessels and (iv) xylem parenchyma.

**Xylem tracheids:** These are elongated or tube-like dead cells with hard, thick and

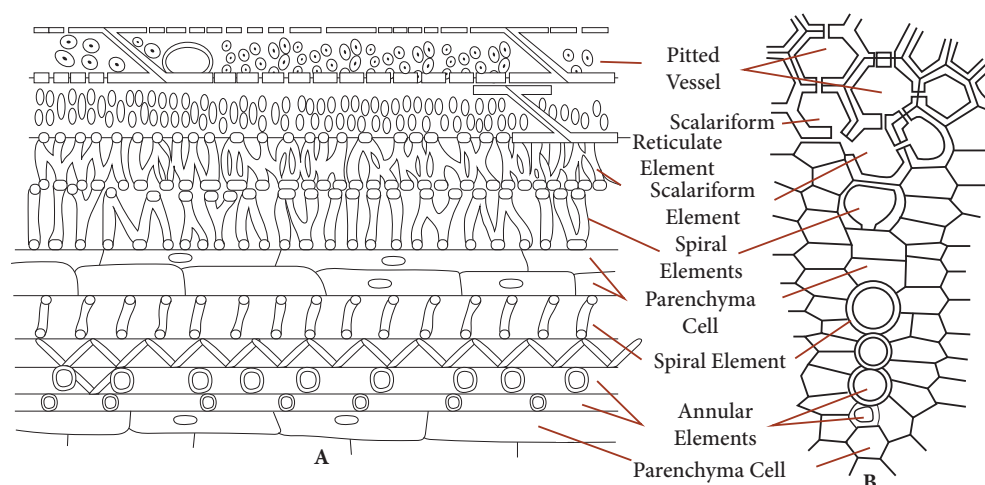

**Figure 18.5** A. xylem longitudinal section B. xylem transverse section



lignified walls. Their ends are tapering, blunt or chisel-like and devoid of protoplast. They have large lumen without any content. Their function is conduction of water and providing mechanical support to the plant.

**Xylem fibres:** These cells are elongated, lignified and pointed at both the ends. Xylem fibres provide mechanical support to the plant.

**Xylem vessels:** These are long cylindrical, tube like structures with lignified walls and wide central lumen. These cells are dead as these do not have protoplast. They are arranged in longitudinal series in which the partitioned walls (transverse walls) are perforated, and so the entire structure looks-like a water pipe. Their main function is to transport of water and also to provide mechanical strength.

**Xylem parenchyma:** These are living and thin walled cells. The main function of xylem parenchyma is to store starch and fatty substances.

## ii. Phloem

Phloem is a complex tissue and consists of the following elements: Sieve elements, Companion cells, Phloem fibres, and Phloem parenchyma.

**Sieve elements:** The conducting elements of phloem are collectively called as Sieve elements. Sieve tubes are elongated, tube-like slender cells placed end to end. The transverse walls at the ends are perforated and are known as sieve plates. The main function of sieve tubes is translocation of food, from leaves to the storage organs of the plants.

**Companion cells:** These are elongated cells attached to the lateral wall of the sieve tubes. A companion cell may be equal in length to the accompanying sieve tube element or the mother cell may be divided transversely forming a series of companion cells.

**Phloem parenchyma:** The phloem parenchyma are living cells which have cytoplasm and nucleus. Their function is to store food materials.

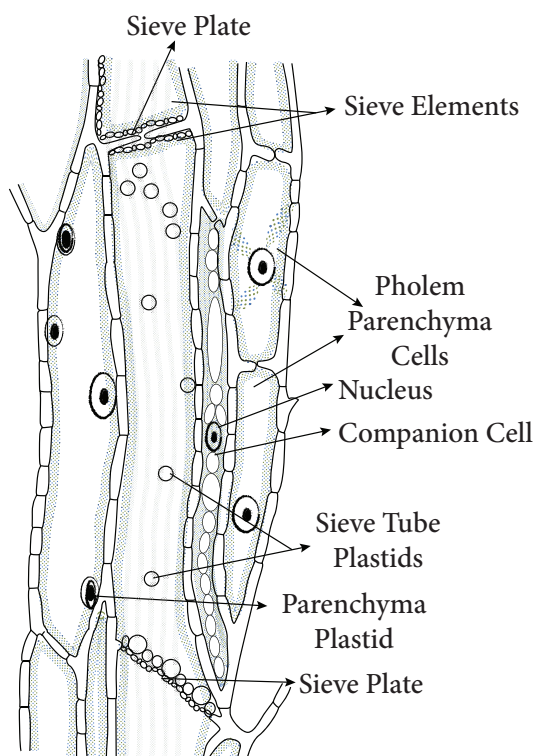

**Figure 18.6** Longitudinal section of Phloem tissue

**Table 18.1** Differences between Xylem and Phloem.

Xylem	Phloem
Conducts water and minerals.	Conducts organic solutes or food materials.
Conduction is mostly unidirectional i.e., from roots to apical parts of the plant.	Conduction may be bidirectional from leaves to storage organs and growing parts or from storage organs to growing parts of plants.
Conducting channels are tracheids and vessels.	Conducting channels are sieve tubes.
Component of xylem include tracheid vessels, xylem parenchyma and xylem fibres.	Components are sieve elements, companion cells, phloem parenchyma and phloem fibres.

**Phloem fibers:** Sclerenchymatous cells associated with primary and secondary phloem are commonly called phloem fibers. These cells are elongated, lignified and provide mechanical strength to the plant body.

**Table 18.2** Differences between Meristematic tissue and Permanent tissue.

Meristematic tissue	Permanent tissue
Cell wall is thin and elastic.	Cell wall is thick.
Component cells are small, spherical or polygonal and undifferentiated.	Component cells are large, differentiated with different shapes.
Cytoplasm is dense, and vacuoles are nearly absent.	Usually large central vacuole is present in living permanent cells.
Intercellular spaces absent.	Intercellular spaces present.
Nucleus is large and prominent.	Nucleus is less conspicuous.
Cells grow and divide regularly.	Cells do not normally divide.
Provides mechanical support and elasticity to the plant body.	Provides only mechanical support.

## 18.2 Animal Tissues

An assemblage of one or more types of specialized cells held together with extracellular material constitute the tissue. The study of tissues is known as **Histology**.

**Simple tissue:** A group of cells that are similar in origin, form, structure and work together to perform a specific function.

**Compound tissue:** A group of cells different in their structure and function but co-ordinate to perform a specific function

Animal tissues can be grouped into four basic types on the basis of their structure and functions.

- Epithelial tissue.
- Connective tissue
- Muscular tissue
- Nervous tissue

### 18.2.1 Epithelial Tissues

It is the simplest tissue composed of one or more layers of cells covering the external surface of the body and internal organs. The cells are arranged very close to each other with less extracellular material. Epithelial cells lie on a non-cellular basement membrane. The epithelial tissue generally lacks blood vessels. The epithelium is separated by the underlying connective tissue which provides it with nutrients. There are two types of epithelial tissues. **Simple epithelium** is composed of single layer of cells resting on a basement membrane. **Compound epithelium** is composed of several layers of cells. Only the cells of the deepest layer rest on the basement membrane.

#### Functions of epithelial tissues

- The skin which forms the outer covering of the body protects the underlying cells from drying, injury and microbial infections.
- They help in absorption of water and nutrients.
- They are involved in elimination of waste products.
- Some epithelial tissues perform secretory function (Secretion of sweat, saliva, mucus and enzymes).

#### A. Simple Epithelium

It is formed of **single layer** of cells. It forms a lining for the body cavities and ducts. Simple epithelium is further divided into following types.

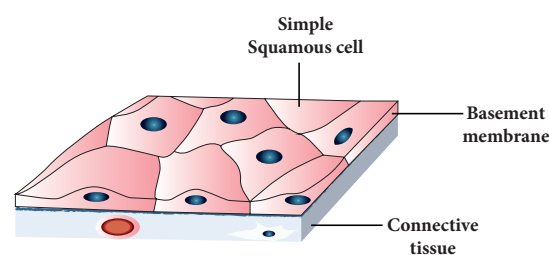

**Figure 18.7** Squamous Epithelium

**Squamous Epithelium:** It is made up of thin, **flat** cells with prominent nuclei. These cells have irregular boundaries and bind with neighbouring cells. The squamous epithelium is also known as **pavement membrane**, which form delicate lining of the buccal cavity, alveoli of lungs, proximal tubule of kidneys and covering of the skin and tongue. It protects the body from mechanical injury, drying and invasion of germs.

**Cuboidal Epithelium:** It is composed of single layer of **cubical** cells. The nucleus is round and lies in the centre. This tissue is present in the thyroid vesicles, salivary glands, sweat glands and exocrine pancreas. It is also found in the intestine and tubular part of the nephron (kidney tubules) as microvilli that increase the absorptive surface area. Their main function is secretion and absorption.

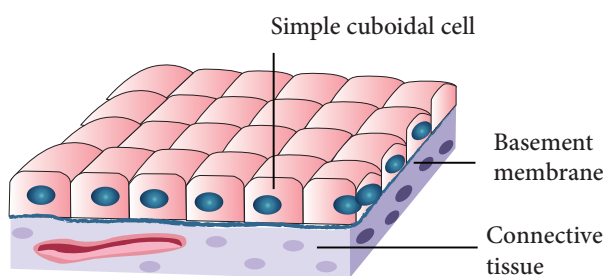

**Figure 18.8** Cuboidal Epithelium

**Columnar Epithelium:** It is composed of a single layer of **slender, elongated** and **pillar** like cells. Their nuclei are located at the base. It is found lining the stomach, gall bladder, bile duct, small intestine, colon, oviducts and also forms the mucous membrane. They are mainly involved in secretion and absorption.

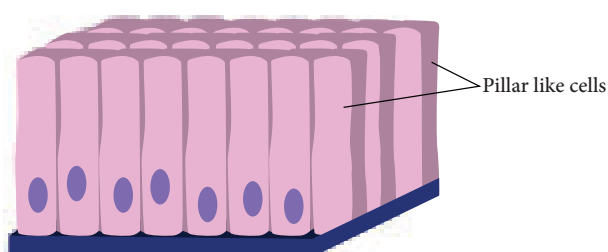

**Figure 18.9** Columnar Epithelium

**Ciliated Epithelium:** Certain columnar cells bear numerous delicate hair like out growths called **cilia** and are called ciliated epithelium. Their function is to move particles or mucus in a specific direction over the epithelium. It is seen in the trachea of wind-pipe, bronchioles of respiratory tract, kidney tubules and fallopian tubes of oviducts.

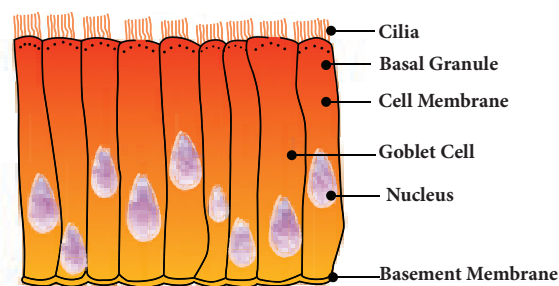

**Figure 18.10** Ciliated Epithelium

**Glandular Epithelium:** Epithelial cells are often modified to form **specialized gland** cells which secrete chemical substances at the epithelial surface. This lines the gastric glands, pancreatic tubules and intestinal glands.

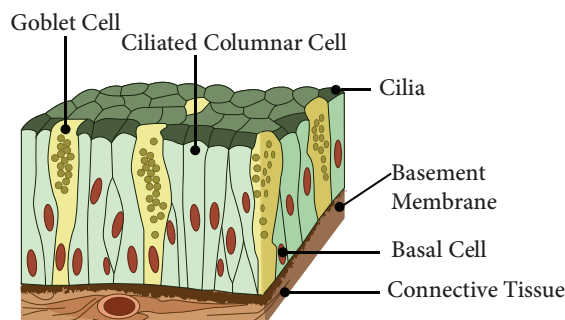

**Figure 18.11** Glandular epithelium

## B. Compound Epithelium

It consists of **more than one layer** of cells and gives a **stratified appearance**. Hence, they are also known as stratified epithelium. The main function of this epithelium is to give protection to the underlying tissues against mechanical and chemical stress. They also cover the dry surface of the skin, the moist surface of the buccal cavity and pharynx.



Epithelial tissue in the skin functions as a water-proof membrane.

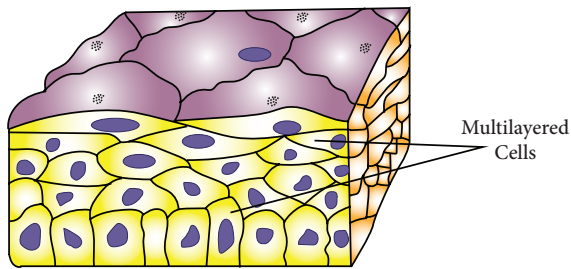

Figure 18.12 Compound Epithelium

### Activity 1

Rinse your mouth with water. Using a tooth pick or ice-cream stick, scrap superficial cells from inner side of the cheek and spread it on a clean glass slide. Dry the glass slide with the scrap cells taken from the inner side of cheek. Add two drops of methylene blue stain. Identify the cells under low and high power of the microscope.

### 18.2.2 Connective Tissues

It is one of the most abundant and widely distributed tissue. It provides **structural framework** and gives **support** to different tissues forming organs. It prevents the organs from getting displaced by body movements.

The components of the connective tissue are the intercellular substance known as the matrix, connective tissue cells and fibres. Connective tissue is classified as follows:

- Connective tissue proper (Areolar and Adipose tissue)
- Supportive connective tissue (Cartilage and Bone)

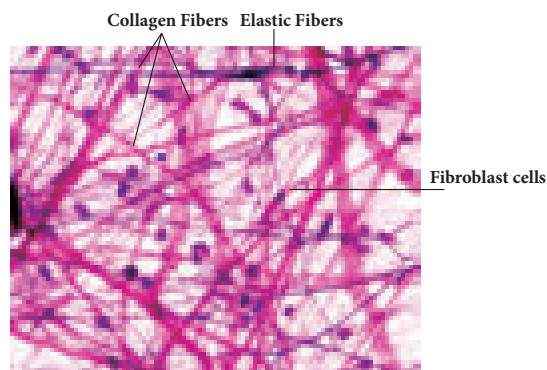

Figure 18.13 Areolar tissue

- Dense connective tissue (Tendons and Ligaments)
- Fluid connective tissue (Blood and Lymph)

#### i. Connective tissue proper:

Connective tissue proper consist of collagen fibres, elastin fibres and fibroblast cells.

**Areolar tissue:** It has cells and fibres loosely arranged in a semi-fluid ground substance called **matrix**. It takes the form of fine threads crossing each other in every direction leaving small spaces called areolae. It joins skin to muscles, fills space inside organs and is found around muscles, blood vessels and nerves. It helps in repair of tissues after injury and fixes skin to underlying muscles.

**Adipose Tissue:** Adipose tissue is the aggregation of **fat cells** or **adipocytes**, spherical or oval in shape. It serves as fat reservoir.

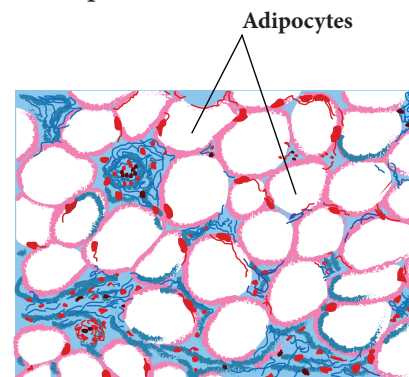

Figure 18.14 Adipose tissue

They are found in subcutaneous tissue, between internal organs around the heart and kidneys. They act as **shock absorbers** around the kidneys and eye balls. They also regulate the body temperature by acting as **insulator**.

#### ii. Supportive Connective Tissue:

The supporting or skeletal connective tissues forms the endoskeleton of the vertebrate body which protect various organs and help in locomotion. The supportive tissues include cartilage and bone.

**Cartilage:** They are soft, semi-rigid, flexible and are less vascular in nature. The matrix is composed of large cartilage cells called **chondrocytes**. These cells are present in fluid filled spaces known as **lacunae**.

Cartilage is present in the tip of the nose, external ear, end of long bones, trachea and larynx. It provides support and flexibility to the body parts.

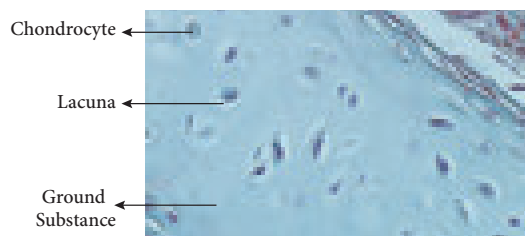

**Figure 18.15** Cartilage

**Bone :** It is solid, rigid and strong, **non-flexible** skeletal connective tissue. The matrix of the bone is rich in calcium salts and collagen fibres which gives the bone its strength. The matrix of the bone is in the form of concentric rings called **lamellae**. The bone cells present in lacunae are called **osteocytes**. They communicate with each other by a network of fine canals called **canaliculi**. The hollow cavities of spaces are called marrow cavities filled with **bone marrow**. They provide shape and structural framework to the body. Bones support and protect soft tissues and organs.

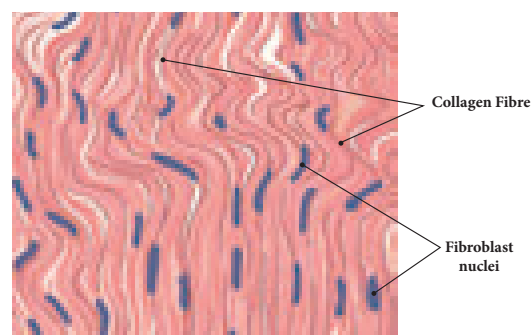

**Figure 18.16** T.S of Bone

### iii. Dense Connective Tissue:

It is a fibrous connective tissue densely packed with fibres and fibroblasts. It is the principal component of tendons and ligaments.

**Tendons:** They are cord like, strong, structures that join skeletal muscles to bones. Tendons have great **strength** and **limited flexibility**. They consist of parallel bundles of collagen fibres, between which are present rows of fibroblasts.



**Figure 18.17** Tendon

**Ligaments:** They are **highly elastic** structures and have great strength which connect bones to bones. They contain very little matrix. They strengthen the joints and allow normal movement.

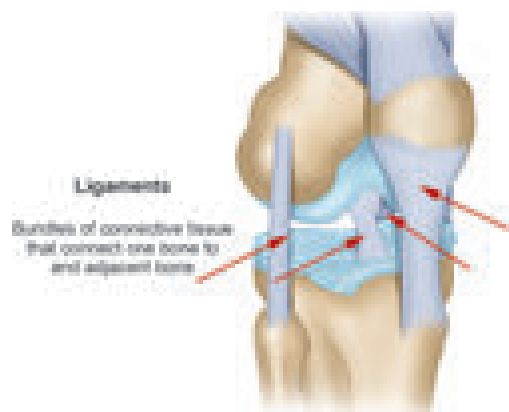

**Figure 18.18** Ligament

**DO YOU KNOW?** Sprain is caused by excessive pulling (stretching) of ligaments.

### iv. Fluid connective tissue:

The blood and the lymph are the fluid connective tissues which link different parts of the body. The cells of the connective tissue are loosely spaced and are embedded in an intercellular matrix.

#### a. Blood

Blood contains corpuscles which are red blood cells (**erythrocytes**), white blood cells (**leucocytes**) and **platelets**. In this fluid connective tissue, blood cells



are present in a fluid matrix called **plasma**. The plasma contains inorganic salts and organic substances. It is a main circulating fluid that helps in the transport of nutrient substances.

**Red blood corpuscles (Erythrocytes):** The red blood corpuscles are circular, biconcave disc-like cells and **lack nucleus** when mature (mammalian RBC). They contain a respiratory pigment called **haemoglobin** which is involved in the transport of oxygen to tissues.

**White blood corpuscles (Leucocytes):** They are larger in size, contain **distinct nucleus** and are **colourless**. They are capable of amoeboid movement and play an important role in body's defense mechanism. They engulf or destroy foreign bodies. WBC's are of two types: Granulocytes and Agranulocytes. **Granulocytes** have irregular shaped nuclei and cytoplasmic granules. They include the **neutrophils, basophils** and **eosinophils**. **Agranulocytes** lack cytoplasmic granules and include the **lymphocytes** and **monocytes**.

**Blood platelets:** They are minute, anucleated, fragile fragments of giant bone marrow called **mega karyocytes**. They play an important role in **blood clotting** mechanism.

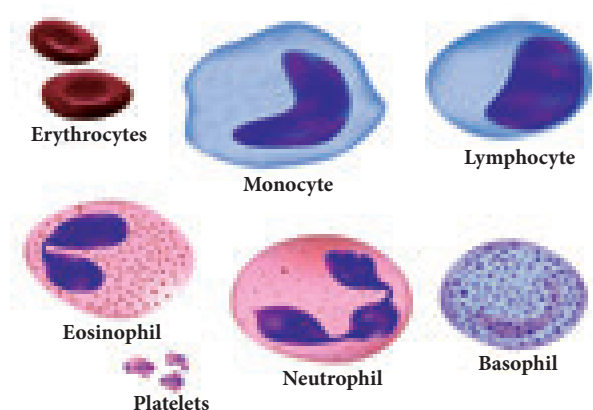

**Figure 18.19** Blood cells

### b. Lymph

Lymph is a colourless fluid filtered out of the blood capillaries. It consists of plasma and white blood cells. It mainly helps in the exchange of materials between blood and tissue fluids.

## 18.2.3 Muscular Tissues

Muscular tissues are made of muscle cells and form the major part of contractile tissue. They are composed of numerous **myofibrils**. Each muscle is made up of many long cylindrical fibres arranged parallel to one another.

According to their structure, location and functions there are three main types of muscles: Skeletal muscle (or) striated muscle, Smooth muscle (or) non-striated muscle and Cardiac muscle.

**Skeletal muscle:** These muscles are attached to the bones and are responsible for the body movements and are called skeletal muscles. They work under our control and are also known as **voluntary muscles**. The muscle fibres are elongated, cylindrical, unbranched with alternating dark and light bands, giving them the **striped** or **striated** appearance. They possess many nuclei (**multinucleate**). For example they occur in the biceps and triceps of arms and undergo rapid contraction.

**Smooth muscle:** These muscles are spindle shaped with broad middle part and tapering ends. There is a single centrally located nucleus (**uninucleate**). These fibrils do not bear any stripes or striations and hence are called **non-striated**. They are not under the control of our will and so are called **involuntary muscles**. The walls of the internal organs such as the blood vessels, gastric glands, intestinal villi and urinary bladder contain this type of smooth muscle.

**Cardiac muscle:** It is a special contractile tissue present in the heart. The muscle fibres are **cylindrical, branched** and **uninucleate**. The branches join to form a network called as **intercalated disc** which are unique distinguishing features of the cardiac muscles. The contraction of cardiac muscle is involuntary and rhythmic.

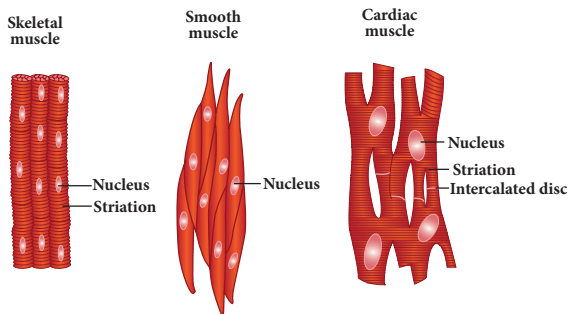

Figure 18.19 Muscle tissue

### 18.2.4 Nervous Tissue

Nervous tissue comprises of the nerve cells or neurons. They are the longest cells of the body. **Neurons** are the structural and functional units of the nervous tissue. The elongated and slender processes of the neurons are the nerve fibres. Each neuron consists of a **cell body** or **cyton** with nucleus and cytoplasm. The **dendrons** are short and highly branched protoplasmic processes of cyton. The **axon** is a single, long fibre like process that develops from the cyton and ends up with fine terminal branches.

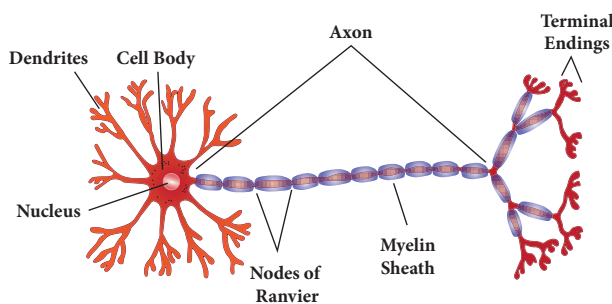

Figure 18.20 Neuron

#### INFO BIT

##### Age of our body cells

- Cells of the eye lens, nerve cells of cerebral cortex and most muscle cells last a life time but once dead are not replaced.
- Epithelial cells lining the gut last only about 5 days.

##### Duration of cell replacement

- Skin cells- about every 2 weeks.
- Bone cells- about every 10 years.
- Liver cells- about every 300 – 500 days.
- Red blood cells last for about 120 days and are replaced.

They have the ability to receive stimuli from within or outside the body and send signals to different parts of the body.



Nerve cells do not undergo cell division due to the absence of centrioles, but they are developed from glial cells by neurogenesis

## 18.3 Cell Division

Are you aware that all living organisms start their life from a single cell? You may wonder how a single cell then goes to form such a large organism. All cells reproduce by division and division of cells into daughter cells is called cell division.

### 18.3.1 Types of Cell Division

The three types of cell division that occur in animal cells are:

- I. Amitosis - Direct Division
- II. Mitosis - Indirect Division
- III. Meiosis - Reduction Division

#### I. Amitosis

It is the simplest mode of cell division and it occurs in unicellular animals, ageing cells and in foetal membranes. During amitosis, nucleus elongates first, and a constriction appears in it which deepens and divides the nucleus into two. Followed by this cytoplasm divides resulting in the formation of two daughter cells.

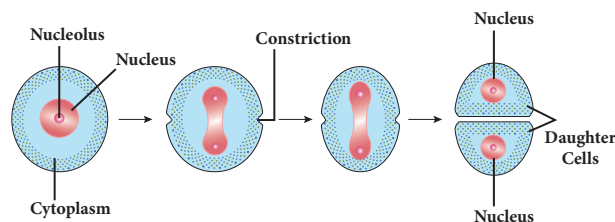
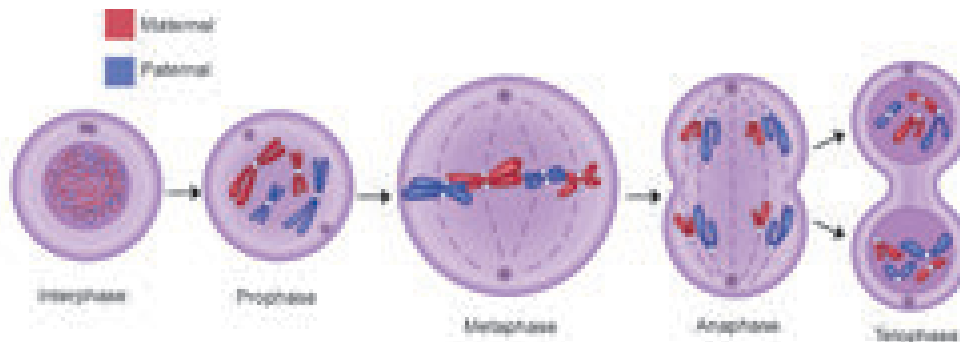

Figure 18.21 Amitosis

#### II. Mitosis

It was first discovered by Fleming in 1879. In this cell division one parent cell divides into two identical daughter cells, each with a nucleus having the same amount of DNA,



**Figure 18.22** Events of Mitosis

same number of chromosomes and genes as the parent cells. It is also called as **equational division**. Mitosis consists of two events, they are: 1. Karyokinesis 2. Cytokinesis

**Interphase:** It is the **resting phase** of the nucleus. It is the interval between two successive cell divisions. The cell prepares itself for the next cell division.

### 1. Karyokinesis

The division of the nucleus into two daughter nuclei is called Karyokinesis. It consists of four phases. They are: Prophase, Metaphase, Anaphase and Telophase.

**Prophase (pro-first):** During this stage chromosomes become short and thick and are clearly visible inside the nucleus. Centrosome splits into centrioles and occupy opposite poles of the cell. Each centriole is surrounded by **aster rays**. Spindle fibres appear between the two centrioles. Nuclear membrane and nucleolus disappear gradually.

**Metaphase (meta – after):** The duplicated chromosomes arrange on the equatorial plane and form the metaphase plate. Each chromosome gets attached to a spindle fibre by its centromere. The centromere of each chromosome divides into two each being associated with a chromatid.

**Anaphase (ana – up, back):** The centromeres attaching the two chromatids divide and the two daughter chromatids of each chromosome separate and migrate towards the two opposite poles.

**Telophase (tele – end):** Each chromatid (or) daughter chromosome lengthens, becomes

thinner and turns into a network of chromatin threads. Spindle fibres breakdown and disappear. Nuclear membrane and nucleolus reappear in each daughter nucleus.

### 2. Cytokinesis

The division of the cytoplasm into two daughter cells by constriction of the cell membrane is called cytokinesis.

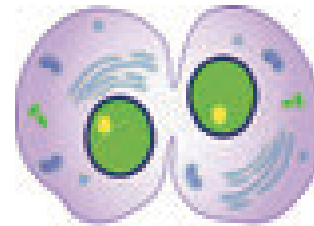

**Figure 18.23** Cytokinesis

### Significance of Mitosis

1. This equational division results in the production of diploid daughter cells ( $2n$ ) with equal distribution of genetic material (DNA).
2. In multicellular organisms growth, organ development and increase in body size are accomplished through the process of mitosis
3. Mitosis helps in repair of damaged and wounded tissues by renewal of the lost cells.

### III. Meiosis

The term meiosis was coined by Farmer in 1905. It is the kind of cell division that produces the sex cells or the gametes. It is also called reduction division because the chromosome number is reduced to haploid ( $n$ ) from diploid ( $2n$ ). Meiosis produces four daughter cells from a parent cell.



Meiosis consists of two divisions. They are:

- **Heterotypic Division** or First Meiotic Division
- **Homotypic Division** or Second Meiotic Division

### A. Heterotypic division

It divides the diploid cell into two haploid cells. The daughter cells resulting from this division are different from the parent cell in the chromosome number (Heterotypic). This consists of 5 stages:

- |                  |                |
|------------------|----------------|
| a. Prophase I    | b. Metaphase I |
| c. Anaphase I    | d. Telophase I |
| e. Cytokinesis I |                |

#### a. Prophase I

Prophase I takes a longer duration and is sub divided into five stages. They are: Leptotene, Zygotene, Pachytene, Diplotene and Diakinesis.

**Leptotene:** The chromosomes become uncoiled and assume long thread like structures and take up a specific orientation inside the nucleus. They form a **bouquet stage**.

**Zygotene (Zygon-adjointing):** Two homologous chromosomes approach each other and begin to pair. Pairing of homologous chromosomes is called as **synapsis**.

**Pachytene (Pachus-thick):** The chromosomes are visible as long paired twisted threads. The pairs so formed are called **bivalents**. Each bivalent now contains four chromatids (**tetrad stage**).

Homologous chromosomes of each pair begin to separate. They do not completely separate, but remain attached together at one or more points by X-shaped arrangements known as **chiasmata**. The chromatids break at these points and the broken segments may be interchanged (crossing over). As a result, the **genetic recombination** takes place.

**Diplotene:** Each individual chromosome of each bivalent begins to split longitudinally into two similar chromatids. The homologous chromosomes repel each other and separate. Chiasmata begin to move along the length of the chromosome from the centromere towards the end resulting in **terminalization**.

**Diakinesis:** The paired chromosomes are shortened and thickened. The nuclear membrane and nucleolus begin to disappear. Spindle fibres make their appearance.

#### b. Metaphase I

The chromosomes move towards the equator and finally they orient themselves on the equator. The two chromatids of each chromosome do not separate. The centromere does not divide.

#### c. Anaphase I

Each homologous chromosome with its two chromatids and undivided centromere move towards the opposite poles of the cell. This stage of the chromosome is called **Diad**.

#### d. Telophase I

The haploid number of chromosomes after reaching their respective poles become uncoiled

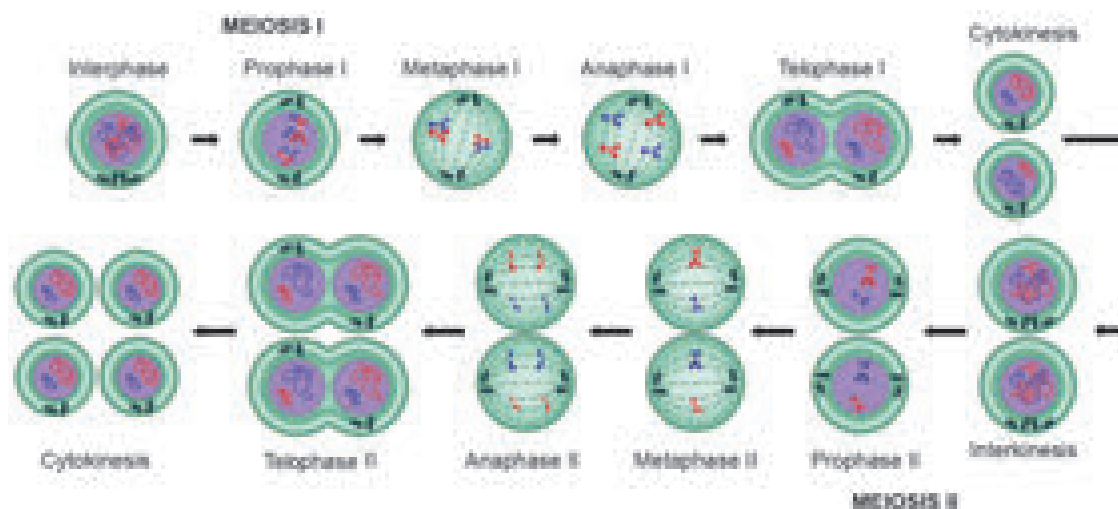

**Figure 18.24** Events of Meiosis

and elongated. The nuclear membrane and the nucleolus reappear and thus two daughter nuclei are formed.

**e. Cytokinesis I:** The cytoplasmic division occurs and two haploid cells are formed.

### B. Homotypic Division

In this division, the two haploid cells formed during first meiotic division divide into four haploid cells. The daughter cells are similar to parent cell in the chromosome number (Homotypic). It consists of five stages.

- a. Prophase – II
- b. Metaphase – II
- c. Anaphase – II
- d. Telophase – II
- e. Cytokinesis – II

**a. Prophase II:** The centriole divides into two, each one moves to opposite poles. Asters and spindle fibres appear. Nuclear membrane and nucleolus disappear.

**b. Metaphase II:** The chromosomes get arranged on the equator. Two chromatids are separated.

**c. Anaphase II:** The separated chromatids become daughter chromosomes and move to opposite poles

**d. Telophase II:** The daughter chromosomes are centered. The nuclear membrane and the nucleolus appear.

**e. Cytokinesis II:** Two cells are formed from each haploid daughter cell, resulting in the formation of four cells with haploid number of chromosomes.

### Significance of Meiosis

- The constant number of chromosomes in a given species is maintained by meiotic division.
- Genetic variation is produced due to crossing over within the species which is transmitted from one generation to next generation.

**Table 18.3** Differences between Mitosis and Meiosis

Mitosis	Meiosis
Occurs in somatic cells.	Occurs in reproductive cells.
Involved in growth and occurs continuously throughout life.	Involved in gamete formation only during the reproductively active age.
Consists of single division.	Consists of two divisions.
Two diploid daughter cells are formed.	Four haploid daughter cells are formed.
The chromosome number in the daughter cell is similar to the parent cell (2n).	The chromosome number in the daughter cell is just half (n) of the parent cell.
Identical daughter cells are formed.	Daughter cells are not similar to the parent cell and are randomly assorted.

### Points to Remember

- ❖ In general plant tissues are classified into two types namely Meristems or Meristematic tissues and Permanent tissues.
- ❖ Permanent tissues are of two types: simple tissue and complex tissue.
- ❖ Simple tissues are homogeneous-composed of structurally and functionally similar cells. eg., Parenchyma, Collenchyma and Sclerenchyma.
- ❖ Complex tissues are made of more than one type of cells that work together as a unit. They are Xylem and Phloem

- ❖ Animal tissues can be grouped into four basic types on the basis of their structure and functions. Epithelial tissue, Connective tissue, Muscular tissue and Nervous tissue.
- ❖ Simple epithelium formed of single layer of cells is divided into following types. They are squamous epithelium cuboidal epithelium, columnar epithelium, ciliated epithelium and glandular epithelium
- ❖ Compound Epithelium consists of more than one layer of cells and gives a stratified appearance.
- ❖ The three types of cell division that occur in animal cells are Amitosis, Mitosis and Meiosis.

## A-Z GLOSSARY

<b>Bivalent</b>	Homologous chromosomes before their duplication in meiosis.
<b>Centromere</b>	kinetochore or primary constriction.
<b>Chiasma</b>	Point of contact and interchange between chromatids of two homologous chromosomes.
<b>Chromatids</b>	Two identical longitudinal halves of a chromosome which share a common centromere with a sister chromatid.
<b>Diploid</b>	Cell having two complete sets of chromosomes.
<b>Haploid</b>	Cell having a single complete set of chromosome.
<b>Interphase</b>	Resting phase of the cell between two cell divisions.
<b>Isodiametric</b>	Having equal diameter of cells or other structures.
<b>Osteocytes</b>	Bone cells present between the lamellae in fluid filled spaces called lacunae.
<b>Synapsis</b>	Pairing of homologous chromosomes during meiosis.
<b>Tetrad</b>	Four haploid cells arising from meiosis formed from four associated chromatids during synapsis.



## TEXTBOOK EXERCISES



### I. Choose the correct answer.

- The tissue composed of living thin walled polyhedral cell is
  - parenchyma
  - pollenchyma
  - pclerenchyma
  - None of above
- The fibres consists of
  - parenchyma
  - sclerenchyma
  - collenchyma
  - None of above
- Companion cells are closely associated with
  - sieve elements
  - vessel elements
  - trichomes
  - guard cells.
- Which of the following is a complex tissue?
  - Parenchyma
  - Collenchyma
  - Xylem
  - Sclerenchyma
- Aerenchyma is found in
  - epiphytes
  - hydrophytes
  - halophytes
  - xerophytes
- Smooth muscles occur in
  - uterus
  - artery
  - vein
  - All of the above.

- Nerve cell does not contains

- axon
- nerve endings
- tendons
- dendrites

### II. Match the following.

Sclereids	Chlorenchyma
Chloroplast	Sclerenchyma
Simple tissue	Collenchyma
Companion cell	Xylem
Trachieds	Phloem

### III. Fill in the blanks.

- \_\_\_\_\_ tissues provide mechanical support to organs.
- Parenchyma, collenchyma, Sclerenchyma are \_\_\_\_\_ type of tissue.
- \_\_\_\_\_ and \_\_\_\_\_ are complex tissues.
- Epithelial cells with cilia are found in \_\_\_\_\_ of our body.
- Lining of small intestine is made up of \_\_\_\_\_.

#### IV. State whether true or false. If false, correct the statement.

1. Epithelial tissue is protective tissue in animal body.
2. Bone and cartilage are two types of areolar connective tissues.
3. Parenchyma is a simple tissue.
4. Phloem is made up of tracheids.
5. Vessels are found in collenchyma.

#### V. Answer briefly.

1. What are intercalary meristems? How do they differ from other meristems?
2. What is complex tissue? Name the various kinds of complex tissues.
3. Mention the most abundant muscular tissue found in our body. State its function.
4. What is skeletal connective tissue? How is it helpful in the functioning of our body?
5. Why should gametes be produced by meiosis during sexual reproduction?
6. In which stage of mitosis the chromosomes align in an equatorial plate? How?

#### VI. Answer in detail.

1. What are permanent tissues? Describe the different types of simple permanent tissues.
2. Write about the elements of Xylem.
3. List out the differences between mitosis and meiosis.

#### VII. Higher Order Thinking Skills.

1. What is the consequence that occur if all blood platelets are removed from the blood?
2. Which are not true cells in the blood? Why?



#### REFERENCE BOOKS

1. Pandey B.P. -Plant Anatomy. S.Chand and Company Ltd, New Delhi.
2. Verma P.S. and Agarwal V.K. -Cytology. S.Chand and Company Ltd, New Delhi.



#### INTERNET RESOURCES

- <https://www.britannica.com/science>  
<https://biologydictionary.net>

### Concept Maps

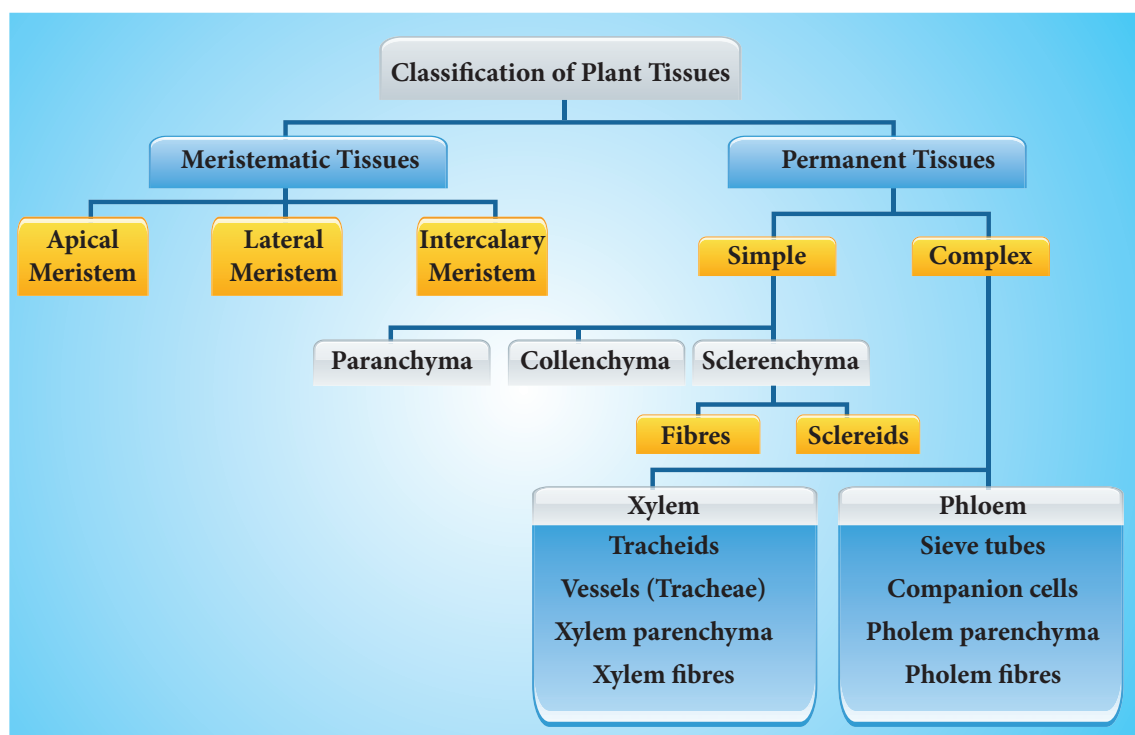

## Classification of Animal Tissues

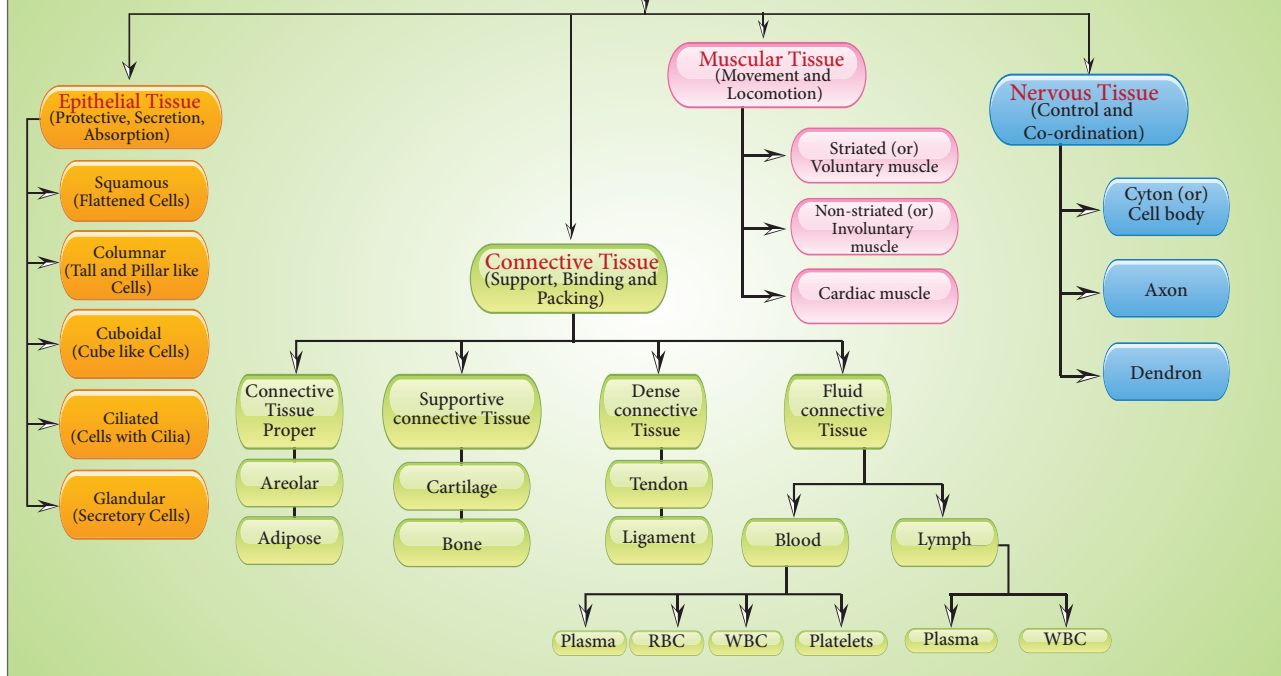

## ICT CORNER

## Tissues and Organs

Explore this activity to know about the various types of tissues.

- Step 1:** Copy and paste the link given below or type the URL in the browser. Allow 'Adobe Flash Player' to run in the system.
- Step 2:** Then choose an organ from the list to know about the tissues that are in a particular organ.
- Step 3:** Keep selecting the tissues by clicking the 'Use this' option, if you need that particular tissue for that organ.
- Step 4:** Once you finish selecting the tissues you will find a pop-up called 'Happy with this choice.' Click on it to know whether your choice is correct or you should try again. In this way you can build different organs.

### Browse in the link:

URL: <https://www.centreofthecell.org/learn-play/games/build-an-organ/>



## Learning Objectives

After completing this lesson, students will be able to:

- know that plants too have certain autonomic movements.
- understand different types of movement in plants.
- differentiate tropic movement from nastic movement.
- gain knowledge on transpiration.
- understand that plants produce their food through the process of photosynthesis.
- understand the process of transpiration.



## Introduction

Animals move in search of food, shelter and for reproduction. Do plants show such movement? Have you observed the leaves of *Mimosa pudica* (touch-me-not plant) closes on touching, whereas *Helianthus annuus* (sunflower) follows the path of the sun from dawn to dusk, (from east to west). These movements are triggered by an external stimuli. Unlike animals, plants do not move on their own from one place to another, but can move their body parts for getting sunlight, water and nutrients. They are sensitive to external factors like light, gravity, temperature etc. In this lesson, we will study about various movements in plants, photosynthesis and transpiration.

### 19.1 Tropism in Plants

Tropism is a unidirectional movement of a whole or part of a plant towards the direction of stimuli.

#### 19.1.1 Types of Tropism

Based on the nature of stimuli, tropism can be classified as follows.

**Phototropism:** Movement of a plant part towards light. e.g. shoot of a plant.

**Geotropism:** Movement of a plant in response to gravity. e.g. root of a plant.

**Hydrotropism:** Movement of a plant or part of a plant towards water. e.g. root of a plant.

**Thigmotropism:** Movement of a plant part due to touch. e.g. climbing vines.

**Chemotropism:** Movement of a part of plant in response to chemicals. e.g. growth of a pollen tube in response to sugar present on the stigma.

Tropism is generally termed **positive** if growth is **towards the signal** and **negative** if it is **away from the signal**.

Shoot of a plant moves towards the light, the roots move away. Thus the shoots are **positively phototropic**.



**Figure 19.1** Positive phototropism (Negatively geotropic)

Usually shoot system of a plant is positively phototropic and negatively geotropic and root system is negatively phototropic and positively geotropic.



**Figure 19.2** Negative phototropism (Positively geotropic)



Some halophytes produce negatively geotropic roots (e.g. *Rhizophora*). These roots turn 180° upright for respiration.

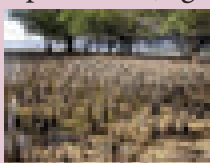

## 19.2 Nastic Movements

Nastic movements are non-directional response of a plant or part of a plant to stimulus. Based on the nature of stimuli, nastic movements are classified as follows.

### Activity 1

Take a glass trough and fill it with sand. Keep a flower pot containing water, plugged at the bottom at the centre of the glass trough. Place some soaked pea or bean seeds around the pot in the sand. What do you observe after 6 or 7 days? Record your observation.

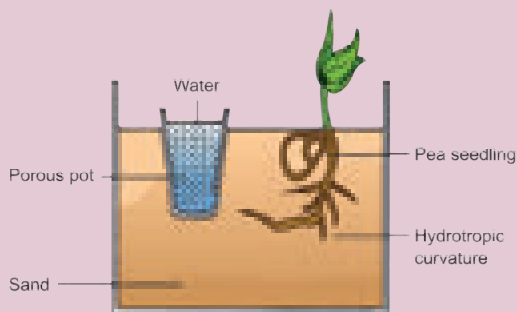

### Activity 2

Take pea seeds soaked in water overnight. Wait for the pea seeds to germinate. Once the seedling has grown put it in a box with an opening for light on one side. After few hours, you can clearly see how the stem has bent and grown towards the light.

**Photonasty:** Movement of a part of a plant in response to light. e.g. *Taraxacum officinale*, blooms in morning and closes in the evening. Similarly, *Ipomea alba* (Moon flower), opens in the night and closes during the day.



Night

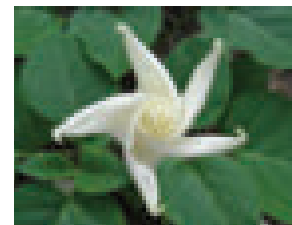

Day

**Figure 19.3** Photonasty in Moon flower

**Thigmonasty:** Movement of a part of plant in response to touch. e.g. *Mimosa pudica*, folds leaves and droops when touched. It is also known as Seismonasty.

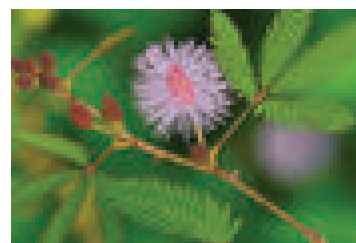

**Figure 19.4** Thigmonasty in *Mimosa pudica*



The Venus Flytrap (*Dionaea muscipula*) presents a spectacular example of thigmonasty. It exhibits one of the fastest known nastic movements.

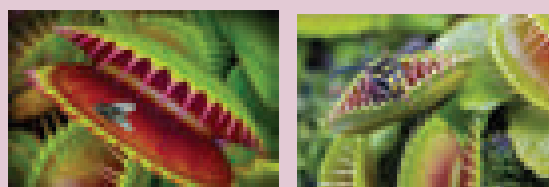

**Table 19.1** Differences between Tropic and Nastic movements

Tropic movements	Nastic movements
Unidirectional response to the stimulus.	Non-directional response to the stimulus.
Growth dependent movements.	Growth independent movements.
More or less permanent and irreversible.	Temporary and reversible.
Found in all plants.	Found only in a few specialized plants.
Slow action.	Immediate action.

**Thermonasty:** Movement of part of a plant is associated with change in temperature. e.g. *Tulip* flowers bloom as the temperature increases.

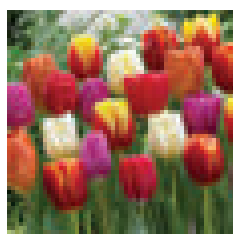

**Figure 19.5** Thermonasty in Tulip

## 19.3 Photosynthesis

'Photo' means 'light' and 'synthesis' means 'to build'. Thus photosynthesis literally means 'building up with the help of light'. During this process, the light energy is converted into chemical energy. Green plants are autotrophic in their mode of nutrition because they prepare their food materials through a process called photosynthesis. The overall equation of photosynthesis can be given as below:

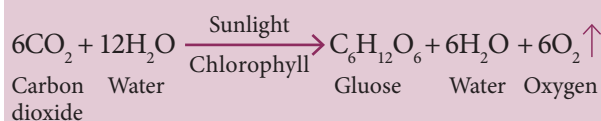

**Do the insects also trap solar energy?** Tel Aviv University Scientists have found out that *Vespa orientalis* (Oriental Hornets) have similar capabilities to trap solar energy. They have a yellow patch on its abdomen and an unusual cuticle structure which is a stack of 30 layers thick. The cuticle does not contain chlorophyll but it contains the yellow light sensitive pigment called xanthopterin. This works as a light harvesting molecule transforming light energy into electrical energy.

The end product of photosynthesis is glucose which will be converted into starch and stored in the plant body. Plants take in carbon dioxide for photosynthesis; but for its living, plants also need oxygen to carry on cellular respiration.

### 19.3.1 Requirements for Photosynthesis'

#### Activity 3

Pluck a variegated leaf from *Coleus* plant kept in sunlight. De-starch it by keeping in dark room for 24 hours. Draw the picture of this leaf and mark the patches of chlorophyll on the leaf. Immerse the leaf in boiling water followed by alcohol and test it for starch using iodine solution. Record your observation.

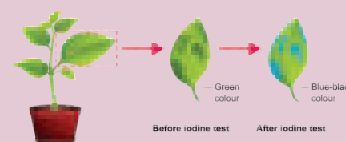

#### Activity 4

Place a potted plant in a dark room for about 2 days to de-starch its leaves. Cover one of its leaves with the thin strip of black paper as shown in the picture. make sure that the leaf is covered on both sides. Keep the potted plant in bright sunlight for 4 to 6 hours. Pluck the selected covered leaf and remove the black paper. Immerse the leaf in boiling water for a few minutes and then in alcohol to remove chlorophyll. Test the leaf now with iodine solution for the presence of starch. The covered part of the leaf does not turn blue-black whereas the uncovered part of the leaf turns blue-black colour. Why are the changes in colour noted in the covered and uncovered part of the leaf?





These activities show that certain things are necessary for photosynthesis. They are:

1. Chlorophyll - Green pigment in leaves
2. Water
3. Carbon dioxide (from air)
4. Sun light

## 19.4 Transpiration

The loss of water in the form of water vapour from the aerial parts of the plant body is called as transpiration. The leaves have tiny, microscopic pores called **stomata**. Water evaporates through these stomata. Each stomata is surrounded by guard cells. These guard cells help in regulating the rate of transpiration by opening and closing of stomata.

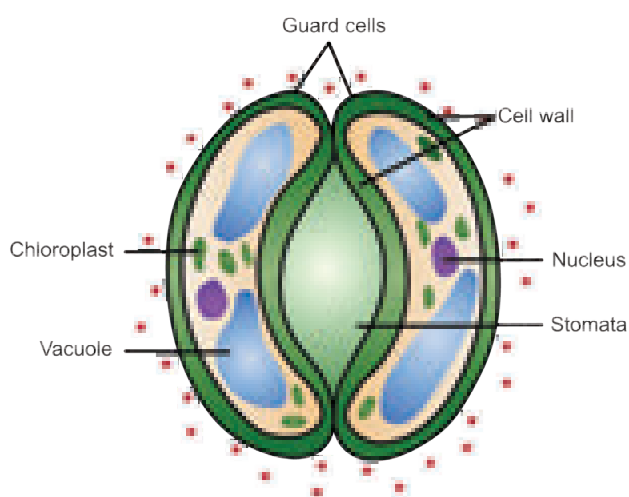

Figure 19.6 Structure of Stomata

### 19.4.1 Types of Transpiration

There are three types of transpiration:

**Stomatal transpiration:** Loss of water from plants through stomata. It accounts for 90-95% of the water transpired from leaves.

**Cuticular transpiration:** Loss of water in plants through the cuticle.

**Lenticular transpiration:** Loss of water from plants as vapour through the lenticels. The lenticels are tiny openings that protrude from the barks in woody stems and twigs as well as in other plant organs.

But transpiration is necessary for the following reasons.

1. It creates a pull in leaf and stem.
2. It creates an absorption force in roots.
3. It is necessary for continuous supply of minerals.
4. It regulates the temperature of the plant.

### Activity 5

Take a plastic bag and tie it over a leaf and place the plant in light. You can see water condensing inside the plastic bag. The water is let out by the leaves. Why does this occur?

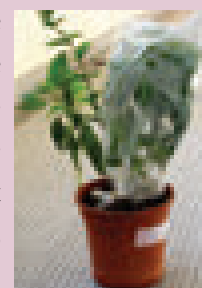

### 19.4.2 Exchange of Gases

How does the plant get air? The leaves have minute pores called **stomata** through which the exchange of air takes place. These minute pores can be seen through a microscope. Air exchange takes place continuously through the stomata. Plants exchange gases ( $\text{CO}_2$  to  $\text{O}_2$ ) continuously through these stomata. You will study more about these physiological process in your higher classes.

#### Points to Remember

- ❖ Growth movement whose direction is determined by the direction of the stimulus is called Tropism.
- ❖ Non-directional, response of a plant part to stimulus is called nastic movement.
- ❖ The process by which plants prepare their food material is called photosynthesis.
- ❖ The loss of water in the form of water vapour from the aerial parts of the plant body is called transpiration.
- ❖ Stomata are minute opening on the leaves.

## A-Z GLOSSARY

<b>Phototropism</b>	Unidirectional movement of a plant part to light stimulus.
<b>Geotropism</b>	Response of a plant part to gravity stimulus.
<b>Hydrotropism</b>	Response of a plant part to water stimulus.
<b>Thigmotropism</b>	Response of a plant part to touch stimulus.
<b>Chemotropism</b>	Response of a plant part to chemical stimulus.
<b>Thigmonasty</b>	Non-directional movement of a plant part in response to touch of an stimulus.
<b>Photonasty</b>	Non-directional movement of a plant part in response to light stimulus.



## TEXTBOOK EXERCISES



### I. Choose the correct answer.

- The tropic movement that helps the climbing vines to find a suitable support is \_\_\_\_\_.  
a. Phototropism      b. Geotropism  
c. Thigmotropism    d. Chemotropism
- The chemical reaction occurs during photosynthesis is \_\_\_\_\_.  
a.  $\text{CO}_2$  is reduced and water is oxidized  
b. water is reduced and  $\text{CO}_2$  is oxidized  
c. both  $\text{CO}_2$  and water are oxidized  
d. both  $\text{CO}_2$  and water are produced
- The bending of root of a plant in response to water is called \_\_\_\_\_.  
a. Thigmonasty      b. Phototropism  
c. Hydrotropism    d. Photonasty
- A growing seedling is kept in the dark room. A burning candle is placed near it for a few days. The tip part of the seedling bends towards the burning candle. This is an example of \_\_\_\_\_.  
a) Chemotropism    b) Geotropism  
c) Phototropism    d) Thigmotropism
- The root of the plant is \_\_\_\_\_.  
i) positively phototropic but negatively geotropic  
ii) positively geotropic but negatively phototropic  
iii) negatively phototropic but positively hydrotropic  
iv) negatively hydrotropic but positively phototropic  
a) (i) and (ii)      b) (ii) and (iii)  
c) (iii) and (iv)    d) (i) and (iv)
- The non-directional movement of a plant part in response to temperature is called \_\_\_\_\_.  
a) Thermotropism    b) Thermonasty  
c) Chemotropism    d) Thigmonasty
- Chlorophyll in a leaf is required for \_\_\_\_\_.  
a) photosynthesis    b) tropic movement  
c) transpiration    d) nastic movement
- Transpiration takes place through \_\_\_\_\_.  
a) fruit    b) seed    c) flower    d) stomata

## II. Fill in the blanks.

1. The shoot system grows upward in response to \_\_\_\_\_
2. \_\_\_\_\_ is positively hydrotropic as well as positively geotropic.
3. The green pigment present in the plant is \_\_\_\_\_
4. The solar tracking of sunflower in accordance with the path of sun is due to \_\_\_\_\_.
5. The response of a plant part towards gravity is \_\_\_\_\_.
6. Plants take in carbon dioxide for photosynthesis but need \_\_\_\_\_ for their living.

## III. Match column A with column B.

Column A	Column B
Roots growing downwards into soil.	Positive phototropism
Shoots growing towards the light.	Negative geotropism
Shoots growing upward.	Negative phototropism
Roots growing downwards away from light.	Positive geotropism

## IV. State whether true or false. If false, correct the statement.

1. The response of a part of plant to the chemical stimulus is called phototropism.
2. Shoot is positively phototropic and negatively geotropic.
3. When the weather is hot, water evaporates lesser which is due to opening of stomata.
4. Photosynthesis produces glucose and carbon dioxide.
5. Photosynthesis is important in releasing oxygen to keep the atmosphere in balance.
6. Plants lose water when the stomata on leaves are closed.

## V. Answer very briefly.

1. What is nastic movement?
2. Name the plant part
  - a) Which bends in the direction of gravity but away from the light.
  - b) Which bends towards light but away from the force of gravity.
3. Differentiate phototropism from photonasty.
4. Photosynthesis converts energy X into energy Y.
  - a) What are X and Y?
  - b) Green plants are autotrophic in their mode of nutrition. Why?
5. Define transpiration.
6. Name the cell that surrounds the stoma.

## VI. Answer briefly.

1. Give the technical terms for the following:
  - a) Growth dependent movement in plants.
  - b) Growth independent movement in plants.
2. Explain the movement seen in Pneumatophores of Avicennia.
3. Fill in the blanks:
$$6\text{CO}_2 + \text{---} \xrightarrow[\text{Chlorophyll}]{\text{Sunlight}} \text{---} + 6\text{O}_2 \uparrow$$
4. What is chlorophyll?
5. Name the part of plant which shows positive geotropism. Why?
6. What is the difference between movement of flower in sunflower plant and closing of the leaves in the *Mimosa pudica*?

- Suppose you have a rose plant growing in a pot, how will you demonstrate transpiration in it?
- Mention the differences between stomatal and lenticular transpiration
- To which directional stimuli do (a) roots respond (b) shoots respond?

### VII. Answer in detail.

- Differentiate between tropic and nastic movements
- How will you differentiate the different types of transpiration?

### VIII. Higher Order Thinking Skills.

- There are 3 plants A, B and C. The flowers of A open their petals in bright light during the day but closes when it gets dark at night. On the other hand, the flowers of plant B open their petals at night but closes during the day when there is bright light. The leaves of plant C fold up and droop when touched with fingers or any other solid object.
  - Name the phenomenon shown by the flowers of plant A and B.
  - Name one plant each which behaves like the flowers of plant A and B.
  - Name the phenomenon exhibited by the leaves of plant C.
  - Name the plant which behaves like the leaves of plant 'C'?

- Imagine that student A studied the importance of certain factors in photosynthesis. He took a potted plant and kept it in dark for 24 hours. In the early hours of the next morning, he covered one of the leaves with dark paper in the centre only. Then he placed the plant in sunlight for a few hours and tested the leaf which was covered with black paper for starch.
  - What aspect of photosynthesis was being investigated?
  - Why was the plant kept in the dark before the experiment?
  - How will you prove that starch is present in the leaves?
  - Name the raw materials needed for photosynthesis.



### REFERENCE BOOKS

- Devlin and Witham, 1986. Plant Physiology, 1st edition
- B.P. Pandey 2003 Modern Practical Botany Vol. II.
- V.K. Jain 2003 Plant physiology.



### INTERNET RESOURCES

- <http://web.mit.edu/esgbio>  
<http://www.bioedonline.org/>  
<http://www.biology.arizona.edu/default.html>

### Concept Map

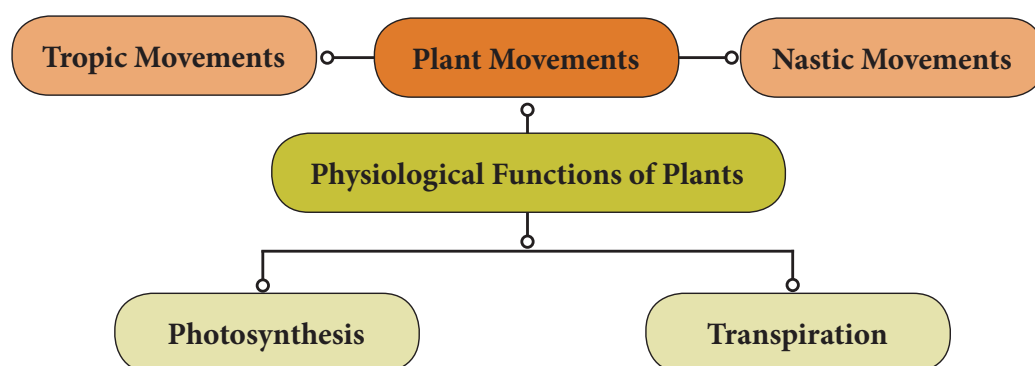

### Learning Objectives

After completing this lesson, student will be able to:

- define the terms digestion, excretion and reproduction.
- understand the various parts of the alimentary canal and the process of digestion.
- understand the role of enzymes in the process of digestion.
- know the organs involved in the process of excretion.
- understand the role of skin in excretion.
- understand the parts and functions of excretory system.
- learn the functions of male and female human reproductive system.



### Introduction

Living organisms are evolved from the simplest form to complex level of organization. Cells are the basic fundamental units of an organism. These are grouped to form tissues, the tissues into organs and the organs form the organ systems forming an entire organism. The different organs and organ systems of an organism function by depending on one another with harmonious coordination. When we ride a bicycle, our muscular system and skeletal system work together to move our arms for steering and legs for pedalling. Our nervous system directs our arms and legs to work. Simultaneously, respiratory, digestive and circulatory systems work to provide energy to the muscles. All the systems work together in coordination to maintain

the body in a homeostatic condition of an organism.

Organ and organ systems have appeared first in the Phylum platyhelminthes and continues till mammals. Similar groups of cells form tissues like muscle tissue, nervous tissue, etc. Tissues are organised to form organs like heart, brain, etc. Two or more organs together form organ systems and perform common functions like digestion, circulation, nerve impulse transmission in coordination via digestive system, circulatory system, nervous system respectively. Division of labour is found among the various organ systems.

In this chapter we shall learn about the structure and functions of various organ systems like digestive system, excretory system and reproductive system in human beings.

**Table 20.1** Organ Systems in Animals

Organ Systems	Organs	Functions
<b>Integumentary system</b>	Skin and skin glands	Protection, Excretion, etc.
<b>Skeletal system</b>	Skull, Vertebral column, Sternum, Girdles and Limbs	Give support, shape and form to the body.
<b>Muscular system</b>	Muscle fibres	Contraction and relaxation resulting movement.
<b>Nervous system</b>	Brain, spinal cord and nerves.	Conduction of nerve impulse.
<b>Circulatory system</b>	Heart, blood and blood vessels	Transportation of respiratory gases, nutritive substances and waste products.
<b>Respiratory system</b>	Respiratory tract and Lungs	Breathing
<b>Digestive system</b>	Digestive tract and digestive glands	Digestion, Absorption, Egestion
<b>Excretory system</b>	Kidneys, ureters, urinary bladder and urethra.	Elimination of nitrogenous waste products.
<b>Reproductive system</b>	Testes and ovary	Gamete formation and development of secondary sexual characters.
<b>Sensory system</b>	Eyes, nose, ears, tongue and skin	Sight, smell, hearing, taste and touch.
<b>Endocrine system</b>	Pituitary, Thyroid, Parathyroid, Adrenals, Pancreas, Pineal body, Thymus, Reproductive glands, etc.	Co-ordinates the functions of all organ systems.

## 20.1 Human Digestive System

The food we eat contain not only simple substances like vitamins and minerals but also complex substances such as carbohydrates, proteins and fats. The body cannot use these complex substances unless they are converted into simple substances. The five stages of nutrition process include ingestion, digestion, absorption, assimilation and egestion.

The process of nutrition begins with intake of food, called **ingestion**. The breakdown of large complex insoluble food molecules into small, simpler soluble and diffusible particles by the action of digestive enzymes is called **digestion**. Parts of the body concerned with the digestion of food form the **digestive system**.

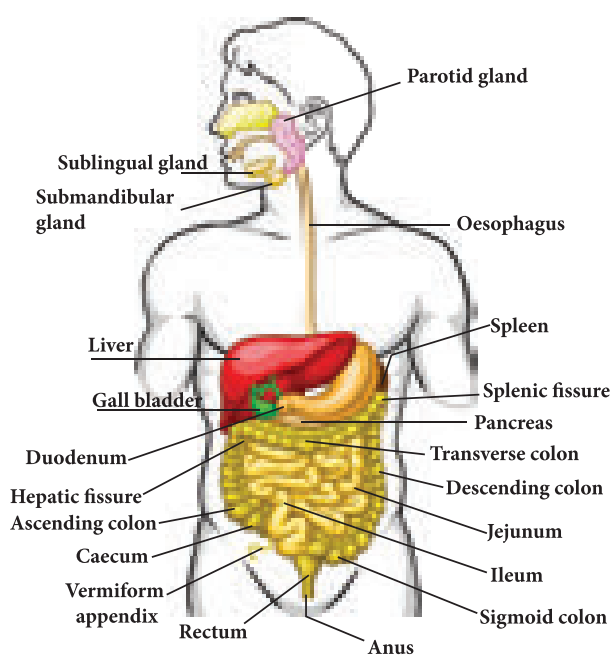

**Figure 20.1** Parts of human digestive system

The digestive system consists of two sets of organs. They are as follows:

**Alimentary canal (digestive tract/gastro-intestinal tract):** It is a passage starting from the mouth and ending with the anus.

**Digestive glands:** Glands associated with the alimentary canal are the salivary glands, gastric glands, pancreas, liver and intestinal glands.

### 20.1.1 Structure of the Alimentary Canal

Alimentary canal is a muscular coiled, tubular structure. It consists of mouth, buccal cavity, pharynx, oesophagus, stomach, small intestine (consisting of duodenum, jejunum and ileum), large intestine (consisting of caecum, colon and rectum) and anus.

**Mouth:** The mouth leads into the buccal cavity. It is bound by two soft, movable upper and lower lips. The **buccal cavity** is a large space bound above by the palate (which separates the wind pipe and food tube), below by the throat and on the sides by the jaws. The jaws bear teeth.

**Teeth:** Teeth are hard structures meant for holding, cutting, grinding and crushing the food. In human beings two sets of teeth (**Diphyodont**) are developed in their life time. The first appearing set of 20 teeth called temporary or milk teeth are replaced by the second set of thirty two permanent teeth, sixteen in each jaw. Each tooth has a root fitted in the gum (**Thecodont**). Permanent teeth are of four types (**Heterodont**), according to their structure and function namely **incisors, canines, premolars and molars**.

**Table 20.2** Types of teeth and their functions

Types of teeth	Number of teeth	Functions
Incisors	8	Cutting and biting
Canines	4	Tearing and piercing
Premolars	8	Crushing and grinding
Molars	12	Crushing, grinding and mastication

Dental formula represents the number of different type of teeth present in each half of a jaw (upper and lower jaw). The types of teeth are denoted as incisors (i), canine (c), premolars (pm) and molars (m). The dental formula is presented as:

For Milk teeth in each half of upper and lower jaw:

$$\frac{2, 1, 2}{2, 1, 2} = 10 \times 2 = 20$$

For Permanent teeth in each half of upper and lower jaw:

$$\frac{2, 1, 2, 3}{2, 1, 2, 3} = 16 \times 2 = 32$$

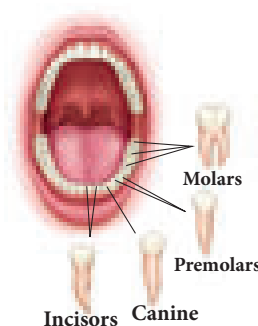

**Figure 20.2** Different kinds of teeth

#### Activity 1

Look at the pictures given below and answer the questions that follow:

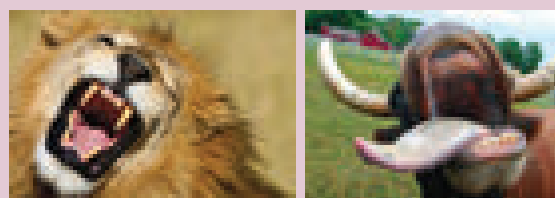

1. Are the teeth of animals similar to ours?
2. How is the shape of their teeth related to their food habit?

**Salivary glands:** Three pairs of salivary glands are present in the mouth cavity. They are: parotid glands, sublingual glands and submaxillary or submandibular glands

- a. **Parotid glands** are the largest salivary glands, which lie in the cheeks in front of the ears (in Greek Par - near ; otid - ear).

- b. **Sublingual glands** are the smallest glands and lie beneath the tongue.
- c. **Submaxillary or Submandibular glands** lie at the angles of the lower jaw.

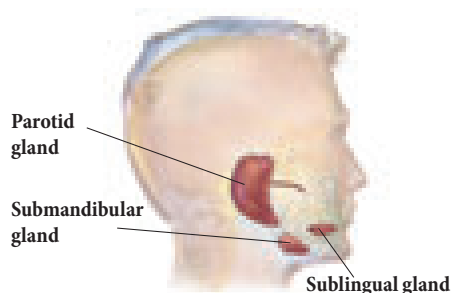

**Figure 20.3** Salivary glands

The salivary glands secrete a viscous fluid called saliva, approximately 1.5 liters per day. It digests starch by the action of the enzyme **ptyalin** (amylase) in the saliva which converts starch (polysaccharide) into maltose (disaccharide). Saliva also contains an antibacterial enzyme called **lysozyme**.

**Tongue:** The tongue is a muscular, sensory organ which helps in mixing the food with the saliva. The taste buds on the tongue help to recognize the taste of food. The masticated food in the buccal cavity becomes a bolus which is rolled by the tongue and passed through pharynx into the oesophagus by swallowing. During swallowing, the epiglottis (a muscular flap-like structure at the tip of the glottis, beginning of trachea) closes and prevents the food from entering into trachea (wind pipe).

**Pharynx:** The pharynx is a membrane lined cavity behind the nose and mouth, connecting them to the oesophagus. It serves as a pathway for the movement of food from mouth to oesophagus.

**Oesophagus:** Oesophagus or the food pipe is a muscular-membranous canal about 22 cm in length. It conducts food from pharynx to the stomach by peristalsis (wave-like movement) produced by the rhythmic contraction and relaxation of the muscular walls of alimentary canal.

**Stomach:** The stomach is a wide J-shaped muscular organ located between oesophagus and the small intestine. The gastric glands present in the inner walls of the stomach secrete gastric juice. The gastric juice is colourless, highly acidic, containing mucus, hydrochloric acid and enzymes rennin (in infants) and pepsin.

Inactive pepsinogen is converted to active **pepsin** which acts on the proteins in the ingested food. **Hydrochloric acid** kills the bacteria swallowed along with food and makes the medium acidic while the mucus protects the wall of the stomach. The action of the gastric juice and churning of food in the stomach convert the bolus into a semi-digested food called **chyme**. The chyme moves to the intestine slowly through the pylorus.

#### More to Know

- ❑ **Rennin:** Causes curdling of milk protein caesin and increases digestion of proteins.
- ❑ **Renin:** Converts angiotensinogen to angiotensin and regulate the absorption of water and  $\text{Na}^+$  from glomerular filtrate.

**Small intestine:** The small intestine is the longest part of the alimentary canal, which is a long coiled tube measuring about 5 – 7 m. It comprises three parts- duodenum, jejunum and ileum.

- a. **Duodenum** is C-shaped and receives the bile duct (from liver) and pancreatic duct (from pancreas).
- b. **Jejunum** is the middle part of the small intestine. It is a short region of the small intestine. The secretion of the small intestine is intestinal juice which contains the enzymes like **sucrase, maltase, lactase** and **lipase**.
- c. **Ileum** forms the lower part of the small intestine and opens into the large intestine. Ileum is the longest part of the small



intestine. It contains minute finger like projections called **villi** (one millimeter in length) where absorption of food takes place. They are approximately 4 million in number. Internally, each villus contains fine blood capillaries and lacteal tubes,

The small intestine serves both for digestion and absorption. It receives the bile from liver and the pancreatic juice from pancreas in the duodenum. The intestinal glands secrete the intestinal juices.



**William Beaumont**  
(1785-1853)

William Beaumont was a surgeon who was known as the 'Father of Gastric Physiology'. Based on his observations he concluded that the stomach's strong hydrochloric acid played a key role in digestion.

**Liver:** It is the largest digestive gland of the body which is reddish brown in colour. It is divided into two main lobes, right and left lobes. The right lobe is larger than the left lobe. On the under surface of the liver, gall bladder is present. The liver cells secrete **bile** which is temporarily stored in the gall bladder. Bile is released into small intestine when food enters in it. It has **bile salts** (sodium glycolate and sodium tauraglycolate) and **bile pigments** (bilirubin and biliviridin). Bile salts help in the digestion of fats by bringing about their **emulsification** (conversion of large fat droplets into small ones).

#### Functions of Liver

- Controls blood sugar and amino acid levels.
- Synthesizes foetal red blood cells.
- Produces fibrinogen and prothrombin, used for clotting of blood.
- Destroys red blood cells.
- Stores iron, copper, vitamins A and D.

- Produces heparin (an anticoagulant).
- Excretes toxic and metallic poisons.
- Detoxifies substances including drugs and alcohol.

**Pancreas:** It is a lobed, leaf shaped gland situated between the stomach and duodenum. **Pancreas** acts both as an **exocrine gland** and as an **endocrine gland**. The exocrine part of the pancreatic gland secretes pancreatic juice which contains three enzymes- lipase, trypsin and amylase which acts on fats, proteins and starch respectively. The gland's upper surface bears the **islets of Langerhans** which have endocrine cells and secrete hormones in which **α (alpha) cells** secrete **glucagon** and **β (beta) cells** secrete **insulin**.

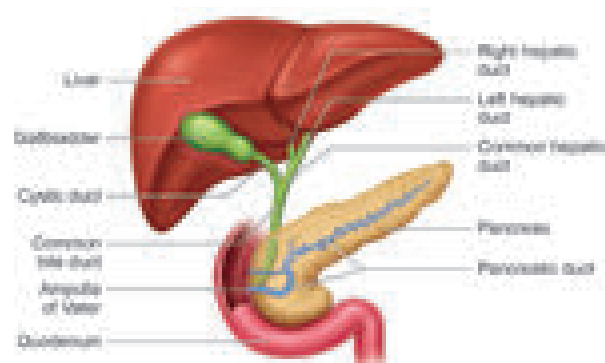

**Figure 20.4** Bile duct and Pancreatic duct opening into duodenum

The intestinal glands secrete intestinal juice called **succus entericus** which contains enzymes like maltase, lactase, sucrase and lipase which act in an alkaline medium. From the duodenum the food is slowly moved down to ileum, where the digested food gets absorbed

**a. Absorption of food:** Absorption is the process by which nutrients obtained after digestion are absorbed by villi and circulated throughout the body by blood and lymph and supplied to all body cells according to their requirements.

**b. Assimilation of food:** Assimilation means the incorporation of the absorbed food materials into the tissue cells as their internal and homogenous component. The final products of fat digestion (fatty acids and glycerol) are again converted into fats and

excess fats are stored in adipose tissue. The excess sugars are converted into a complex polysaccharide, glycogen in the liver. The amino acids are utilized to synthesize different proteins required for the body.

**DO YOU KNOW?** The small intestine is about 5 m long and is the longest part of the digestive system. The large intestine is a thicker tube, but is about 1.5 m long.

**Large intestine:** The unabsorbed and undigested food is passed into the large intestine. It extends from the ileum to the anus. It is about 1.5 meters in length. It has three parts- **caecum, colon** and **rectum**.

The caecum is a small blind pouch like structure situated at the junction of the small and large intestine. From its blind end a finger – like structure called **vermiform appendix** arises. It is a **vestigial (functionless) organ** in human beings.

The colon is much broader than ileum. It passes up the abdomen on the right (**ascending colon**), crosses to the left just below the stomach (**transverse colon**) and down on the left side (**descending colon**). The rectum is the last part which opens into the anus. It is kept closed by a ring of muscles called anal sphincter which opens when passing stools.

The undigested or unassimilated portion of the ingested food material is thrown out from the body through the anal aperture as faecal matter. This is known as **egestion** or **defaecation**.

### Activity 2

Construct a model of the human digestive system using simple materials like funnel, pipe, cellotape and clean bag. Label its parts and write which parts help in the various steps of digestion.

**Table 20.3** Chart showing the Digestive Enzymes

Digestive glands	Enzymes	Substrate (nutrient)	Products of digestion
<b>Salivary glands</b>	Ptyalin (Salivary amylase)	Starch	Maltose
<b>Gastric glands</b>	Pepsin	Proteins	Peptones
	Rennin (in infants)	Milk protein or caseinogen	Curdles milk to produce casein protein
<b>Pancreas</b>	Pancreatic amylase	Starch	Maltose
	Trypsin	Proteins and peptones	Peptides and amino acids
	Chymotrypsin	Protein	Proteoses, Peptones, Polypeptide, tri and dipeptides
	Pancreatic lipase	Emulsified fats	Fatty acids and Glycerol
<b>Intestinal glands</b>	Maltase	Maltose	Glucose and Glucose
	Lactase	Lactose	Glucose and Galactose
	Sucrase	Sucrose	Glucose and Fructose
	Lipase	Fats	Fatty acids and Glycerol

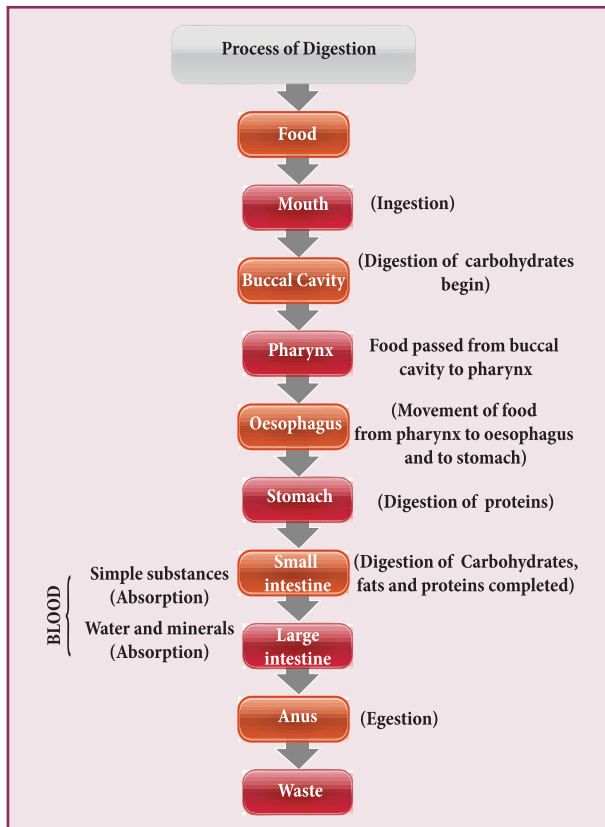

## 20.2 Human Excretory System

Metabolic activities continuously take place in living cells. All metabolic products produced by the biochemical reactions are not utilized by the body because certain nitrogenous toxic waste substances are also produced. They are called excretory products. In human beings **urea** is the major excretory product. The tissues and organs associated with the removal of waste products constitute the excretory system.

The human excretory system consists of a pair of kidney, which produce the urine, a pair of ureters which conduct the urine from kidneys to the urinary bladder, where urine is stored temporarily and urethra through which the urine is voided by bladder contractions.

If the waste products are accumulated and not eliminated, they become harmful and poisonous to the body. Hence, excretion plays an important role in maintaining the homeostatic condition of the body.

Some of the excretory organs other than kidneys are **skin** (removes small amounts of

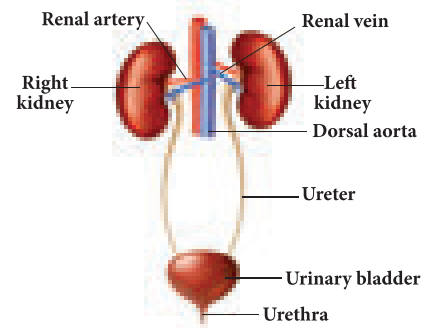

Figure 20.5 Excretory system

water, urea and salts in the form of sweat) and **lungs** (eliminate carbon-dioxide and water vapour through exhaling).

### 20.2.1 Skin

Skin is the outer most covering of the body. It stretches all over the body in the form of a layer. It accounts for 15% of an adult's human body weight. There are many structures and glands derived from the skin. It eliminates metabolic wastes through perspiration.

The human body functions normally at a temperature of about 37 °C. When it gets hot sweat glands start secreting sweat, which contains water with small amounts of other chemicals like ammonia, urea, lactic acid and salts (mainly sodium chloride). The sweat passes through the pores in the skin and gets evaporated.

### 20.2.2 Kidneys

Kidneys are bean-shaped organs reddish brown in colour. The kidneys lie on either side of the vertebral column in the abdominal cavity attached to the dorsal body wall. The right kidney is placed lower than the left kidney as the liver takes up much space on the right side. Each kidney is about 11 cm long, 5 cm wide and 3 cm thick. The kidney is covered by a layer of fibrous connective tissue, the renal capsules, adipose capsule and a fibrous membrane.

Internally the kidney consists of an outer dark region, the **cortex** and an inner lighter region, the **medulla**. Both of these regions contain **uriniferous tubules** or **nephrons**. The

medulla consists of multitubular conical masses called the medullary pyramids or renal pyramids whose bases are adjacent to cortex. On the inner concave side of each kidney, a notch called **hilum** is present through which blood vessels and nerves enter in and the urine leaves through the Ureter.

**Ureters:** Ureters are thin muscular tubes emerging out from the hilum. Urine enters the ureter from the renal pelvis and is conducted along the ureter by peristaltic movements of its walls. The ureters carry urine from kidney to urinary bladder.

**Urinary bladder:** Urinary bladder is a sac-like structure, which lies in the pelvic cavity of the abdomen. It stores urine temporarily.

**Urethra:** Urethra is a membranous tube, which conducts urine to the exterior. The urethral sphincters keep the urethra closed and opens only at the time of **micturition** (urination).

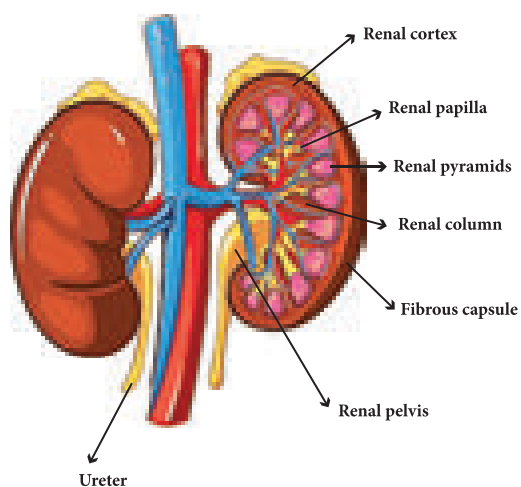

**Figure 20.6** Longitudinal section of human kidney

### Functions of kidney

1. Maintains the fluid and electrolytes balance in our body.
2. Regulates acid-base balance of blood.
3. Maintains the osmotic pressure in blood and tissues.
4. Helps to retain the important plasma constituents like glucose and amino acids.



### 20.2.3 Structure of Nephron

Each kidney consists of more than one million nephrons. **Nephrons or uriniferous tubules** are structural and functional units of the kidneys. Each nephron consists of **Renal corpuscle** or **Malpighian corpuscle** and **renal tubule**. The renal corpuscle consists of a cup-shaped structure called **Bowman's capsule** containing a bunch of capillaries called **glomerulus**. Blood enters the glomerular capillaries through **afferent** arterioles and leaves out through **efferent** arterioles. The Bowman's capsule continues as the renal tubule which consists of three regions **proximal convoluted tubule**, U-shaped hair pin loop, the **loop of Henle** and the **distal convoluted tubule**. The distal convoluted tubule opens into the **collecting tubule**. The nitrogenous wastes are drained into renal pelvis which leads to ureters and stored in the urinary bladder. Urine is expelled out through the urethra.

### 20.2.4 Mechanism of Urine Formation

The process of urine formation includes the following three stages.

- Glomerular filtration
- Tubular reabsorption
- Tubular secretion

**Glomerular filtration:** Urine formation begins with the filtration of blood through epithelial walls of the glomerulus and Bowman's capsule. The filtrate is called as the glomerular filtrate. Both essential and non-essential substances present in the blood are filtered.

**Tubular reabsorption:** The filtrate in the proximal tubule consists of essential substances such as glucose, amino acids, vitamins, sodium, potassium, bicarbonates and water that are reabsorbed into the blood by a process of **selective reabsorption**.

**Tubular secretion:** Substances such as  $H^+$  or  $K^+$  ions are secreted into the tubule. This tubular filtrate is finally known as urine, which is **hypertonic** in man. Finally the urine passes

into collecting ducts to the pelvis and through the ureter into the urinary bladder. When the urinary bladder is full the urine is expelled out through the urethra. This process is called **micturition**. A healthy person excretes one to two litres of urine per day.

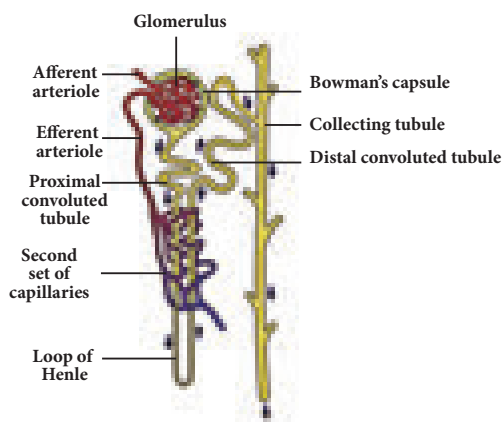

**Figure 20.7** Structure of Nephron



Two healthy kidneys contain a total of about 2 million nephrons, which filter about 170-180 litres of blood per day. The kidneys reabsorb and redistribute 99% of the blood volume and only 1% of the blood filtered becomes urine.

**Dialysis or Artificial kidney :** When kidneys lose their filtering efficiency, excessive amount of fluid and toxic waste accumulate in the body. This condition is known as **kidney (renal) failure**. For this, an artificial kidney is used to filter the blood of the patient. The patient is said to be put on dialysis and the process of purifying blood by an artificial kidney is called **haemodialysis**. When renal failure cannot be treated by drug or dialysis, the patients are advised for kidney transplantation.



**First kidney transplant**

In 1954, Joseph E. Murray and his colleagues at Peter Bent Brigham Hospital in Boston, USA performed first successful kidney transplant between Ronald and Richard Herrick who were identical twins. The recipient Richard Herrick died after 8 years of transplantation

**Route of urine flow**

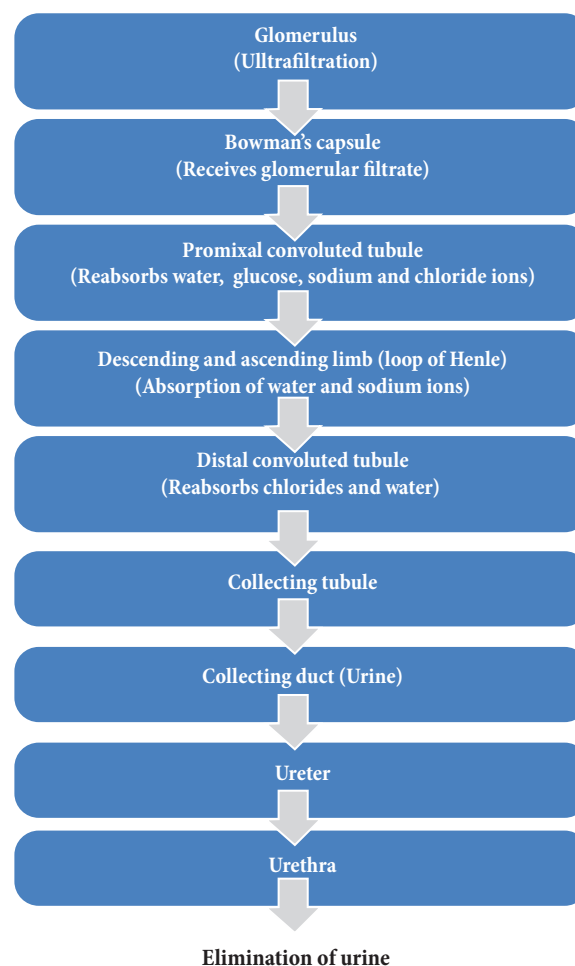

Elimination of urine

**20.3 Human Reproductive System**

The capacity to reproduce is one of the most important characteristics of living beings. There is a distinct sexual dimorphism in human beings i.e., males are visibly different from females in physical build up, external genital organs and secondary sexual characters.

The reproductive systems of male and female consist of many organs which are distinguished as primary and secondary sex organs. The primary sex organs are gonads, which produce gametes (sex cells) and secrete sex hormones. The secondary sex organs include the genital ducts and glands which help in the transportation of gametes and enable the reproductive process.

The reproductive organs become functional after attaining sexual maturity. In males, sexual

maturity is attained at the age of 13-14 years. In females, it is attained at the age of 11-13 years. This age is known as the age of puberty. During sexual maturity, hormonal changes take place in males and females and secondary sexual characters are developed under the influence of these hormones.

### 20.3.1 Male Reproductive System

Human male reproductive system consists of testes (primary sex organs), scrotum, vas deferens, urethra, penis and accessory glands.

**Testes:** A pair of testes lies outside the abdominal cavity of the male. These testes are the male gonads, which produce male gametes (**sperms**) and male sex hormone (**Testosterone**). Along the inner side of each testis lies a mass of coiled tubules called **epididymis**. The **Sertoli cells** of the testes provide nourishment to the developing sperms.

**Scrotum:** The scrotum is a loose pouch-like sac of skin which is divided internally into right and left **scrotal sacs** by muscular partition. The two testes lie in the respective scrotal sacs. It also contains many nerves and blood vessels. The **scrotum** acts as a **thermoregulator organ** and provides an optimum temperature for the formation of sperms. The sperms develop at a temperature of 1-3°C lower than the normal body temperature.

**Vas deferens:** It is a straight tube which carries the sperms to the **seminal vesicles**. The sperms are stored in the seminal plasma of seminal vesicle, which is rich in fructose, calcium and enzymes. Fructose is a source of energy for the sperm. The **vas deferens** along with seminal vesicles opens into ejaculatory duct which expels the sperm and its secretions from seminal vesicles into the urethra.

**Urethra:** It is contained inside the penis and conveys the sperms from the vas deferens which pass through the urethral opening. The accessory glands associated with the male reproductive system consist of seminal vesicles, prostate gland and Cowper's glands. The secretions of these glands form seminal fluid and mixes with the sperm to form

semen. This fluid provides nutrition and helps in the transport of sperms.

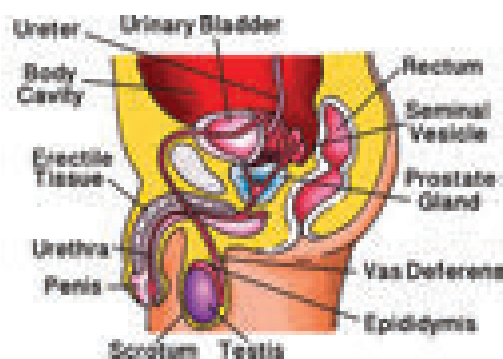

Figure 20.8 Male reproductive system



The sperm is the smallest cell in the male body. A normal male produces more than 500 billion sperm cells in his life time. The process of formation of sperms is known as spermatogenesis.

### 20.3.2 Female Reproductive System

The female reproductive system consists of ovaries (primary sex organs), oviducts, uterus and vagina.

**Ovaries:** A pair of almond-shaped ovaries is located in the lower part of abdominal cavity near the kidneys in female. The ovaries are the female gonads, which produce female gametes (**eggs or ova**) and secrete female sex hormones (**Oestrogen and Progesterone**). A mature ovary contains a large number of ova in different stages of development.

**Fallopian tubes (Oviducts):** These are paired tubes originating from uterus, one on either side. The terminal part of **fallopian tube** is funnel-shaped with finger-like projections called **fimbriae** lying near the ovary. The fimbriae pick up the ovum released from ovary and push it into the fallopian tube.

**Uterus:** Uterus is a pear-shaped muscular, hollow structure present in the pelvic cavity. It lies between urinary bladder and rectum.

Development of foetus occurs inside the uterus. The narrower lower part of uterus is called **cervix**, which leads into vagina.

**Vagina:** The uterus narrows down into a hollow muscular tube called vagina. It connects cervix and the external genitalia. It receives the sperms, acts as birth canal during child birth (**parturition**).

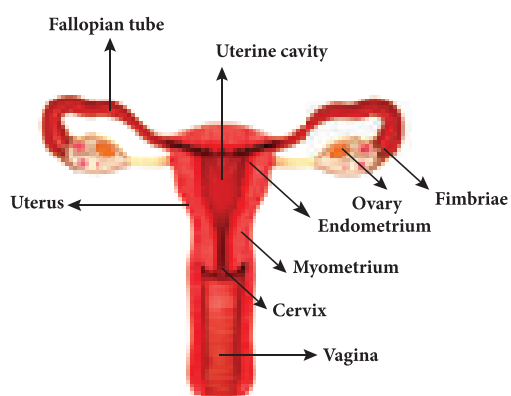

**Figure 20.9** Female reproductive system

### Points to Remember

- ❖ All the organ systems work together in coordination to maintain the body in a homeostatic condition of an organism.
- ❖ Alimentary canal consists of mouth, buccal cavity, pharynx, oesophagus, stomach, small intestine (consisting of duodenum, jejunum and ileum), large intestine (consisting of caecum, colon and rectum) and anus.
- ❖ The five stages of nutrition process include ingestion, digestion, absorption, assimilation and egestion.
- ❖ The small intestine serves both for digestion and absorption.
- ❖ The human excretory system consists of a pair of kidney, which produce the urine.
- ❖ The process of urine formation includes the following three stages: Glomerular filtration, tubular reabsorption and tubular secretion.
- ❖ The reproductive organ of male is testis and female is ovary which are distinguished as primary sex organs.

### More to Know

An ovum is the largest human cell. The process of formation of ova is known as **oogenesis**.

## A-Z GLOSSARY

<b>Emulsification</b>	Conversion of large fat droplets into smaller ones.
<b>Enzymes</b>	Substances produced by living organisms which acts as a catalyst to bring about specific biochemical reactions.
<b>Homeostasis</b>	Tendency of the body to seek and maintain a balance condition or equilibrium within its internal environment.
<b>Mastication (Chewing)</b>	Process by which food is crushed and ground by teeth.
<b>Metabolism</b>	Sum total of all chemical and energy changes taking place in an organism.
<b>Osmoregulation</b>	Maintenance of constant osmotic pressure in the fluids of an organism by the control of water and salt concentration.
<b>Regurgitation</b>	Act of bringing swallowed food back into the mouth.
<b>Toxic substance</b>	Substances that can be poisonous or cause health effects to living organisms.



## TEXTBOOK EXERCISES



### I. Choose the correct answer.

- Which of the following is not a salivary gland?
  - Sublingual
  - Lachrymal
  - Submaxillary
  - Parotid
- Stomach of human beings mainly digests \_\_\_\_\_
  - carbohydrates
  - proteins
  - fat
  - sucrose
- To prevent the entry of food into the trachea, the opening is guarded by \_\_\_\_\_
  - epiglottis
  - glottis
  - hard palate
  - soft palate
- Bile helps in the digestion of \_\_\_\_\_
  - proteins
  - sugar
  - fats
  - carbohydrates
- The structural and functional unit of the kidney is \_\_\_\_\_
  - villi
  - liver
  - nephron
  - ureter
- Which one of the following substance is not a constituent of sweat?
  - Urea
  - Protein
  - Water
  - Salt
- The common passage meant for transporting urine and sperms in male is \_\_\_\_\_
  - ureter
  - urethra
  - vas deferens
  - scrotum
- Which of the following is not a part of female reproductive system?
  - Ovary
  - Uterus
  - Testes
  - Fallopian tube

### II. Fill in the blanks.

- The opening of the stomach into the intestine is called \_\_\_\_\_.

- The muscular and sensory organ which helps in mixing the food with saliva is \_\_\_\_\_.
- Bile, secreted by liver is stored temporarily in \_\_\_\_\_.
- The longest part of alimentary canal is \_\_\_\_\_.
- The human body functions normally at a temperature of about \_\_\_\_\_.
- The largest cell in the human body of a female is \_\_\_\_\_.

### III. State whether true or false. If false, correct the statement.

- Nitric acid in the stomach kills microorganisms in the food.
- During digestion, proteins are broken down into amino acids.
- Glomerular filtrate consists of many substances like amino acids, vitamins, hormones, salts, glucose and other essential substances.

### IV. Match the following.

Organ	Elimination
Skin	a. Urine
Lungs	b. Sweat
Intestine	c. Carbon dioxide
Kidneys	d. Undigested food

### V. Differentiate the following.

- Excretion and Secretion
- Absorption and Assimilation
- Ingestion and Egestion
- Diphyodont and Heterodont
- Incisors and Canines



## VI. Answer briefly.

- How is the small intestine designed to absorb digested food?
- Why do we sweat?
- Mention any two vital functions of human kidney.
- What is micturition?
- Name the types of teeth present in an adult human being. Mention the functions of each.
- Explain the structure of nephron.

## VII. Answer in detail.

- Describe the alimentary canal of man
- Explain the structure of kidney and the steps involved in the formation of urine

## VIII. Assertion and reason type questions.

Mark the correct answer as:

- If both Assertion and Reason are true and Reason is the correct explanation of Assertion.
  - If both Assertion and Reason are true but Reason is not the correct explanation of Assertion.
  - If Assertion is true but Reason is false.
  - If both Assertion and Reason are false.
- Assertion: Urea is excreted out through the kidneys.  
Reason: Urea is a toxic substance.
  - Assertion: In both the sexes gonads perform dual function.  
Reason: Gonads are also called primary sex organs.

## IX. Higher Order Thinking Skills

- If pepsin is lacking in gastric juice, then which event in the stomach will be affected?
  - digestion of starch into sugars.
  - breaking of proteins into peptides.
  - digestion of nucleic acids.
  - breaking of fats into glycerol and fatty acids.
- Name the blood vessel that (a) enter malphigian capsule and (b) leaves malphigian capsule.
- Why do you think that urine analysis is an important part of medical diagnosis?
- Why your doctor advises you to drink plenty of water?
- Can you guess why there are sweat glands on the palm of our hands and the soles of our feet?

## X. Match the parts of the given figure with the correct option.

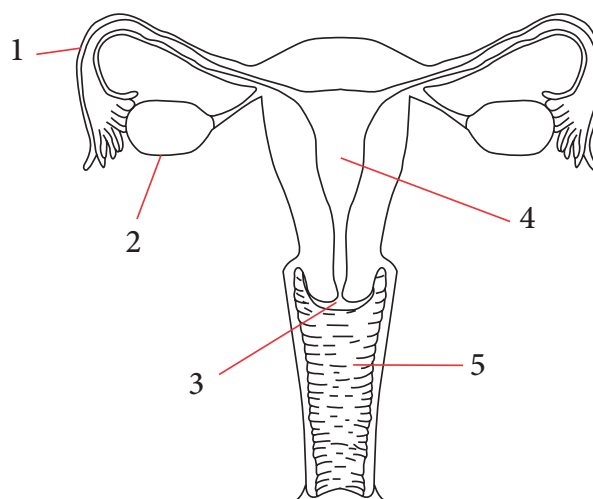

1	2	3	4	5
a. Fallopian tube	Oviduct	Uterus	Cervix	Vagina
b. Oviduct	Cervix	Vagina	Ovary	Vas deferens
c. Ovary	Oviduct	Uterus	Vagina	Cervix
d. Fallopian tube	Ovary	Cervix	Uterus	Vagina

## REFERENCE BOOKS

Verma P.S and Agarwal, V.K. Animal Physiology, S. Chand and Company, New Delhi

## INTERNET RESOURCES

<https://www.britannica.com/science/human-digestive-system>

<https://biologydictionary.net/excretory-system/>

<https://www.britannica.com/science/human-reproductive-system>

### Concept Map

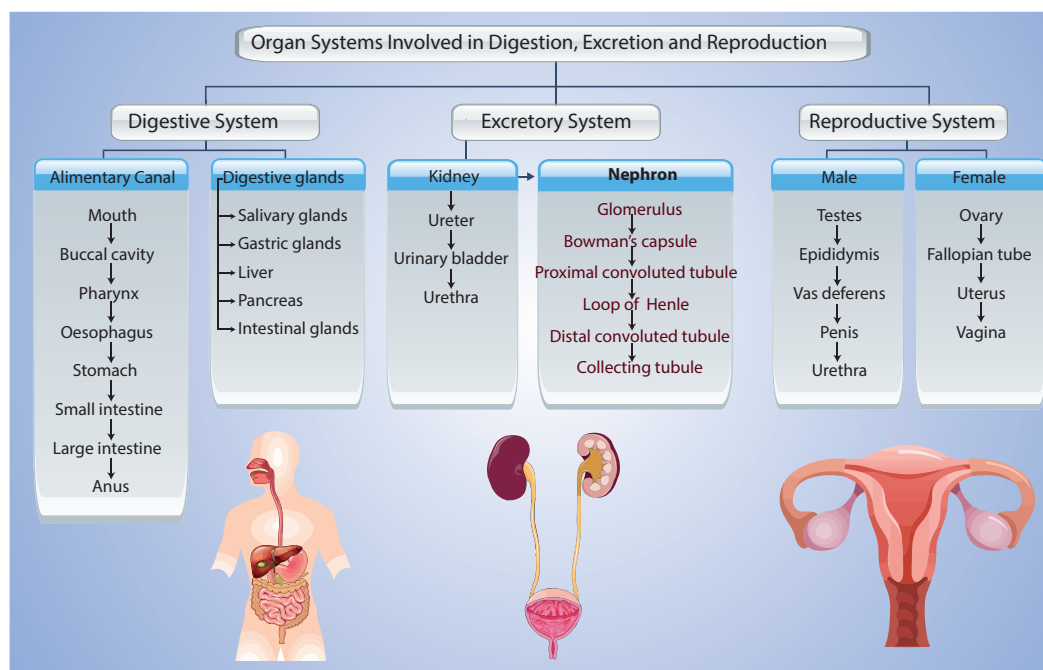

### ICT CORNER

## Human digestive system

This activity enables to explore the functions of every part in the digestive system

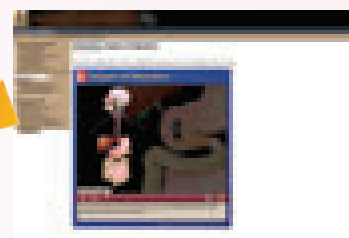

### Steps

- Type the URL link given below in the browser or scan the QR code. You can view “the digestive system”.
- Click the **go to interactive mode** to explore the functions of each part you want to learn.
- Every part and its function can be learnt by clicking that particular part that we want to learn.
- Also you can see the process of digestion by clicking **go to animation mode**.

### Browse in the link:

URL: [http://higher.ed.mheducation.com/sites/0072495855/student\\_view0/chapter26/animation\\_\\_organs\\_of\\_digestion.html](http://higher.ed.mheducation.com/sites/0072495855/student_view0/chapter26/animation__organs_of_digestion.html)



B567\_9\_SCI\_EM\_T3

# UNIT 21

## NUTRITION AND HEALTH

### Learning Objectives



After completing this lesson, students will be able to:

- understand the classification of nutrients.
- list the sources, functions and deficiency disorders of vitamins and minerals.
- gain knowledge about different methods of food preservation.
- identify the adulterants in food.
- explain the role of different food quality certifying agents of our country.

### Introduction

Food is the basic necessity of life. Food is defined as any substance of either plant or animal origin consumed to provide nutritional support for an organism. It contains essential nutrients that provide energy, helps in normal growth and development, repair the worn out tissues and protect the body from diseases.

Food contamination with microorganisms is a major source of illness either in the form of infections or poisoning. Food safety is becoming a major concern these days. Adulteration of foodstuffs is commonly practiced in India by traders. Food is contaminated or adulterated from production to consumption for financial gain. The normal physiological functions of a consumer are affected due to either addition of a deleterious substance or the removal of a vital component. Food laws have come into existence to maintain the quality of food produced in our country. Let us study about them in detail.

### 21.1 Classes of Nutrients

Nutrients are classified into the following major groups as given below.

- Carbohydrates
- Proteins
- Fats
- Vitamins
- Minerals

#### 21.1.1 Carbohydrates

Carbohydrates are organic compounds composed of carbon, hydrogen and oxygen. Carbohydrate is an essential nutrient which provides the chief source of energy to the body. Glucose, sucrose, lactose, starch, cellulose are examples for carbohydrates.

Carbohydrates are classified as monosaccharide (Glucose), disaccharide (Sucrose) and polysaccharide (Cellulose). The classification is based on the number of sugar molecules present in each group.

### 21.1.2 Proteins

Proteins are the essential nutrients and also the building blocks of the body. They are essential for growth and repair of body cells and tissues. Proteins are made of amino acids.

Essential amino acids are those that cannot be biosynthesized by the body and must be obtained from the diet. The nine essential amino acids are phenylalanine, valine, threonine, tryptophan, methionine, leucine, isoleucine, lysine and histidine.

### 21.1.3 Fats

Fat in the diet provides energy. They maintain cell structures and are involved in metabolic functions.

Essential fatty acids cannot be synthesized in the body and are provided through diet. Essential fatty acids required in human nutrition are omega fatty acids.

### 21.1.4 Vitamins

Vitamins are the vital nutrients, required in minute quantities to perform specific physiological and biochemical functions.



#### More to Know

Dr. Funk introduced the term vitamin. Vitamin A was given the first letter of the alphabet, as it was the first vitamin discovered.



Human skin can synthesize Vitamin D when exposed to sunlight (especially early morning). When the sun rays fall on the skin dehydrocholesterol is converted into Vitamin D. Hence, Vitamin D is called as **Sunshine vitamin**. Vitamin D improves bone strength by helping body to absorb calcium.

### 21.1.5 Minerals

Minerals are inorganic substances required as an essential nutrient by organisms to perform various biological functions necessary for life. They are the constituents of teeth, bones, tissues, blood, muscle and nerve cells.

The **macrominerals** required by the human body are calcium, phosphorus, potassium, sodium and magnesium. The **microminerals** required by the human body also called **trace elements** are sulfur, iron, chlorine, cobalt, copper, zinc, manganese, molybdenum, iodine and selenium.

## 21.2 Protein Energy Malnutrition (PEM)

Absence of certain nutrients in our daily diet over a long period of time leads to deficiency diseases. This condition is referred as Malnutrition. Deficiency of proteins and energy leads to severe conditions like: Kwashiorkar and Marasmus.

Table 21.1 Dietary sources of major foodstuffs

Major food stuffs	Dietary sources	Daily requirements (grams)
Carbohydrates	Honey, sugarcane, fruits, whole grains, starchy vegetables, rice	150-200
Proteins	Legumes, pulses, nuts, soya bean, green leafy vegetables, fish, poultry products, egg, milk and dairy products	40
Fats	Egg yolk, saturated oil, meat	35

**Table 21.2** Vitamins-Dietary sources, Deficiency disorders and Symptoms

Vitamins	Sources	Deficiency disorders	Symptoms
<b>Fat Soluble Vitamins</b>			
<b>Vitamin A</b> (Retinol)	Carrot, papaya, leafy vegetables, fish liver oil, egg yolk, liver, dairy products	Xerophthalmia Nyctalopia (Night blindness)	Dryness of Cornea Unable to see in the night (dim light) Scaly skin
<b>Vitamin D</b> (Calciferol)	Egg, liver, dairy products, Fish, synthesized by the skin in sunlight	Rickets (in children)	Bow legs, defective ribs, development of pigeon chest
<b>Vitamin E</b> (Tocopherol)	Whole wheat, meat, vegetable oil, milk	Sterility in rats, Reproductive abnormalities	Sterility
<b>Vitamin K</b> (Derivative of Quinone)	Leafy vegetables, soyabeans, milk	Blood clotting is prevented	Excessive bleeding due to delayed blood clotting
<b>Water Soluble Vitamins</b>			
<b>Vitamin B1</b> (Thiamine)	Whole grains, yeast, eggs, liver, sprouted pulses	Beriberi	Degenerative changes in the nerves, muscles become weak, paralysis
<b>Vitamin B2</b> (Riboflavin)	Milk, eggs, liver, green vegetables, whole grains	Ariboflavinosis (Cheilosis)	Irritation in eyes, dry skin, inflammation of lips, fissures in the corners of the mouth
<b>Vitamin B3</b> (Niacin)	Milk, eggs, liver, lean meat, ground nuts, bran	Pellagra	Inflammation of skin, loss of memory, diarrhoea
<b>Vitamin B6</b> (Pyridoxine)	Meat, fish, eggs, germs of grains and cereals, rice polishings	Dermatitis	Scaly skin, nervous disorders
<b>Vitamin B12</b> (Cyanocobalamine)	Milk, meat, liver, pulses, cereals, fish	Pernicious anaemia	Decrease in red blood cell production, degeneration of spinal cord
<b>Vitamin C</b> (Ascorbic acid)	Leafy vegetables, sprouts, citrus fruits like goose berry (Amala), lemon, orange	Scurvy	Swollen and bleeding gums, delay in healing of wounds, teeth and bones malformed

**Table 21.3** Minerals - Dietary sources, Functions and Deficiency disorders

Minerals	Sources	Functions	Deficiency disorders
<b>Macronutrients</b>			
<b>Calcium</b>	Dairy products, beans, cabbage, eggs, fish	Constituent of bones and enamel of teeth, clotting of blood and controls muscle contraction.	Bone deformities, poor skeletal growth, osteoporosis in adults.
<b>Sodium</b>	Common salt	Maintains fluid balance and involved in neurotransmission.	Muscular cramps, nerve impulses do not get transmitted.
<b>Potassium</b>	Banana, sweet potato, nuts, whole grains, citrus fruits	Regulates nerve and muscle activity.	Muscular fatigue, nerve impulses do not get transmitted.
<b>Micronutrients</b>			
<b>Iron</b>	Spinach, dates, greens, broccoli, whole cereals, nuts, fish, liver	Important component of haemoglobin.	Anaemia
<b>Iodine</b>	Milk, Seafood, Iodised salt	Formation of thyroid hormones.	Goitre

**Kwashiorkar:** It is a condition of severe protein deficiency. It affects children between 1-5 years of age, whose diet mainly consists of carbohydrates but lack in proteins.

**Marasmus:** It usually affects infants below the age of one year when the diet is poor in carbohydrates, fats and proteins.



**Kwashiorkar**

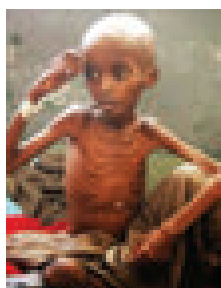

**Marasmus**

**Figure 21.1** Malnutrition

## 21.3 Food Hygiene

Food spoilage is an undesirable change in the normal state of food and is not suitable for human consumption. Poor personal hygiene may allow pathogenic microorganisms to cause food spoilage. Signs of food spoilage include a changes in appearance, colour, texture, odour

and taste. Factors responsible for Food Spoilage are given below.

**Internal factors:** It includes enzymatic activities and moisture content of the food.

**External factors:** It includes adulterants in food, contaminated utensils and equipment, unhygienic cooking area and lack of storage facilities.

## 21.4 Food Preservation

Food preservation is the process of prevention of food from decay or spoilage, by storing in a condition fit for future use. Food is preserved to:

- increase the shelf life of food
- retain the colour, texture, flavour and nutritive value
- increase food supply
- decrease wastage of food

### 21.4.1 Methods of Food Preservation

The various method of food preservation are explained below.



**Drying:** Drying is the process of preservation of food by removal of water/moisture content in the food. It can be done either by sun-drying, (e.g. cereals, fish) or vacuum drying (e.g. milk powder, cheese powder) or hot air drying (e.g. grapes, dry fruits, potato flakes). Drying inhibits the growth of microorganism such as bacteria, yeasts and moulds.

**Smoking:** In this process, food products like meat and fish are exposed to smoke. The drying action of the smoke tends to preserve the food.

**Irradiation:** Food irradiation is the process of exposing food to optimum levels of ionizing radiations like x-rays, gamma rays or UV rays to kill harmful bacteria and pests and to preserve its freshness.

**Cold storage:** It is a process of storing the perishable foods such as vegetables, fruits and fruit products, milk and milk products etc. at low temperature. Preserving the food products at low temperature slows down the biological and chemical reactions and prevents its spoilage.

**Freezing:** Freezing is one of the widely used methods of food preservation. This process involves storing the food below 0°C at which microorganisms cannot grow, chemical reactions are reduced and metabolic reactions are also delayed.

**Pasteurization:** Pasteurization is a process of heat treatment of liquid food products. e.g. For preservation of milk and beverages. This process also involves boiling of milk to a temperature of 63°C for about 30 minutes and suddenly cooling to destroy the microbes present in the milk.



Bananas are best stored at room temperature. When it is kept in a refrigerator, the enzyme responsible for ripening becomes inactive. In addition, the enzyme responsible for browning and cell damage becomes more active thereby causing the skin colour change from yellow to dark brown.

**Canning:** In this method of food preservation, most vegetables, fruits, meat and dairy products, fruit juices and some ready-to-eat foods are processed and stored in a clean, steamed air tight containers under pressure and then sealed. It is then subjected to high temperature and cooled to destroy all microbes.

### 21.4.2 Addition of Preservatives

Food can be preserved by adding natural and synthetic preservatives.

#### A. Natural preservatives

Some naturally available materials like salt, sugar and oil are used as food preservatives.

**Addition of salt:** It is one of the oldest methods of preserving food. Addition of salt removes the moisture content in the food by the process of osmosis. This prevents the growth of bacteria and reduces the activity of microbial enzymes. Meat, fish, gooseberry, lemon and raw mangoes are preserved by salting. Salt is also used as a preservative in pickles, canned foods etc.

**Addition of sugar:** Sugar/Honey is added as a preservative to increase the shelf life of fruits and fruit products like jams, jellies, squash, etc. The hygroscopic nature of sugar/honey helps in reducing the water content of food and also minimizing the process of oxidation in fruits.

**Addition of oil:** Addition of oil in pickles prevents the contact of air with food. Hence microorganisms cannot grow and spoil the food.

#### B. Synthetic preservatives

Synthetic food preservatives like sodium benzoate, citric acid, vinegar, sodium meta bisulphate and potassium bisulphate are added to food products like sauces, jams, jellies, packed foods and ready-to-eat foods. These preservatives delay the microbial growth and keep the food safe for long duration.

### More to Know

October 16<sup>th</sup> is World Food Day. It emphasizes on food safety and avoiding food wastage.

## 21.5 Food Adulteration

Adulteration is defined as the addition or subtraction of any substance to or from food, so that the natural composition and the quality of food substance is affected. **Adulterant** is any material which is used for the purpose of adulteration.

Some of the commonly adulterated foods are milk and milk products, cereals, pulses, coffee powder, tea powder, turmeric powder, saffron, confectionary, non-alcoholic beverages, spices, edible oils, meat, poultry products etc. The adulterants in food can be classified in three categories:

1. Natural adulterants
2. Incidental/unintentionally added adulterants
3. Intentionally added adulterants

### 1. Natural adulterants

Natural adulterants are those chemicals or organic compounds that are naturally present in food. e.g. toxic substances in certain poisonous mushrooms, Prussic acid in seeds of apples and cherry, marine toxins, fish oil poisoning, environmental contaminants

### 2. Incidental/unintentionally added adulterants

These types of adulterants are added unknowingly due to ignorance or carelessness during food handling and packaging. It includes:

- a. Pesticide residues
- b. Droppings of rodents, insects, rodent bites and larva in food during its storage
- c. Microbial contamination due to the presence of pathogens like *Escherichia coli*, *Salmonella* in fruits, vegetables, ready-to-eat meat and poultry products

### 3. Intentionally added adulterants

These adulterants are added intentionally for financial gain and have serious impact on the health of the consumers. These types of adulterants include:

- a. Additives and preservatives like vinegar, citric acid, sodium bicarbonate (baking soda), hydrogen peroxide in milk, modified food starch, food flavours, synthetic preservatives and artificial sweeteners.
- b. Chemicals like calcium carbide to ripen bananas and mangoes.
- c. Non certified food colours containing chemicals like metallic lead are used to give colours to vegetables like green leafy vegetables, bitter gourd, green peas etc. These colours are added to give a fresh look to the vegetables.

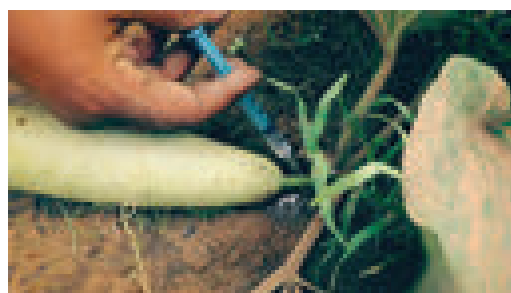

- d. Edible synthetic wax like shellac or carnauba wax is coated on fruits like apple, pear to give a shining appearance.

### 21.5.1 Health Effects of Adulterated Foods

Consumption of these adulterated foods may lead to serious health effects like fever, diarrhoea, nausea, vomiting, gastrointestinal disorders, asthma, allergy, neurological disorder, skin allergies, immune suppression, kidney and liver failure, colon cancer and even birth defects.

## 21.6 Food Quality Control

The government always ensures that pure and safe food is made available to the consumers. In 1954, the Indian Government enacted the Food Law known as Prevention of Food Adulteration Act and the Prevention of Food Adulteration Rules in 1955 with the objective of ensuring pure and wholesome food to the consumers and protect them from fraudulent trade practices.



Minimum standards of quality for food and strict hygienic conditions for its sale are clearly outlined in the Act.

**DO YOU KNOW?** A slogan **From farm to plate, make food safe** was raised on World Health Day (7<sup>th</sup> April 2015) to promote and improve food safety.

- Distributing food grains throughout the country.
- Maintaining satisfactory levels of operational and buffer stock of food grains to ensure national security.
- Regulate the market price to provide food grains to consumers at reliable price.

### 21.6.1 Food Quality Control Agencies

ISI, AGMARK, FPO, FCI and other health departments enforce minimum standards for the consumer products. **FCI (Food Corporation of India)** was set up in the year 1965 with the following objectives:





- Effective price support operations for safeguarding the interest of farmers.



#### Activity 1

Let each of the student bring any food packet (jam, juice, pickle, bread, biscuit, etc). Note down the details like name of the product, manufacturer's details, contents/ingredients, net weight, Maximum Retail Price (MRP), date of manufacture, date of expiry/usage from the date of manufacture and standardized marks (ISI, AGMARK or FPO) printed on the label for each of the item. What is the aim of such practice?

### Food Control Agencies- Their Standardized Mark and Role in Food Safety

	ISI - (Indian Standards Institution) known as Bureau of Indian Standard (BIS)	Certifies industrial products like electrical appliances like switches, wiring cables, water heater, electric motor, kitchen appliances etc.
	AGMARK - (Agricultural Marking)	Certifies agricultural and livestock products like cereals, essential oils, pulses, honey, butter etc.
	FPO - (Fruit Process Order)	Certifies the fruit products like juice, jams, sauce, canned fruits and vegetables, pickles etc.
	Food Safety and Standards Authority of India	Responsible for protecting and promoting the public health through regulation and supervision of food safety.

#### Activity 2

##### Some simple techniques used to detect adulterants at home

1. Milk: Place a drop of milk on a slanting polished surface. Pure milk flows slowly leaving a trail behind while the milk adulterated with water will flow fast without leaving a trail.

- Honey: Dip a cotton wick in honey and light it with a match stick. Pure honey burns while adulterated honey with sugar solution gives a cracking sound.
- Sugar: Dissolve sugar in water. If chalk powder is added as an adulterant, it will settle down.
- Coffee powder: Sprinkle a few pinches of coffee powder in a glass of water. Coffee powder floats. If it is adulterated with tamarind powder it settles down.
- Food grains: They have visible adulterants like marble, sand grit, stones, etc. These are removed by sorting, hand picking, washing etc.

### Points to Remember

- ❖ Food is necessary for normal growth and development of living organisms.
- ❖ Prolonged deficiency of certain nutrients cause deficiency diseases leading to malnutrition.
- ❖ Drying, smoking, irradiation, refrigeration, freezing, pasteurization and canning are some of the methods of food preservation.
- ❖ Adulterants are undesirable substances added to the food against the Food Safety Standards.
- ❖ Prevention of Food Adulteration Act, 1954 laid down the minimum standards for consumer products.

### A-Z GLOSSARY

<b>Fatigue</b>	Extreme tiredness due to mental or physical illness.
<b>Hygroscopic</b>	The property of absorbing moisture from the air.
<b>Muscular cramps</b>	Sudden and involuntary contractions of one or more muscles.
<b>Nutrients</b>	Substance that provide nourishment for normal growth and development.
<b>Nerve impulse</b>	Electric signals that travels along a nerve fibre.
<b>Nourishment</b>	Food that you need to grow and stay healthy.
<b>Osteoporosis</b>	A diseases which weakens the bones and makes it brittle.
<b>Paralysis</b>	Loss of muscle function in any part of our body which can be either temporary or permanent.
<b>Shelf life</b>	Time for which a food can be kept fresh.
<b>Toxins</b>	Any poisonous substance produced by bacteria, animals or plants.



### TEXT BOOK EXERCISES



#### I. Choose the correct answer.

- The nutrient required in trace amounts to accomplish various body functions is \_\_\_\_\_  
 a) carbohydrate      b) protein  
 c) vitamin              d) fat
- The physician who discovered that scurvy can be cured by ingestion of citrus fruits is \_\_\_\_\_  
 a) James Lind      b) Louis Pasteur  
 c) Charles Darwin      d) Isaac Newton

3. The sprouting of onion and potatoes can be delayed by the process of \_\_\_\_\_  
 a) freezing                      b) irradiation  
 c) salting                        d) canning
4. Food and Adulteration Act was enforced by Government of India in the year \_\_\_\_\_  
 a) 1964                          b) 1954  
 c) 1950                          d) 1963
5. An internal factor responsible for spoilage of food is \_\_\_\_\_  
 a) wax coating  
 b) contaminated utensils  
 c) moisture content in food  
 d) synthetic preservatives

### II. Fill in the blanks.

1. Deficiency diseases can be prevented by taking \_\_\_\_\_ diet.
2. The process of affecting the natural composition and the quality of food substance is known as \_\_\_\_\_
3. Vitamin D is called as \_\_\_\_\_ vitamin as it can be synthesised by the body from the rays of sunlight.
4. Dehydration is based on the principle of removal of \_\_\_\_\_.
5. Food should not be purchased beyond the date of \_\_\_\_\_
6. AGMARK is used to certify \_\_\_\_\_ and \_\_\_\_\_ products in India.

### III. State whether true or false. If false, correct the statement.

1. Iron is required for the proper functioning of thyroid gland.
2. Vitamins are required in large quantities for normal functioning of the body -

3. Vitamin C is a water soluble vitamin
4. Lack of adequate fats in diet may result in low body weight
5. ISI mark is mandatory to certify agricultural products.

### IV. Match the following.

#### Column A

1. Calcium
2. Sodium
3. Potassium
4. Iron
5. Iodine

#### Column B

- a. Muscular fatigue
- b. Anaemia
- c. Osteoporosis
- d. Goitre
- e. Muscular cramps

### V. Fill in the blanks with suitable answers.

Vitamins	Dietary Source	Deficiency Disease
Calciferol		Rickets
	Papaya	Night blindness
Ascorbic acid		
	Whole grains	Beriberi

### VI. Give abbreviations for the following.

- i. ISI \_\_\_\_\_
- ii. FPO \_\_\_\_\_
- iii. AGMARK \_\_\_\_\_
- iv. FCI \_\_\_\_\_
- v. FSSAI \_\_\_\_\_

### VII. Assertion and reason type questions.

Direction: In the following question, a statement of a Assertion is given and a corresponding Reason is given just below it. Of the statements given below, mark the correct answer as:

- If both Assertion and Reason are true and the Reason is the correct explanation of Assertion
- If both Assertion and Reason are true but Reason is not the correct explanation of Assertion
- If Assertion is true but Reason is false
- If both Assertion and Reason is false

1. **Assertion:** Haemoglobin contains iron.

**Reason:** Iron deficiency leads to anaemia

2. **Assertion:** AGMARK is a quality control agency

**Reason:** ISI is a symbol of quality

### VIII. Give reasons for the following statements.

- Salt is added as a preservative in pickles \_\_\_\_\_
- We should not eat food items beyond the expiry date \_\_\_\_\_
- Deficiency of calcium in diet leads to poor skeletal growth \_\_\_\_\_

### IX. Answer briefly.

- Differentiate
  - Kwashiorkar from Marasmus
  - Macronutrients from Micronutrients
- Why salt is used as preservative in food?
- What is an adulterant?
- Name any two naturally occurring toxic substances in food.
- What factors are required for the absorption of Vitamin D from the food by the body?
- Write any one function of the following minerals

- Calcium
- Sodium
- Iron
- Iodine

- Explain any two methods of food preservation.
- What are the effects of consuming adulterated food?

### X. Answer in detail.

- How are vitamins useful to us? Tabulate the sources, deficiency diseases and symptoms of fat soluble vitamins
- Explain the role of food control agencies in India.

### XI. Higher Order Thinking Skills.

- Look at the picture and answer the question that follows

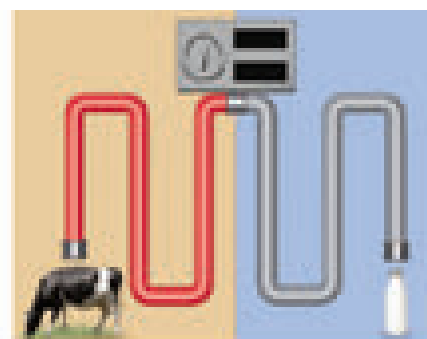

- Name the process involved in the given picture.
  - Which dairy food is preserved by this process?
  - What is the temperature required for the above process?
- The doctor advises an adolescent girl who is suffering from anaemia to include more of leafy vegetables and dates in her diet. Why so
  - Sanjana wants to buy a jam bottle in a grocery shop. What are the things she should observe on the label before purchasing it?

## REFERENCE BOOKS

1. Swaminathan M 1995: "Food & Nutrition", The Bangalore Printing & publishing co ltd., Vol I, Second Edition, Bangalore.
2. Srilakshmi 1997: "Food Science", New Age International (P) Ltd, Publishers, Pune.
3. Mudambi .R. Sumathi and Rajagpal M.V 1983, "Foods & Nutrition", Willey Eastern Ltd, Second Edition, New Delhi.
4. Shubhangini A. Joshi, 1992 "Nutrition and Dietetics" Tata Mc Grow- Hill publishing Company Ltd, New Delhi.
5. Srilakshmi. B - "Nutrition Science", V Edn, New Age International (P) Ltd, Publishers, Chennai
6. Thangam.E.Philip 1965: Modern Cookery, Orient Longman, II edition. Vol II, Bombay.

## INTERNET RESOURCES

[http://en.wikipedia.org/wiki/food\\_preservation](http://en.wikipedia.org/wiki/food_preservation)  
<https://en.m.wikipedia.org/wiki/louispasteur>  
<http://pfa.delhigovt.nic.in>  
[www.fao.org/fao-who-codexalimentarius](http://www.fao.org/fao-who-codexalimentarius)

### Concept Map

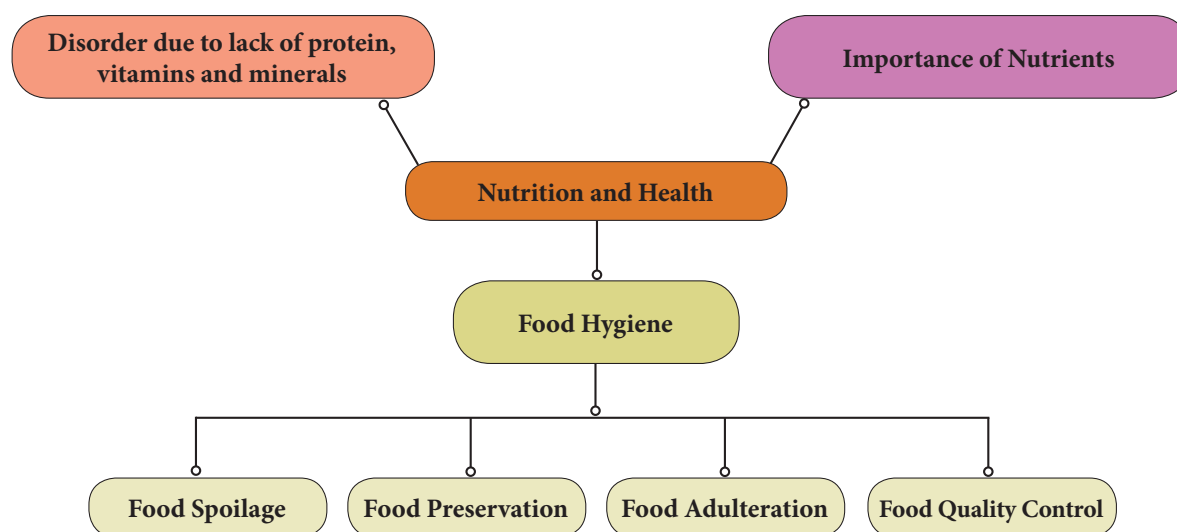

### ICT CORNER

#### Steps

1. Type the following URL in the browser or scan the QR code from your mobile.
2. A home of ICMR opens, Select Nutri Guide you can find various nutrients like Vitamins, Minerals Proteins.
3. Now Click on the Vitamins and you can find different types of Vitamins.
4. Click on any Vitamins button and a new screen will open with Vitamin chart with Biochemical, RDA, Dietary Sources Signs & Symptoms.

**URL:** <http://218.248.6.39/nutritionatlas/home.php>



B567\_9\_SCI\_EM\_T3

### Deficiency Diseases



## Learning Objectives

After completing this lesson, students will be able to

- identify different groups of bacteria based on their shape and structure.
- categorize types of viruses.
- know the role of microbes in agriculture, food industries and medicine.
- gain knowledge on modes of infection and disease transmission.
- describe the spectrum of diseases on the basis of the causative agents.
- know disease control and preventive measures.

## Introduction

Microbiology (greek words: mikros -small, bios- life bearing, logy- study), is a branch of biology that deals with living organisms of microscopic size, which include bacteria, fungi, algae, protozoa and viruses. Microbes are found in habitats like terrestrial, aquatic, atmospheric or in living hosts. Some of them survive in extreme environments like hot springs, ice sheets, water bodies with high salt content and low oxygen, and in arid places with limited water availability.

Some of the microorganisms are beneficial to us and they are used in the preparation of curd, bread, cheese, alcohol, vaccines and vitamins, while some others are harmful causing diseases to plants and animals including human being. This lesson will explore the beneficial and harmful effects of microbes in relation to welfare of human kind.

## 22.1 Microbes and their Types

Microorganisms differ from each other in size, morphology, habitat, metabolism

and several other features. Microbes may be unicellular (Bacteria), multicellular (Fungi), acellular (not composed of cells-Virus). Types of microbes include bacteria, viruses, fungi, microscopic algae and protists.

### 22.1.1 Bacteria

Bacteria are microscopic, single celled prokaryotic organisms without nucleus and other cell organelles. Although majority of bacterial species exist as single celled forms, some appear to be filaments of loosely joined cells. The size varies from less than 1 to 10  $\mu\text{m}$  in length and 0.2 to 1  $\mu\text{m}$  micrometer in width. Bacteria may be motile or non-motile. Special structures called flagella are found on the cell surfaces for motility

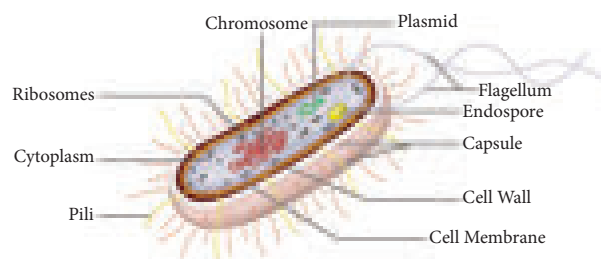

**Figure 22.1** Structure of a bacterial cell



### a. Shapes of bacteria

Based on the shapes, bacteria are grouped as:

1. Spherical shaped bacteria called as cocci (or coccus for a single cell).
2. Rod shaped bacteria called as bacilli (or bacillus for a single cell).
3. Spiral shaped bacteria called as spirilla (or spirillum for single cell).

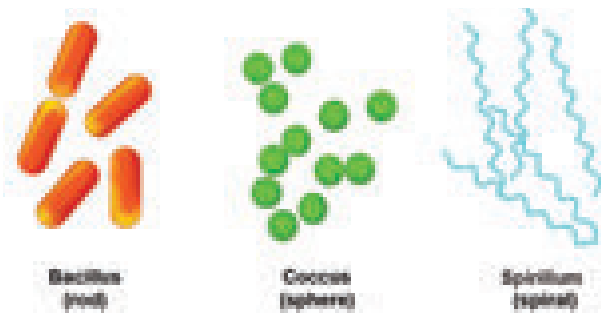

Figure 22.2 Shapes of bacteria



Antonie Van Leeuwenhoek, the first microbiologist designed his own microscope. In 1674, he took plaque from his own teeth and observed it under the microscope. He was astonished to see many tiny organisms moving around, which was otherwise invisible to naked eyes.

### b. Structure of a bacterial cell

Bacterial cell has cell membrane, covered by strong rigid cell wall. In some bacteria, outside the cell wall there is an additional slimy protective layer called **capsule** made up of **polysaccharides**. The plasma membrane encloses the cytoplasm, **incipient nucleus** (nucleoid), ribosomes and DNA which serve as genetic material. Ribosomes are the site of protein synthesis. They lack membrane bound organelles. In addition to this, a small extra chromosomal circular DNA called plasmid is found in the cytoplasm.

### 22.1.2 Viruses

The term 'virus' in Latin means 'venom' or 'poisonous fluid'. Viruses are non-cellular, **self-replicating parasites**. They are made up of a **protein** that covers a central **nucleic acid** molecule, either RNA or DNA. The amount of protein varies

from 60% to 95% and the rest is nucleic acid. Nucleic acid is either DNA (T4 bacteriophage) or RNA (Tobacco mosaic virus, TMV).

A simple virus particle is often called a **virion**. They grow and multiply only in living cells. They are the smallest among the infective agents varying over a wide range from 18-400 nm (nanometre). They can live in plants, animals, human being and even bacteria. They can be easily transmitted from one host to another.

### a. Characters of Viruses

Viruses exhibit both living and non-living characters.

#### Living characters of viruses

1. They have the nucleic acid (DNA or RNA) i.e., the genetic material that can replicate.
2. They can multiply in the living cells of the host.
3. They can attack specific hosts.

#### Non-living characters of viruses

1. Viruses remain as inert material outside their hosts.
2. They are devoid of cell membrane and cell wall. Viruses are devoid of cellular organelles like ribosomes, mitochondria, etc.
3. They can be crystallised.

### More to Know

The protein free pathogenic RNA of virus is Viroids. They are found in plant cells and cause disease in plants.

### b. Types of Viruses

Viruses are categorised as given below:

**Plant virus:** Virus that infect plants. e.g. Tobacco mosaic virus, Cauliflower mosaic virus, Potato virus.



Figure 22.3 Tobacco mosaic virus



**Animal virus:** Virus that infect animals. e.g. Adenovirus, Retrovirus(HIV), Influenza virus, Polio virus.

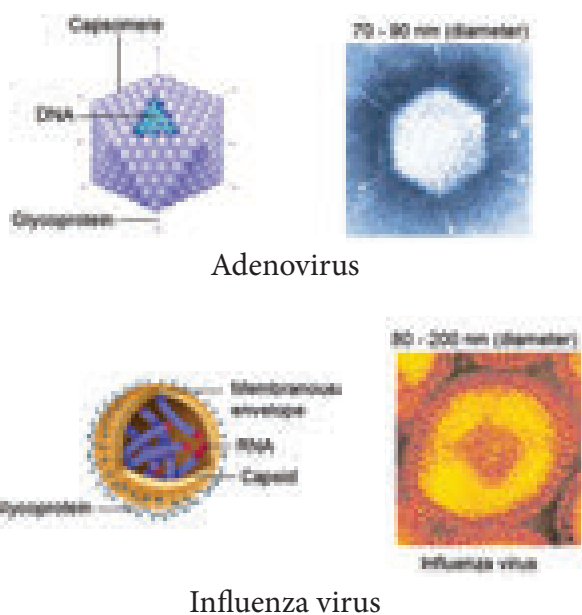

**Figure 22.4** Animal virus

**Bacteriophages:** Virus that infect bacterial cells. e.g. T4 bacteriophage.

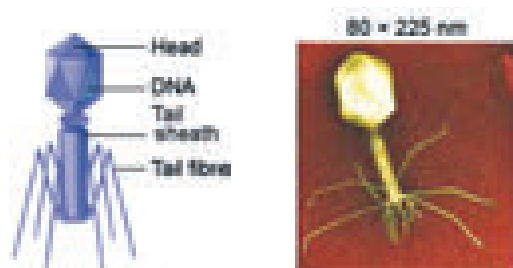

**Figure 22.5** T4 bacteriophage

### 22.1.3 Fungi

They lack chlorophyll, hence depend on living or dead host for their nutritional needs. Fungi living on living hosts are called parasites, and those living on dead organic matter are called saprophytes. The body of the fungus is called **thallus**.

Single celled yeast ranges from 1 to 5  $\mu\text{m}$  in width. They are spherical in shape. Flagella are absent and hence they are non-motile. In the case of multicellular forms, thallus is called mycelium. **Mycelium** is a complex of several thin filaments called **hyphae** (singular: Hypha).

Each hypha is 5 to 10  $\mu\text{m}$  wide. They are tube like structures filled with protoplasm and cellular organelles. Cell wall is made up of cellulose or chitin. Cytoplasm contains small vacuoles filled with cell sap, nucleus, mitochondria, golgi body, ribosomes, and endoplasmic reticulum. Food material is stored in the form of glycogen or oil globules.

They reproduce vegetatively (binary fission, budding and fragmentation), asexually (spore formation-conidia) and sexually (male and female gametangium are called antheridium and oogonium).

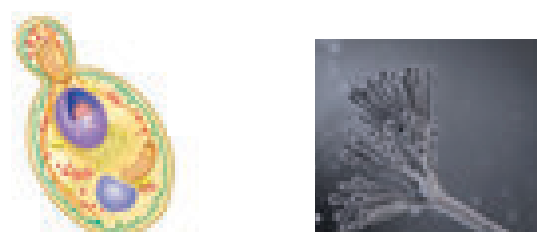

**Figure 22.6** Structure of fungi

### 22.1.4 Prions

The term 'prion' was coined by Stanley B. Prusiner in 1982. Prions are **viral particles** which contain only proteins. They do not contain nucleic acid. They are infectious and smaller than viruses. Prions are found in neurons and are rod shaped. Prions induce changes in normal proteins. This results in the degeneration of nervous tissue.

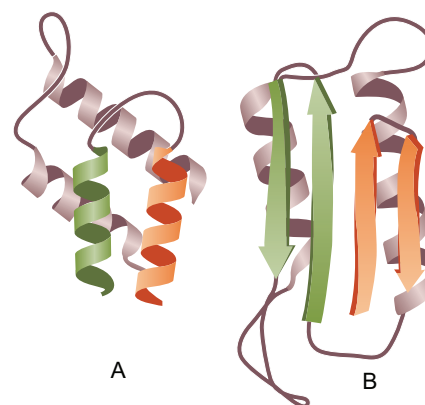

**Figure 22.7** Normal (A) and Abnormal (B) prion protein



## 22.2 Applications of Microbes

Microorganisms contribute to human welfare in many ways. In this section we will study about the diversified usefulness of microbes.



### 22.2.1 Microbes in Agriculture

Microbes play an important role in agriculture as biocontrol agents and biofertilizers. Microbes play a vital role in the cycling of elements like carbon, nitrogen, oxygen, sulphur and phosphorus. These are called biological scavengers.

**Microbes as biofertilizers:** Microorganisms which enrich the soil with nutrients are called as biofertilizers. Bacteria, cyanobacteria and fungi are the main sources of biofertilizers. Nitrogen is one of the main source of plant nutrients. Atmospheric nitrogen has to be converted to available form of nitrogen. This is done by microbes either in free living conditions or by having symbiotic relationship with the plants. e.g. *Azotobacter*, *Nitrosomonas*, *Nostoc* (free living), symbiotic microbes like *Rhizobium*, *Frankia*.

#### Activity 1

Take the root nodules of any pulse or leguminous plant available in your locality. Wash it thoroughly with water. Crush the nodules on a clean glass slide. Add a drop of distilled water to the crushed material on the glass slide. Observe the preparation under compound microscope.

**Microbes as biocontrol agents:** Microorganisms used for controlling harmful or pathogenic organisms and pests of plants are called as biocontrol agents (Biopesticides). *Bacillus thuringiensis* (Bt) is a species of bacteria that produces a protein called as 'cry' protein. This protein is toxic to the insect larva and kills them. Spores of *B.thuringiensis* are available in sachets, which are dissolved in water and sprayed on plants infected with insect larva.

### 22.2.2 Microbes in Industries

Microorganisms play an important role in the production of wide variety of valuable products for the welfare of human beings.

**Production of fermented beverages:** Beverages like wine are produced by fermentation of grape fruits by *Saccharomyces cerevisiae*.

**Curing of coffee beans, tea leaves and tobacco leaves:** Beans of coffee and cocoa, leaves of tea and tobacco are fermented by the bacteria *Bacillus megaterium*. This gives the special aroma.

**Production of curd:** *Lactobacillus sp.* converts milk to curd.

**Production of organic acids, enzymes and vitamins:** Oxalic acid, acetic acid and citric acid are produced by fungus *Aspergillus niger*. Enzymes like lipases, invertase, proteases, and glucose oxidase are derived from microbes. Yeasts are rich source of vitamin-B complex.

### 22.2.3 Microbes in Medicine

**Antibiotics:** These are metabolic products of microorganisms, which in very low concentration are inhibitory or detrimental to other microbes. In 1929, Alexander Fleming produced the first antibiotic penicillin. In human beings antibiotics are used to control infectious diseases like cholera, diphtheria, pneumonia, typhoid, etc.

**Table 22.1** Antibiotics produced by microorganisms

Class of Microorganisms	Type of Microorganism	Antibiotic produced
Bacteria	<i>Streptomyces griseus</i>	Streptomycin
	<i>Streptomyces erythreus</i>	Erythromycin
	<i>Bacillus subtilis</i>	Bacitracin
Fungi	<i>Penicillium notatum</i>	Penicillin
	<i>Cephalosporium acremonium</i>	Cephalosporin

**Vaccines:** These are prepared by killing or making the microbes inactive (attenuated). These inactive microbes are unable to cause

disease, but stimulate the body to produce antibodies against the antigen in the microbes.

**Table 22.2** Vaccines produced against diseases

Type of Vaccine	Name of the vaccine	Disease
Live attenuated	MMR	Measles, Mumps and Rubella
	BCG (Bacillus Calmette Guerin)	Tuberculosis
Inactivated (Killed antigen)	Inactivated polio virus (IPV)	Polio
Subunit vaccines (Purified antigens)	Hepatitis B vaccine	Hepatitis B
Toxoid (Inactivated antigen)	Tetanus toxoid (TT)	Tetanus
	Diphtheria toxoid	Diphtheria

## 22.3 Microbes and Diseases

Disease (dis = against; ease = comfort) can be defined as an impairment or malfunctioning of the normal state of the living organism that disturbs or modifies the performance of vital functions of the body. Disease can be categorized based on:

- i. The extent of occurrence (endemic, epidemic, pandemic or sporadic).
- ii. Whether infectious or non-infectious.
- iii. Types of pathogen – whether caused by bacterial, viral, fungal or protozoan infections.
- iv. Transmitting agent – whether air borne, water borne or vector borne.



World Health Day – 7<sup>th</sup> April  
 World Malaria Day – 25<sup>th</sup> April  
 World AIDS Day – 1<sup>st</sup> December  
 World Anti-Tuberculosis Day – 24<sup>th</sup> March

### 22.3.1 Classification of Disease based on Occurrence

**Endemic:** Disease which is found in a certain geographical area affecting a fewer number

of people (low incidence). e.g. Occurrence of goitre in Sub-Himalayan regions.

**Epidemic:** Disease which breaks out and affects large number of people in a particular geographical region and spreads at the same time. e.g. Influenza.

**Pandemic:** Disease which is widely distributed on a global scale. e.g. Acquired Immuno deficiency Syndrome (AIDS).

**Sporadic:** Disease which occur occasionally. e.g. Malaria and Cholera.

### 22.3.2 Manifestation of Disease

#### Communicability of diseases

Infectious diseases are communicable diseases. They are caused by external factors like pathogenic organisms (bacteria, virus, vectors, parasites) invading the body and causing diseases. e.g. Influenza, Tuberculosis, Chickenpox, Cholera, Pneumonia, Malaria, etc

Non-infectious diseases are non-communicable diseases. They are caused by internal factors like malfunctioning of organs, genetic causes, hormonal imbalance and immune system defect. e.g. Diabetes, Coronary heart diseases, Obesity, Cancer, Goitre, etc

#### Point of entry and place of infection

The disease causing microbes enter the body through different means. An infection develops when these pathogens enter the human body through contaminated air, water, food, soil, physical contact, sexual contact and through infected animals. They may be organ specific or tissue specific within our body where microbes reside.

#### Reservoir of infection

Reservoir of infection refers to the specific environment in which the pathogens can thrive well and multiply without causing diseases. eg. Water, soil and animal population.

#### Incubation period

The interval between infection and first appearance of the diseases is called incubation period. It may vary from few hours to several days.

## Infection

Infection is the entry, development or multiplication of an infectious agent in the human body or animals.

### 22.3.3 Harmful Effects of Microbes

Pathogens cause disease in two ways. They are tissue damage and toxin secretion.

**Tissue Damage:** Many pathogens destroy the tissues or organs of the body causing morphological and functional damage. For example, bacterium of pulmonary tuberculosis damages the cells of the lungs, and virus causing hepatitis destroys liver tissue.

**Toxin Secretion:** Many pathogens secrete poisonous substances called toxins which cause tissue damage leading to diseases.

Let us now study about the causative organism, mode of infection, occurrence, symptoms and preventive measures of a few airborne, waterborne, vectorborne and sexually transmitted diseases.



**Robert Koch** (Father of Bacteriology) is the first German physician to study how pathogens cause diseases. In 1876, he showed that the disease called anthrax of sheep was due to *Bacillus anthracis* which exist in pastures in the form of protective spores.

## 22.4 Airborne Diseases

Human beings inhale atmospheric air. Due to continuous inhalation of contaminated air the chances for airborne microorganisms to find a host and cause infection are higher.

Most of the respiratory tract infections are acquired by inhaling air containing the pathogen that are transmitted through droplets caused by cough or sneeze, dust and spores.

Airborne diseases are caused by bacteria and viruses. A few air borne diseases and their modes of transmission are given in the table below.

**Table 22.3** Airborne diseases caused by virus

Disease	Causative Organism	Mode of Transmission	Tissue/ Organ Affected	Symptoms
Common Cold	<i>Rhino virus</i>	Droplet infection	Upper respiratory tract (Inflammation of nasal chamber)	Fever, cough, running nose, sneezing and headache
Influenza	<i>Myxovirus</i>	Droplet Infection	Respiratory tract, (Inflammation of nasal mucosa, pharynx)	Fever, body pain, cough, sore throat, nasal discharge, respiratory congestion
Measles	<i>Rubeola virus</i>	Droplet infection, droplet nuclei and direct contact with infected person	Respiratory tract	Eruption of small red spots or rashes in skin, cough, sneezing, redness of eye (conjunctiva), pneumonia, bronchitis
Mumps	<i>Myxovirus parotidis</i>	Droplet infection, droplet nuclei and direct contact with infected person	Upper respiratory tract	Enlargement of parotid gland, movement of jaw becomes difficult
Chicken Pox	<i>Varicella zoster virus</i>	Droplet infection, droplet nuclei and direct contact with infected person	Respiratory tract	Eruptions of the skin, fever and uneasiness

**Table 22.4** Airborne diseases caused by bacteria

Disease	Causative Organism	Mode of Transmission	Tissue/ Organ Affected	Symptoms
Tuberculosis	<i>Mycobacterium tuberculosis</i>	Droplet infection from sputum of infected persons	Lungs	Persistent cough, chest pain, loss of weight and appetite
Diphtheria	<i>Corynebacterium diphtheriae</i>	Droplet infection, droplet nuclei	Upper Respiratory tract (nose, throat)	Fever, sore throat, choking of air passage
Whooping Cough	<i>Bordetella pertussis</i>	Droplet infection, direct contact with infected person	Respiratory tract	Mild fever, severe cough ending in whoop (loud crowing inspiration)

## 22.5 Waterborne Diseases

Microbes present in the contaminated water cause various infectious diseases. Some of the water borne diseases are cholera, typhoid,

infectious hepatitis, poliomyelitis, diarrhoea, etc. The most common waterborne diseases and their causative microbial agents, symptoms of these diseases and preventive measure are given in the tables below .

**Table 22.5** Waterborne diseases caused by virus

Disease	Causative Organism	Mode of Transmission	Tissue/Organ Affected	Symptoms	Preventive and Control Measures
Poliomyelitis	<i>Polio virus</i>	Droplet infection, sputum discharge, secretion from nose, throat, contaminated water, food and milk	Central nervous system	Paralysis of limbs	Salk's vaccine or Oral Polio Vaccine (OPV) is administered
Hepatitis A or Infectious Hepatitis	<i>Hepatitis A virus (HAV)</i>	Contaminated water, food and oral route	Inflammation of liver	Nausea, anorexia, acute fever and jaundice	Prevention of food contamination, drinking chlorinated boiled water, personal hygiene
Acute Diarrhoea	<i>Rotavirus</i>	Contaminated water, food and oral route	Intestine	Vomiting, fever, watery stools with mucus	Proper sanitation and hygiene

**Table 22.6** Waterborne diseases caused by bacteria

Disease	Causative Organism	Mode of Transmission	Tissue/ Organ Affected	Symptoms	Preventive and Control Measures
Cholera (Acute diarrhoeal disease)	<i>Vibrio cholerae</i>	Contaminated food, water, oral route and through houseflies	Intestinal tract	Acute diarrhoea with rice watery stools, vomiting, muscular cramps, nausea and dehydration	Hygienic sanitary condition, intake of Oral Rehydration Solution (ORS)
Typhoid (Enteric fever)	<i>Salmonella typhi</i>	Food and water contaminated with faeces of infected person and through houseflies	Small intestine	High fever, weakness, abdominal pain, headache, loss of appetite, rashes on chest and upper abdomen	Preventing contamination of food by flies and dust, improvement of basic sanitation, treatment with antibiotic drugs

## 22.6 Vector Borne Diseases

**Vector** is an agent that acts as an **intermediate carrier** of the pathogen. Many insects and animals act as vectors. Diseases transmitted by vectors are called vector borne diseases. These vectors can transfer infecting agents from an infected person to another healthy person. Some of the insect vector borne diseases are Malaria, Filariasis, Chikungunya, Dengue, and the diseases which are transmitted through animals are Bird flu and Swine flu.

### 22.6.1 Malaria

Malaria continues to be one of the major health problems of developing countries. Malaria is caused by **protozoan** parasite *Plasmodium*. Four species of *Plasmodium* namely, *P.vivax*, *P.malariae*, *P.falciparum* and *P.ovale* cause malaria. Malaria caused by *Plasmodium falciparum* is malignant and fatal. Approximately 300 million people around the world get infected with Malaria every year.

It spreads through the bite of an insect vector, the female *Anopheles* mosquito which feeds on human blood and usually lasts less than 10 days. A person affected by malaria will show symptoms of headache, nausea, muscular pain, chilliness and shivering, followed by rapid rise in temperature. Fever subsides with profuse sweating. Use of Quinine drugs kills the stages of malaria parasite.

### Know your Scientist



Sir Ronald Ross, an Indian born British doctor, is famous for his work concerning malaria. He worked in the Indian Medical Service for 25 years. He identified the developing stages of malarial parasite in the gastrointestinal tract of mosquito and proved that malaria was transmitted by mosquito. In 1902, he received the Nobel Prize for Physiology or Medicine for his work on the transmission of malaria.

### 22.6.2 Chikungunya

Chikungunya is caused by virus. It is transmitted in humans by the bite of infected *Aedes aegypti* mosquito during the day time. It causes severe and persistent joint pain, body rashes, headache and fever. Joint pains can last for a very long time.

Incubation period of the virus is usually 2-12 days. Chilliness, high fever, vomiting, nausea, headache, persistent joint pain and difficulty in walking are the common symptoms associated with this disease. The joints get inflamed and the person finds it difficult to walk. Paracetamol is given to relieve pain and reduce fever.

### 22.6.3 Dengue

Dengue is known as **break bone** fever. The name break bone fever was given due to the cause of intense joint and muscle pain. Dengue fever is caused by virus. It is transmitted by *Aedes aegypti* mosquito.

Incubation period of the virus is usually 5-6 days. Onset of high fever, severe headache, muscle and joint pain, rashes, haemorrhage, fall in blood platelet count are the symptoms associated with this disease. Vomiting and abdominal pain, difficulty in breathing, minute spots on the skin signifying bleeding within the skin are also associated with dengue fever. Paracetamol is given to reduce fever and body ache. Complete rest and increased intake of fluid is essential.

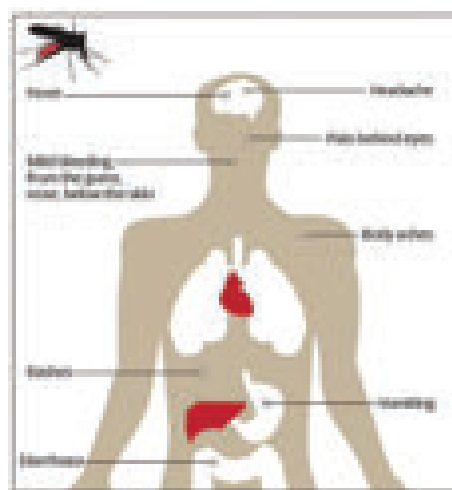

Figure 22.8 Dengue

**DO YOU KNOW?**

An extraction of tender leaves of papaya and herbal drink Nilavembu Kudineer is given to dengue patients. It is known to increase the blood platelet count. (Source: AYUSH)

### Activity 2

Observe the mosquitoes that are active during the day time. Catch them using an insect net and observe their body and legs. What do you observe?. Why are cases of Dengue reported in large numbers during post-monsoon season?

### 22.6.4 Filaria

Filariasis is a major health problem in India. This disease is caused by **nematode** worm *Wuchereria bancrofti*. The adult worms are usually found in the lymphatic system of man. It is transmitted by the bite of infected *Culex* mosquito.

Incubation period of filarial worm is 8-16 months and the symptoms include acute infection, fever and inflammation in lymph glands. In chronic infection the main feature is **elephantiasis** which affects the legs, scrotum and the arms.

### 22.6.5 Mosquitoes - Prevention and Control

- Prevention of mosquito bites by using mosquito nets, mosquito screens, mosquito repellents and ointments.
- Elimination of breeding places by providing adequate sanitation, underground waste water disposable system and drainage of stagnant water.
- Collection of water in any uncovered container such as water tank, pots, flower pots, discarded tyres should be avoided.
- Control of mosquito larvae by spraying oil on stagnated water bodies.
- Adult mosquitoes can be killed by spraying insecticides.
- Application of citronella oil or eucalyptus oil on the exposed skin.

## 22.7 Diseases Transmitted by Animals

### 22.7.1 Swine Flu

Swine Flu first originated from pigs. It is caused by virus that affects pigs and has started infecting humans. The virus spreads through air. It affects the respiratory system.

**Influeza virus H1N1** has been identified as the cause of this disease. It is transmitted from person to person by inhalation or ingestion of droplets containing virus from people sneezing or coughing. Fever, cough, nasal secretion, fatigue, headache, sore throat, rashes in the body, body ache or pain, chills, nausea, vomiting and diarrhoea, and shortness of breath are the symptoms associated with the disease.

#### Prevention and Control

- Administration of nasal spray vaccine.
- Avoiding close contact with a person suffering from flu.
- Intake of water and fruit juices will help prevent dehydration.
- Plenty of rest will help the body to fight infection.
- Always wash hands and practice good hygiene.

### More to Know

Swine flu first surfaced in April 2009 and affected millions of people. Then in June 2009 it was declared a pandemic by the World Health Organization (WHO). In 2015, India reportedly had over 31,000 people infected and 1,900 resulting deaths.

### 22.7.2 Avian Influenza

Avian influenza is a contagious bird disease caused by viruses. Birds that can carry and spread avian influenza virus include poultry (chickens, turkeys or ducks), wild birds and pet birds.

It is caused by **Influenza Virus H5N1**. The incubation period of the virus is 2-7 days. People who have close contact with infected birds or

surfaces that have been contaminated by the bird's secretion from mouth, eyes, mucus, nasal secretion or droppings (bird faeces) transmit this disease.

Fever, cough, sore throat, running nose, muscle and body aches, fatigue, headache, redness of eyes (conjunctivitis) and difficulty in breathing are the symptoms of this disease.

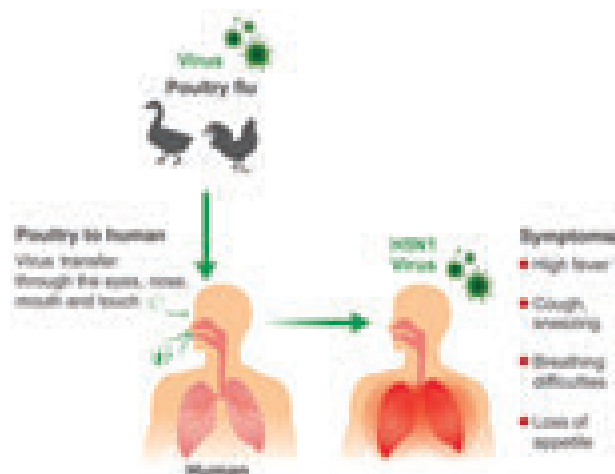

**Figure 22.9** Transmission of Avian influenza virus

### Prevention and Control

- Avoiding open air markets where infected birds are sold.
- Avoiding contact with infected birds or consumption of infected poultry.
- Proper cleaning and cooking of poultry.



The avian influenza virus A (H5N1) emerged in 1996. It was first identified in Southern China and Hong Kong. H5N1 was first discovered in humans in 1997 by World Health Organisation. First outbreak was in December 2003.

## 22.8 Sexually Transmitted Diseases

Some pathogens are transmitted by sexual contact from one partner to another and not by casual physical contact. A few sexually transmitted diseases are AIDS, Gonorrhoea, Genital warts, Genital herpes and Syphilis.

### 22.8.1 AIDS

Acquired Immunodeficiency Syndrome (AIDS) is caused by **retrovirus** (RNA virus) known as **Human Immunodeficiency Virus (HIV)**. The virus attacks the white blood cells or **lymphocytes** and weakens the body's immunity or self defence mechanism.

It is transmitted through sexual contact (from infected person to a healthy person), blood contact (transfusion of un-screened blood), by surgical equipments (infected needles and syringes), maternal – foetal transmission (from infected mother to the foetus).

Weight loss, prolonged fever, sweating at night, chronic diarrhoea are some of the important symptoms.

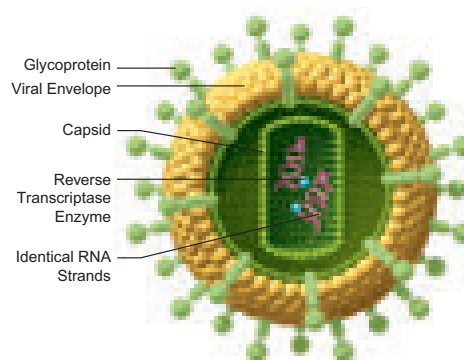

**Figure 22.10** Structure of HIV

### Prevention and Control

- Disposable syringes and needles should be used.
- Protected and safe sexual contact.
- Screening of blood before blood transfusion.
- Avoid sharing shaving blades/razors.
- People should be educated about AIDS transmission.



HIV was first recognised in Hatai (USA) in 1981. In India the first confirmed evidence of AIDS infection was reported in April 1986 from Tamil Nadu. The AIDS vaccine RV 144 trial was conducted in Thailand in 2003 and reports were presented in 2011.

## 22.8.2 Hepatitis -B or Serum Hepatitis

It occurs due to infection of **hepatitis-B virus** (HBV). The virus damages the liver cells causing **acute inflammation** and **cirrhosis** of liver.

It is transferred from infected mother to their babies or by sexual contact. It is also transmitted by contact with infected person's secretions such as saliva, sweat, tears, breast milk and blood.

Symptoms observed are fever, loss of appetite, nausea vomiting, yellowness of eyes and skin, light coloured stools, itching of skin, headache and joint pain.

### Prevention and Control

- Screening of blood donors before blood donation can prevent the transmission.
- Injection of drugs to be prevented.
- Having safe and protected sex.
- Sharing of razors should be avoided.
- The hepatitis B vaccine offers excellent protection against HBV. The vaccine is safe and highly effective.

Some of the other sexually transmitted diseases caused by bacteria and virus are discussed in Table 22.7.

## 22.9 Immunization

Immunization is a process of developing resistance to infections by administration of antigens or antibodies. Inoculation of vaccines into the body to prevent diseases is called as vaccination.

One effective way of controlling the spread of infection is to strengthen the host defenses. This is accomplished by immunization, which is one of the cost effective weapon of modern medicine.

When a large proportion of a community is immunized against a disease, the rest of the people in the community are benefited because the disease does not spread.

### 22.9.1 Vaccines and its Types

Vaccines are preparation of living or killed microorganisms or their products used for prevention or treatment of diseases. Vaccines are of two types: Live vaccines and Killed vaccines

**Live Vaccines:** They are prepared from living organisms. The pathogen is weakened and administered. e.g. BCG vaccine, oral polio vaccine.

**Table 22.7** Sexually transmitted diseases

Infectious agent	Disease	Causative Organism	Mode of Transmission	Tissue/ Organ Affected	Symptoms
<b>Bacteria</b>	Gonorrhoea	<i>Neisseria gonorrhoea</i>	Sexual contact	Urethra is affected	Discharge from genital openings, pain during urination
	Syphilis	<i>Treponema pallidum</i>	Sexual contact	Minute abrasion on the skin or mucosa, of genital area	Ulceration on genitals, skin eruption
<b>Virus</b>	Genital Herpes	<i>Herpes Simplex Virus</i>	Sexual contact, entry through mucous membrane of genital region	Genital organs of male and female individuals	Painful blisters in mouth, lips, face and genital region
	Genital Warts	<i>Human Papilloma virus</i>	Sexual contact (skin to skin)	Genital areas of male and female individuals	Vaginal discharge, itching, bleeding and burning





The process of vaccination was introduced by Edward Jenner. According to the World Health Organisation (WHO), Jennerian vaccination has eliminated small pox totally from the human population.

**Killed Vaccines:** Micro organisms (bacteria or virus) killed by heat or chemicals are called killed or inactivated vaccines. They require a primary dose followed by a subsequent booster dose. e.g. Typhoid vaccine, cholera vaccine, pertussis vaccine.

### Know your Scientist



Louis Pasteur is an 18th century French chemist and microbiologist. He coined the term vaccine. Pasteur developed vaccine against chicken pox, cholera, anthrax, etc.

### 22.9.2 Immunization Schedule

The World Health Organization in the year 1970 has given a schedule of immunization for children. This schedule is carried out in almost all countries. Table 22.8 gives the schedule of vaccination procedures followed in India.

**BCG (Bacillus Calmette Guerin):** This was prepared by two French workers Calmette and Guerin (1908-1921). The bacilli are weakened and used for immunization against tuberculosis.

**DPT (Triple Vaccine):** It is a combined vaccine for protection against Diptheria, Pertussis (whooping cough) and Tetanus.

**MMR:** Mumps, Measles, Rubella vaccine gives protection against viral infections.

**DT:** It is a dual antigen or combined antigen. It gives protection from Diptheria and Tetanus.

**TT (Tetanus Toxoid):** Toxin of Tetanus bacteria.

**TAB:** Combined vaccine for typhoid, paratyphi A and paratyphi B.

Table 22.8 Immunization Schedule

Age	Vaccine	Dosage
New born	BCG	1 <sup>st</sup> dose
15 days	Oral Polio	1 <sup>st</sup> dose
6 <sup>th</sup> week	DPT and Polio	1 <sup>st</sup> dose
10 <sup>th</sup> week	DPT and Polio	1 <sup>st</sup> dose
14 <sup>th</sup> week	DPT and Polio	1 <sup>st</sup> dose
9 – 12 months	Measles	1 <sup>st</sup> dose
18 – 24 months	DPT and Polio	1 <sup>st</sup> dose
15 months – 2 years	MMR	1 <sup>st</sup> dose
2 – 3 years	TAB	2 doses at 1 month gap
4 – 6 years	DT and Polio	2 <sup>nd</sup> booster
10 <sup>th</sup> year	TT and TAB	1 <sup>st</sup> dose
16 <sup>th</sup> year	TT and TAB	2 <sup>nd</sup> booster

### Activity 3

Recently in 2018, Nipah virus was in the headlines of the daily newspaper. Collect the following information. What is Nipah virus? How it gets transmitted? Mention the preventive measures taken by the Government to check the disease.

### Points to Remember

- ❖ Bacteria are single celled prokaryotic organisms, without a well defined nucleus (nucleoid) and other cell organelles. The genetic material is DNA.
- ❖ Viruses are small microscopic infectious agents that can multiply only inside the living cells.
- ❖ Fungi are group of eukaryotic heterotrophs which are either single celled (Yeast) or multicellular (*Penicillium*, *Agaricus*).
- ❖ Microorganisms which enrich the soil with nutrients are called as biofertilizers.

- ❖ Most of the respiratory tract infections are acquired by inhaling air containing the pathogen that are transmitted through droplets caused by cough or sneeze, dust and spores.
- ❖ Some of the air borne diseases are tuberculosis, whooping cough, diphtheria, chicken pox, mumps, measles and influenza.
- ❖ Infectious diseases that can spread through water are diarrhoea, dysentery, cholera, typhoid, hepatitis and poliomyelitis.
- ❖ Diseases transmitted by vectors are called vector borne diseases. Some of them are malaria, filaria, chikungunya and dengue.
- ❖ Diseases transmitted by animal to man are swine flu and bird flu.
- ❖ Sexually transmitted diseases such as gonorrhoea, genital warts, genital herpes, syphilis, AIDS are transmitted from one person to another by close physical contact.

## A-Z GLOSSARY

<b>Antibiotics</b>	Substances that kill or prevent the growth of microorganisms.
<b>Biofertilizer</b>	Microorganisms which enrich the soil with nutrients.
<b>Biopesticides</b>	Agents which control insect pests in natural way without causing harm to the environment.
<b>Flagella</b>	Lash-like appendage protruding from the cell body of bacterial cell.
<b>Immunisation</b>	Process by which the body produces antibodies against the specific vaccine when administered.
<b>Pathogen</b>	A biological agent that causes disease to its host. e.g. bacteria, virus etc.
<b>Prions</b>	Viral particles which contain only protein. They do not contain nucleic acid.
<b>Vaccines</b>	Preparation of antigenic proteins of pathogens (weakened or killed) which on inoculation into a healthy person provides temporary / permanent immunity against a particular disease.



## TEXTBOOK EXERCISES



### I. Choose the correct answer.

- Which of the following is transmitted through air?
  - Tuberculosis
  - Meningitis
  - Typhoid
  - Cholera
- One of the means of indirect transmission of a disease is
  - sneezing
  - coughing
  - vectors
  - droplet infection
- Diphtheria affects the
  - lungs
  - throat
  - blood
  - liver
- The primary organ infected during tuberculosis is
  - bone marrow
  - intestine
  - spleen
  - lungs
- Microbes that generally enter the body through nose are likely to affect
  - gut
  - lungs
  - liver
  - lymph nodes
- The organ affected by jaundice is
  - liver
  - lungs
  - kidney
  - brain
- Poliomyelitis virus enters the body through
  - skin
  - mouth and nose
  - ears
  - eye

## II. Fill in the blanks.

- \_\_\_\_\_ break down organic matter and animal waste into ammonia.
- Typhoid fever is caused by \_\_\_\_\_.
- H1N1 virus causes \_\_\_\_\_.
- \_\_\_\_\_ is a vector of viral disease dengue.
- \_\_\_\_\_ vaccine gives considerable protection against tuberculosis.
- Cholera is caused by \_\_\_\_\_ and malaria is caused by \_\_\_\_\_.

## III. Expand the following.

- ORS
- HIV
- DPT
- WHO
- BCG

## IV. Pick out the odd one.

- AIDS, Retrovirus, Lymphocytes, BCG,
- Bacterial disease, Rabies, Cholera, Common cold and Influenza.

## V. State whether true or false. If false, correct the statement.

- Rhizobium*, associated with root nodules of leguminous plants fixes atmospheric nitrogen.
- Non-infectious diseases remain confined to the person who develops the disease and do not spread to others.
- The process of vaccination was developed by Jenner.
- Hepatitis B is more dangerous than Hepatitis A.

## VI. Match the following.

Swine flu	Human Papilloma virus
Genital warts	Human Immunodeficiency Virus
AIDS	<i>Mycobacterium</i>
Tuberculosis	Influenza virus H1N1

## VII. Define the following.

- Pathogen
- Bacteriophages
- Vaccines
- Prions

## VIII. Answer very briefly.

- Distinguish between Virion and Viroid.
- Name the vector of the malarial parasite. Mention the species of malarial parasite which cause malignant and fatal malaria.
- What is triple antigen? Mention the disease which can be prevented by using the antigen.
- Name the chronic diseases associated with respiratory system.
- Name the organism causing diarrhoeal disease and give one precaution against it.
- Name two common mosquitoes and the diseases they transmit.

## IX. Answer briefly.

- Give an account of classification of bacteria based on the shape.
- Describe the role of microbes in agriculture and industries.
- Explain the various types of viruses with examples.
- Suggest the immunization schedule for a new born baby till 12 months of age. Why it is necessary to follow the schedule?

## X. Assertion and reason type questions.

Mark the correct statement as.

- If both A and R are true and R is correct explanation of A.
- If both A and R are true but R is not the correct explanation of A.
- If A is true but R is false.
- If both A and R are false.

**1. Assertion:** Chicken pox is a disease indicated by scars and marks in the body.

**Reason:** Chicken pox causes rashes on face and further spreads throughout the body.

**2. Assertion:** Dengue can be treated by intake of antibiotics.

**Reason:** Antibiotics blocks the multiplication of viruses.

## XI. Higher Order Thinking Skills.

1. Suggest precautionary measures you can take in your school to reduce the incidence of infectious disease.
2. Tejas suffered from typhoid while, Sachin suffered from tuberculosis. Which disease could have caused more damage and why?



### REFERENCE BOOKS

1. Michael.J Pelczar, Chan E.C.S. and Noel R Krieg, Microbiology, 5<sup>th</sup> edition, McGrawHill Education Pvt Ltd.

2. Willey, Sherwood and Wollverton, Prescott's Microbiology, 8<sup>th</sup> edition, McGrawHill Education Pvt Ltd.
3. Ananthanarayan R. and Jayaram Paniker C.K. Text of Microbiology, 10<sup>th</sup> edition, Universities Press.



### INTERNET RESOURCES

- www.biology.online.org  
 www.biologydiscussion.com  
 www.nios.ac.in.textbook.com

## Concept Map

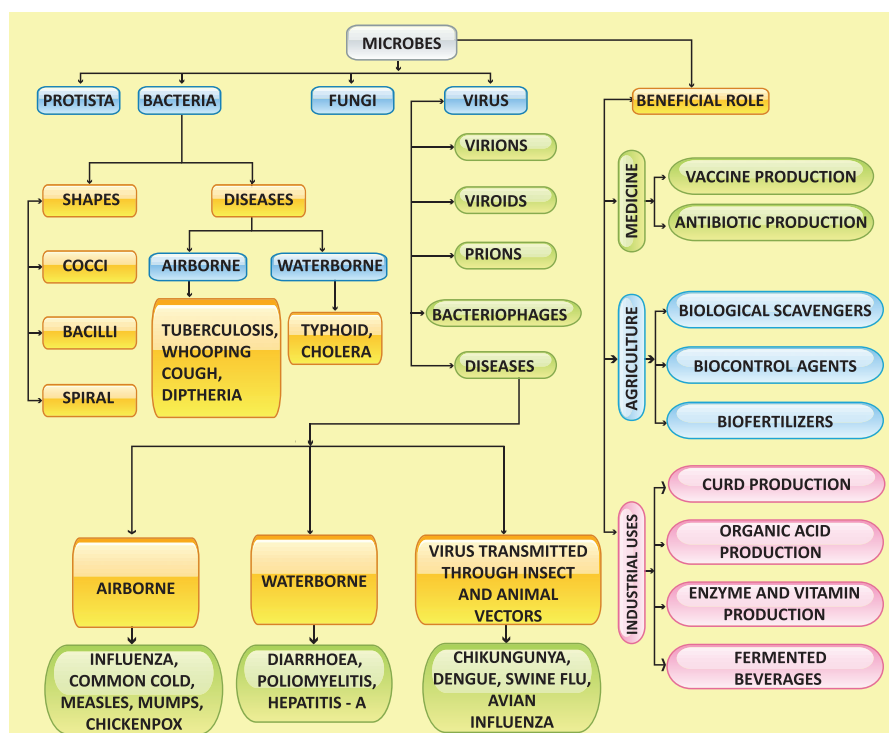

## ICT CORNER

## Microbes

### Steps

- Type the following URL to reach “Cells Alive” home page and select “Start the Animation”.
- Place the pointer on the “Bacteria Cell Model” to view the parts of the cell, or click the parts given below the animation to highlight it on the diagram.
- Click the highlighted parts to get a brief description about it.
- Click the “Speaker Icon” on the bottom of the animation to read the description for you.

**Cells alive:** URL: <https://www.cellsalive.com/cells/bactcell.htm> or Scan the QR Code.



B567\_9\_SCI\_EM\_T3



## Learning Objectives

After completing this lesson, students will be able to

- know about horticulture and floriculture.
- classify biomanures and know their importance.
- differentiate between hydroponics, aquaponics and aeroponics.
- know the importance of dairy farming and cattle breeds.
- gain knowledge on the aspects of aquaculture and pisciculture.
- gain awareness on vermicomposting methods and the benefits of vermicompost.
- identify the commercial products obtained from apiculture.

## Introduction

The gift of nature is almost unlimited and thus a variety of useful products are obtained from plants. Economic uses of plants are varied and therefore the scope for improvement and their cultivation is immense. Floriculture and horticulture have gained considerable public attraction. In recent scenario more emphasis is given to the progress of economic aspects of zoology like aquaculture (culture of fish, prawn, crabs, pearl and edible oysters), vermiculture, apiculture and dairy farming which are gaining more importance as animal-based farming due to their economic and commercial values. Animal farming has now become an agrobased entrepreneurship and is beneficial to rural farmers. We will study about them elaborately in this lesson.

### 23.1 Horticulture

Horticulture is a branch of agriculture that deals with cultivation of fruits, vegetables, and ornamental plants. The word horticulture is

derived from the latin words 'hortus' meaning garden and 'colere' meaning to cultivate. Horticulture is both a science and an art of growing plants with improved growth, quality, yield, and with resistance to diseases, insects, stress etc. There are four main classes of horticulture: (i) Pomology (fruit farming), (ii) Olericulture (vegetable farming), (iii) Floriculture (flower farming), (iv) Landscape gardening.

#### 23.1.1 Pomology or Fruit Farming

The term pomology is derived from the latin word 'pomum' means fruit and 'logy' means study. It deals with development, enhancement of fruit quality, cultivation techniques, regulation of production periods and reduction of production cost of fruits.

#### 23.1.2 Olericulture or Vegetable Farming

Olericulture is the science of growing vegetables. Vegetable farming can be classified

into: i) Kitchen or Nutrition gardening  
 ii) Commercial gardening iii) Vegetable forcing.

**Kitchen gardening:** Kitchen gardening is growing of vegetables in small scale at household. e.g. Beans, Cabbage, Lady's finger, Tomato, Brinjal, Carrot, Spinach etc.



**Figure 23.1** Kitchen gardening

**INFO BIT**



Government of Tamil Nadu has launched Uzhavan (farmer) mobile application. It can be used by farmers to gather information on farm subsidies, farm equipments, crop insurance and weather conditions. It also provides information on available stock of seeds and fertilizers in local government and private stores.

**Commercial gardening:** It is the production of vegetables in large scale to be sold in markets.



**Figure 23.2** Commercial gardening

**Activity 1**

Discuss in your class room about the importance of crop insurance to farmers.

**Vegetable forcing :** It is the method of growing vegetables in buildings, green houses, cold farms or under other artificial growing conditions. It

is the most intensive type of vegetable growing. e.g. Cabbage, Tomato, Brinjal etc.

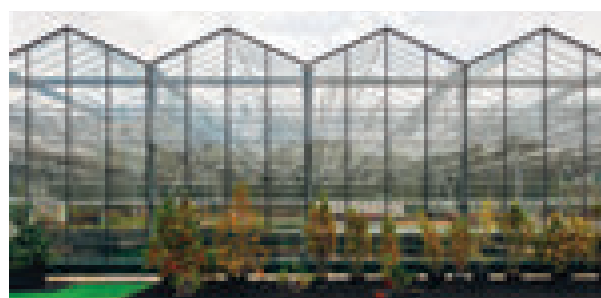

**Figure 23.3** Vegetable forcing

**Green House or Poly House:** It is a framed structure covered with transparent material to grow crops under partialiy or fully controlled environmental conditions to get optimum growth and productivity. It is the fastest growing sector in the agriculture worldwide.

**Advantages of GreenHouse**

1. Disease-free plants can be produced continuously.
2. Water requirement of crops is very less.
3. Yield is very high compared to outdoor cultivation.
4. Limited pesticide is needed.
5. It protects plants from uncertain weather.



**Figure 23.4** Green House

**23.1.3 Floriculture or Flower Farming**

Floriculture is the art of cultivation of flowering and ornamental plants in garden for beauty or floristry. It is concerned with growing traditional flowers, cut flowers, bedding plants, foliage potted plants, arboriculture trees, turf grass for beautification and value added products like essential oils, pharmaceutical

and nutraceutical compounds. Examples: Geraniums (*Pelargonium*), Busy lizzies (*Impatiens*), *Chrysanthemum* and *Petunia*.



**Figure 23.5** Flower Farming

#### INFO BIT

#### Pradhan Mantri Fasal Bima Yojana (PMFBY)

It is an agricultural crops insurance scheme of Indian government. Under this scheme the central government provides insurance cover and financial assistance to farmers. It was launched on 18th February 2016.

#### Uses of flowers

1. Flowers are used for decoration purpose.
2. They are also used for personal needs and, religious and ceremonial offerings.
3. They impart colour and beauty to the garden.
4. They increase country's economy.

#### 23.1.4 Landscape Gardening

Landscape horticulture is the study of designing and constructing landscapes in homes, business firms and public areas to imitate natural scenery

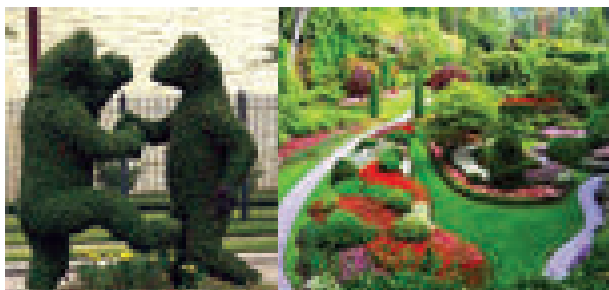

**Figure 23.6** Landscape gardening

## 23.2 Manuring (Biomanuring)

Organic manures are predominantly derived from plant debris, animal faeces and microbes. They make the soil fertile by adding nutrients like nitrogen. Few of them are listed below.

### 23.2.1 Animal Manure

It consists of faeces and urine from livestock like cattle, horses, pigs, sheep, chickens, turkeys, rabbits, etc. Manures from different animals have different qualities and different applications.

**Farmyard manure:** It is a mixture of cattle dung, urine, litter material and other dairy wastes. On an average well decomposed farm yard manure contains 0.5% Nitrogen, 0.2% available phosphate and 0.5% available potash.

**Sheep and Goat manure :** It contains higher nutrients than farm yard manure. It contains 3% Nitrogen, 1% phosphorus pentoxide and 2% potassium oxide.

### 23.2.2 Compost

Compost is a soil conditioner as well as a fertilizer, that is rich in nutrients. It is produced by natural decomposition of organic matter such as crop residues, animal wastes, food wastes, industrial and municipal wastes by microorganisms under controlled conditions.

### 23.2.3 Green Manure

Green manure is obtained by collection and decomposition of green leaves, twigs of trees, field bunds etc. Green manure improves soil structure, increases water holding capacity and decreases soil loss by erosion. It also helps in reclamation of alkaline soils and reduces weed proliferation. It is a manure obtained from undecomposed green material derived from leguminous plants e.g. Sunhemp (*Crotalaria juncea*), Dhaincha (*Sesbania aculeata*), Sesbania (*Sesbania speciosa*).

## 23.3 Biofertilizers

Biofertilizers are substances that contain living microorganisms which, when applied

to seeds, plant surfaces, or soil, colonize the rhizosphere or the interior of the plant and promote growth by increasing the supply or availability of primary nutrients to the host plant.

### 23.3.1 Types of Biofertilizers

**Rhizobium:** *Rhizobium* is a soil bacterium that colonize the roots of leguminous plants to form root nodules. The bacteria fix atmospheric nitrogen and convert them to ammonia.

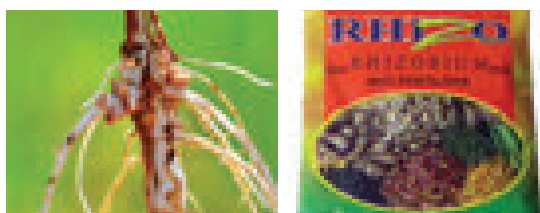

Figure 23.7 *Rhizobium* biofertilizer

**Azospirillum:** *Azospirillum* bacteria has the ability to use atmospheric nitrogen and transport this nutrient to the crop plants. It is inoculated on maize, barley, oats and sorghum crops. It increases productivity of cereals by 5 - 20%, of millets by 30% and fodder by over 50%.



Figure 23.8 *Azospirillum* biofertilizer

**Azotobacter:** Application of *Azotobacter* bacteria has been found to increase yield of wheat, rice, maize and sorghum. Apart from nitrogen fixation, these organisms are capable of producing antifungal and antibacterial compounds.



Figure 23.9 *Mycorrhizae* biofertilizer

**Mycorrhizae:** These fungi have symbiotic association with the roots of vascular plants. They increase the uptake of phosphorus. e.g. Citrus, Papaya.

**Azolla:** *Azolla* is a free floating, aquatic fern found on water surfaces having a cyanobacterial symbiotic association with *Anabaena*. It is a live floating nitrogen factory using energy from photosynthesis to fix atmospheric nitrogen.



Figure 23.10 *Azolla* biofertilizers

#### Info bits Biofertilizer Scheme

Tamil Nadu Government has recently launched 'Biofertiliser Scheme'. It is aimed at better management of natural farming and helps to boost and maintain soil fertility.

### 23.4 Medicinal Plants

The history of medicinal plants is as old as the history of human beings. Most medicines are obtained either directly or indirectly from plants. All the major system of medicines such as Ayurveda, Yoga, Unani, Siddha, Homeopathy (AYUSH) use drugs obtained from plants and animals. These drugs from medicinal plants are called secondary metabolites. Plants produce primary metabolites for their own living e.g. carbohydrates, amino acids etc., and secondary metabolites for protection, competition and species interaction. e.g. alkaloids, terpenoids, flavonoids etc. Phytochemistry is the study of phytochemicals which are chemical substances derived from various parts of the plant. Few plant derived drugs are described in (Table 23.1).

#### Activity 2

Collect at least five medicinal plants from your locality. Identify the plant and try to find out its medicinal value.



**Table 23.1** Drugs derived from Medicinal plants

S. No.	Tamil Name	Botanical Name	Drug	Parts used	Disease cured
1	Katrazhai	<i>Aloe vera</i>	Anthraquinones	Leaves	Heal wounds, Skin disease, Cancer, Psoriasis
2	Tulsi	<i>Ocimum sanctum</i>	Essential oil	Leaves	Cold, Fever, Skin disease
3	Nannari	<i>Hemidesmus indicus</i>	Terpene	Roots	Bacterial infections, Diarrhoea
4	Nilavembu	<i>Andrographis paniculata</i>	Terpenoids	All parts	Dengue fever, Diabetes, Chikungunya
5	Vetpalai	<i>Wrightia tinctoria</i>	Flavonoids	Latex, Leaves	Psoriasis, Diarrhoea, Swellings
6	Cinchona maram	<i>Cinchona officinalis</i>	Quinine	Bark	Malaria, Pneumonia
7	Chivan Amalpodi (Sarpagandha)	<i>Rauwolfia serpentina</i>	Reserpine	Root	Blood pressure, Antidote for Snake bite
8	Thaila maram	<i>Eucalyptus globulus</i>	Essential oil	Leaves	Fever, Headache
9	Pappali	<i>Carica papaya</i>	Papain	Leaf, Seed	Dengue
10	Nithya kalyani	<i>Catharanthus roseus</i>	Alkaloids	All parts	Leukemia, Cancer

**Info bits**

The Council of Scientific and Industrial Research (CSIR) and National Botanical Research Institute (NBRI) and Central Institute for Medicinal and Aromatic Plants (CIMAP) have jointly launched India's first anti diabetic ayurvedic drug **BGR -34** (BGR-Blood Glucose Regulator). It contains 34 identified active phytoconstituents from herbal resources. It works by controlling blood sugar levels.

**23.5 Mushroom Cultivation**

Mushroom cultivation is a technology of growing mushrooms using plant, animal and industrial waste. In short it is wealth out of waste technology. This technology has gained importance worldwide because of its dietary fibres and protein value. Mushroom is a fungi belonging to basidiomycetes. It is rich in proteins, fibres, vitamins and minerals. There are more than 3000 types of mushrooms. e.g. Button mushroom (*Agaricus bisporus*), Oyster mushroom (*Pleurotus* spp.), Paddy straw mushroom (*Volvariella volvacea*). The cultivation takes one to three months. Major stages of mushroom cultivation are explained below.

**Composting:** Compost is prepared by mixing paddy straw with number of organic materials like cow dung and inorganic fertilizers. It is kept at about 50 °C for one week.

**Spawning:** Spawn is the mushroom seed. It is prepared by growing fungal mycelium in grains under sterile conditions. Spawn is sown on compost.

**Casing:** Compost is covered with a thin layer of soil. It gives support to the growing mushroom, provides humidity and helps regulate the temperature.

**Pinning:** Mycelium starts to form little bud, which will develop into mushroom. Those little white buds are called pins.

**Harvesting:** Mushroom grow better in 15°C - 23°C. They grow 3 cm in a week which is the normal size for harvesting. In the third week the first flush mushroom can be harvested.

**Fig 23.11** Mushrooms

**Preservation:** Discolouration, weight and flavour loss are the main problems during harvesting of

mushrooms. The following methods are used to increase their life.

- (i) Freezing           (ii) Drying
- (iii) Canning       (iv) Vacuum Cooling
- (v) Gamma radiation and storing at 15°C.

## 23.6 Hydroponics

Hydroponics is the method of growing plants without soil, using mineral nutrient solutions in water. The containers are made of glass, metal or plastic. They range in size from small pots for individual plants to huge tank for large scale growing. It was demonstrated by a German Botanist Julius Von Sachs in 1980. Hydroponics is successfully employed for the commercial production of seedless cucumber and tomato. Plants are suspended with their roots submerged in water that contain plant nutrients. The roots absorb water and nutrients, but do not perform the anchoring function. Therefore, the plants must be mechanically supported from above.

### Importance of hydroponics

- (i) Conservation of water and nutrients.
- (ii) Controlled plant growth.
- (iii) In deserts and Arctic regions hydroponics can be an effective alternative method.

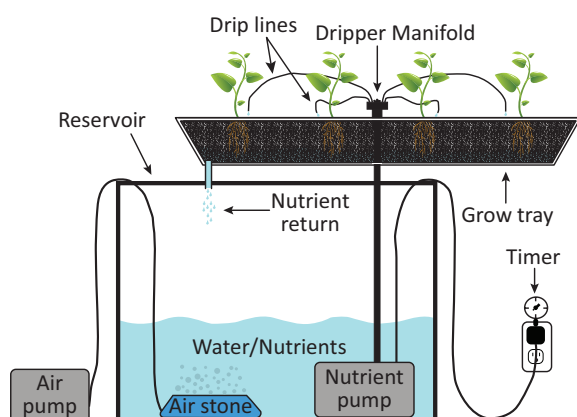

Figure 20.12 Hydroponics

## 23.7 Aeroponics

The aeroponic system is the high-tech type of hydroponic gardening. The growth medium in this type is primarily air. The roots hang in the air and are misted with nutrient solution. The misting is usually done for every few minutes,

as roots will dry out rapidly if the misting cycles are interrupted. A timer controls the nutrient pump much like other types of hydroponic systems, except that the aeroponic system needs a short cycle timer that runs the pump for a few seconds every couple of minutes.

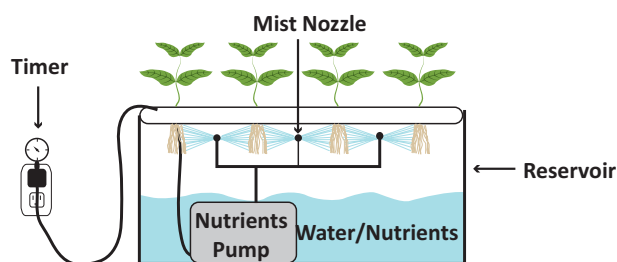

Figure 20.13 Aeroponics

## 23.8 Aquaponics

Aquaponics is a system of a combination of conventional aquaculture with hydroponics in a symbiotic environment, in which plants are fed with the aquatic animals' excreta or wastes. These wastes are broken down by nitrifying bacteria initially into nitrites and later into nitrates that are utilized by the plants as their nutrients. Thus, the wastes are utilized and water is recirculated back to the aquaculture system.



Aquaponics consists of two main parts, aquaculture- for raising aquatic animals like fish and hydroponics-for raising plants. Green leafy vegetables like chinese cabbage, lettuce, basil, coriander, parsley, spinach and vegetables like tomatoes, capsicum, chillies, bell peppers, sweet potato, cauliflower, broccoli and egg plant can be grown in aquaponics.



Figure 23.14 Aquaponics

## 23.9 Dairy Farming

Dairy farming involves rising of cattle for milk production. It involves the proper maintenance of cattle, along with collection and processing of milk and milk products which are useful to man. Dairying is the production and marketing of milk and its products.

### 23.9.1 Cattle Breeds

The Indian cattle include cows and buffaloes. They are domesticated for milk, meat, leather and transportation. They belong to two different species, *Bos indicus* (Indian cows and bulls) and *Bos bubalis* (buffaloes). These cattle animals are reared for milk and farm labour. They are classified into three types: Dairy breeds, Draught (or) Draft breeds, Dual purpose breeds.

**a. Dairy breeds:** Dairy animals are domesticated for obtaining milk. The cows (milk producing females) are high milk yielders (**milch animals**). The dairy breeds are:  
a) Indigenous breeds b) Exotic breeds.

Indigenous breeds are native of India. They include **Sahiwal, Red Sindhi, Deoni and Gir**. These cattle are well built with strong limbs, prominent hump and loose skin. Milk production depends on the duration of the lactation period (the period of milk production after the birth of a calf). These local breed animals show excellent resistant to diseases.

Exotic breeds (*Bos taurus*) are imported from foreign countries. They include **Jersey, Brown Swiss and Holstein-Friesian** etc. These foreign breeds are selected for long lactation periods.

**b. Draught (or) Draft breeds:** They are used for agricultural work, such as tilling, irrigation and carting. These include **Amritmahal, Kangayam, Umblachery, Malvi, Siri and Hallikar** breeds. Bullocks are good draft animals while the cows are poor milk yielders.

**c. Dual purpose breeds:** The cows of these breeds provide milk and the bulls are useful for farm work. In India these breeds are favoured by farmers. They include **Haryana, Ongole, Kankrej and Tharparkar**.

#### Info bits

##### Indigenous Draught breeds - Native to Tamil Nadu

**Kangayam:** It originated in Kangayam and is observed in Dharapuram, Perundurai, Erode, Bhavani and part of Gobichettipalayam taluk of Erode and Coimbatore district.

**Pulikulam:** This breed is commonly seen in Cumbum valley of Madurai district in Tamil Nadu. It is also known as Jallikattu madu, They are mainly used for penning in the field and useful for ploughing.

### 23.9.2 Composition of Cattle Feed

The food requirement for cattle should support healthy life of the animal and milk producing requirement. The feed for dairy cattle is broadly classified into two: Roughages and Concentrates

**Roughage** is a coarse and fibrous fodder. It consists of succulent feed (cultivated grass, fodder and root crops) and dry fodder (hay, straw and chaff).

**Concentrates** are low in fibre and contain high level of carbohydrates, protein and other nutrients. A variety of raw materials such as cholam (jowar), kambu (pearl millet), ragi (finger millet), rice bran, wheat bran, cotton seed cake, mustard cake, linseed cake, groundnut cake, mango seed, neem cake and yellu (sesame) cake can be used to make concentrate feed. They should also be fed on green fodder (maize, lucerne, berseem, millet, and elephant grass).

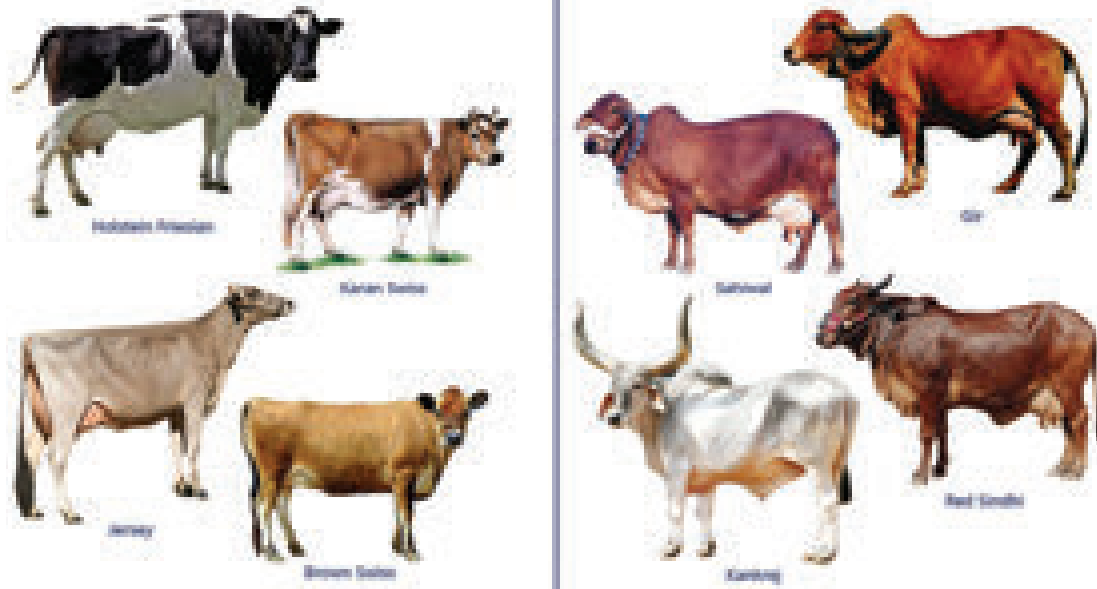

Figure 23.15 Cattle breeds

### 23.9.3 Feed Management

Dairy cattle need balanced rations containing all nutrients in proportional amounts and food additives which contain minerals, vitamins, antibiotics and hormones to promote the growth of animals, good yield of milk and to protect them from diseases. The daily average feed ratio of a milking cow is:

- (i) 15-25 kg of roughage (dry grass and green fodder)
- (ii) 4-5 kg of grain mixture
- (iii) 100-150 litres of water



**Dr. Verghese Kurein**, was the founder of National Dairy Development Board (NDDB) and was called the **Architect of India's Modern Dairy Industry** and the **Father of White Revolution**. NDDB designed and implemented the world's largest dairy development programme called **OPERATION FLOOD**.

### 23.9.4 Improvement of Livestock Development in India

Improved breeding techniques in cattle have tremendously increased the production of new breeds with high capacities.

### Intensive Cattle Development Programme:

It is based on cross breeding of indigenous cows with exotic (European) breeds to increase milk production. New methods and modern equipments are made available for machine – milking of cows.

**Operation Flood Programme:** It is based on dairy commodity aid to increase milk supply in urban areas.

## 23.10 Aquaculture

Aquaculture is the rearing of economically important aquatic organisms like fishes, prawns, shrimps, crabs, lobsters, edible oysters, pearl oysters and seaweeds under controlled and confined environmental conditions using advanced technologies.

### 23.10.1 Types of Aquaculture

Aquaculture is classified into:

1. Freshwater aquaculture
2. Marine water aquaculture (Mariculture)

**Freshwater aquaculture:** The rearing of aquatic organisms in freshwater is called freshwater aquaculture. Culture of organisms is carried out in pond, river, dam, lake and cold water. These freshwater resources remain within the land. Tilapia, carps (Catla, Rohu, Mrigal), catfishes, and air breathing fishes are cultured in freshwater.

### Info bits

Tamil Nadu is a leading state endowed with rich fishery resources from Marine, Inland and Coastal Aquaculture. The marine fisheries potential of the state is estimated at 0.719 million tonnes. The inland fishery resources have a potential to yield 4.5 lakh metric tonnes of fishes. Tamilnadu ranks sixth among the maritime states in coastal farming.

**Marine water aquaculture:** The cultivation of aquatic organisms is in sea water. This is also referred as Mariculture or Sea farming. Culture of organisms is carried out along the sea coast (inshore area) and in deep sea. Organisms like shrimps (marine prawns), pearl oysters, edible oysters, mussels and fin fishes like salmon, sea bass, milk fishes and mullets are cultured in marine water.

### 23.10.2 Prospects of Aquaculture

Aquaculture has become the fastest growing food producing sector to meet the demands of food and nutrition to the growing population through increased production from aquatic food resources. It aims at blue revolution. It is a major source of export and foreign exchange earnings for the country. It generates employment through fish farming in rural and under developed area.

## 23.11 Pisciculture

Pisciculture or Fish culture is the process of breeding and rearing of fishes in ponds, reservoirs (dams), lakes, rivers and paddy fields. It is the farming of economically important fishes under controlled conditions.

### 23.11.1 Types of Fish Culture

**Extensive fish culture:** Culture of fishes in large areas with low stocking density and natural feeding.

**Intensive fish culture:** Culture of fishes in small areas with high stocking density and providing artificial feed to increase production.

### Info bits

The Central Marine Fisheries Research Institute (CMFRI) was established by the Government of India in 1947 at Cochin, Kerala State. Its main focus is on marine fisheries landings, research on taxonomy and bioeconomic characteristics of marine organisms.

The Central Institute of Brackish Water Aquaculture (CIBA) was established in 1987 with its headquarters at Chennai. The objective of CIBA is management of sustainable culture system for fin fish and shell fish in brackish water. CIBA assists small aquafarmers in fin fish and shrimp farming by providing sustainable modern technologies.

**Monoculture:** It is the culture of single type of fish in a water body. It is also called mono species culture.

**Polyculture:** It is the culture of more than one type of fish in a water body. It is also called composite fish culture.

**Integrated fish farming:** It is the culture of fishes along with agricultural crops or animal husbandry farming. Rearing of fish along with paddy, poultry, cattle, pig and ducks.

### 23.11.2 Types of Ponds for Fish Culture

Fish farm requires different types of pond for the various developmental stages of fish growth. They are given below:

**Breeding pond:** Healthy and sexually mature male and female fishes are collected and introduced in this pond for breeding. The eggs released by the female are fertilized by the sperm and fertilized eggs float in water as frothy mass.

**Hatching pits:** The fertilized eggs are transferred to hatching pits or hatching hapas for hatching.

**Nursery ponds:** The hatchlings are transferred from hatching pits after 2 to 7 days. The hatchlings grow into fry and are cultured in these ponds for about 60 days with proper feeding till they reach 2 - 2.5 cm in length.

**Rearing ponds:** Rearing ponds are used to culture the fry. The fish fry are transferred from nursery pond to rearing ponds and are maintained for about three months till they reach 10 to 15 cm in length. In these rearing ponds the fry develops into fingerlings.

**Stocking pond:** The stocking pond is also called as culture pond or production pond. These ponds are used to rear fingerlings upto the marketable size.

### 23.11.3 Cultivable Food Fishes

**Freshwater cultivable fishes:** Indian major carps (Kendai) – Catla, Rohu, Mrigal, catfishes (Keluthi), Murrels (Veral) and Tilapia (Jilebi kendai) are cultured in freshwater.

**Marine water cultivable fishes:** Sea bass (Koduva), Grey mullet (Madavai) and *Chanos chanos* (Milk fish) are the fishes cultured in marine water.

### 23.11.4 Nutritional Value of Fishes

Cultivable freshwater and marine food fishes are highly nutritious, rich source of animal proteins and are easily digestible. They are rich in essential amino acids such as lysine and methionine, polyunsaturated fatty acid (PUFA),

minerals like calcium, phosphorus, iron, sodium, potassium and magnesium. Fat soluble vitamins A, D and water soluble B-complex vitamins like pyridoxine, cyanocobalamine and niacin.

### Activity 3

Visit a fish farm near your locality and collect information about the following:

- Different types of pond you see.
- Different varieties of fishes in the pond.
- Type of feed and their ingredients used to prepare feed.

## 23.12 Prawn Culture

One of the most economically important shell fish resources of India are prawns. They are of great demand both in the local and international market. Due to their great taste, they are a cherished delicacy to be served as food. In view of their popularity and marketing avenues in foreign countries there is a need for developing advanced technology and intensify prawn culture in India.

### 23.12.1 Types of Prawn Culture

A number of species of prawns of different sizes are found distributed in water resources. Only those prawns which are good in size, weight, available in plenty and easily cultivable are commonly selected for prawn culture on commercial basis.

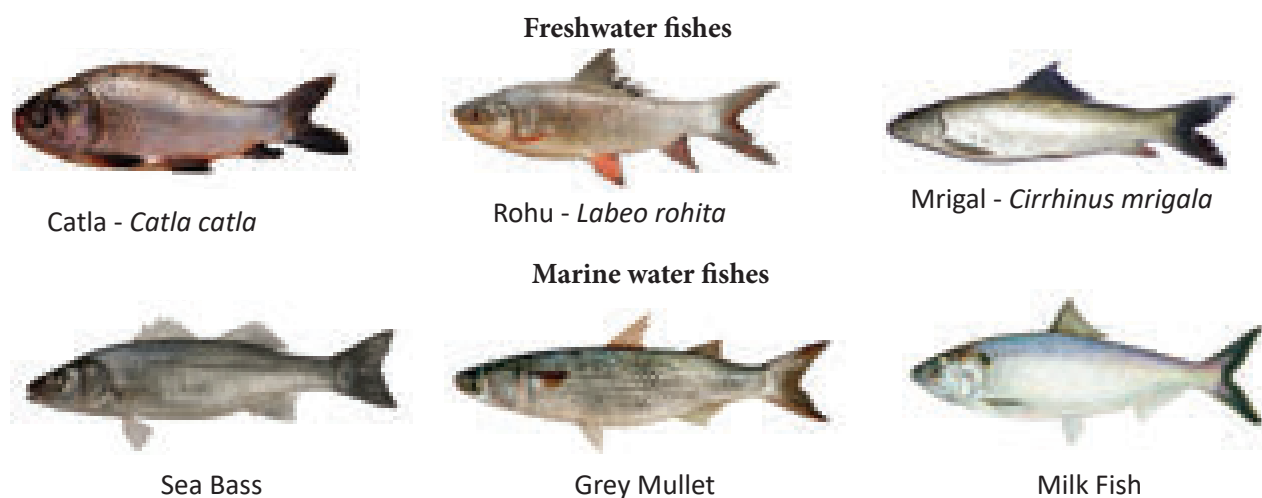

**Figure 23.16** Freshwater and Marine water fishes

### Marine water prawn culture

The rearing of marine penaeid prawn is called marine prawn culture or **shrimp culture**. *Penaeus indicus* and *Penaeus monodon* are cultured in marine water.



**Figure 23.17** Marine water prawn

### Freshwater prawn culture

The rearing of freshwater prawn is called freshwater prawn culture. *Macrobrachium rosenbergii* and *Macrobrachium malcomsonii* are cultured in freshwater.



**Figure 23.18** Freshwater prawn

### 23.12.2 Methods of Prawn Culture

The methods employed for prawn culture are:

- a. Seed collection and hatchery method
- b. Paddy cum prawn culture method

#### Seed collection and hatchery method

The larvae and juveniles obtained by collection from natural resources (estuaries, and backwaters) or by hatchery methods (controlled breeding). They are reared and grown into adults.

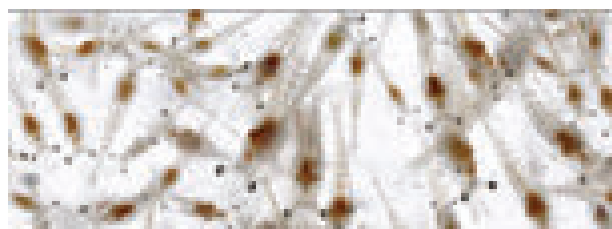

**Figure 23.19** Post larvae (Prawn seed)

### Paddy cum prawn culture

It is also called Pokkali culture. It is the oldest and traditional method of prawn culture practiced in Kerala. The low lying paddy fields along the coastal areas serve as suitable grounds for prawn culture. Prawns are cultured in these fields after the harvest of paddy.



**Figure 23.20** Paddy cum prawn/fish culture

## 23.13 Vermitechnology

The awareness of organic matter and concept of sustainable agriculture is gaining importance among our farmers in the recent years to produce good quality crops. Maintenance of soil organic matter is very important for sustainable productivity and this is attained by vermiculture.

### 23.13.1 Vermiculture

Vermiculture involves the artificial rearing or cultivation of earthworms and using them for the production of compost from natural organic wastes.

#### Earthworm Species used for Vermiculture:

The earthworms used for vermicompost production are *Perionyx excavatus* (Indian blueworm), *Eisenia fetida* (Red worms), *Eudrilus eugeniae* (African night crawler).

### 23.13.2 Vermicomposting

It is an important component of organic farming which can convert bio-wastes into nutrient rich organic manure by using earthworms. It feeds on the organic wastes





*Perionyx excavatus*

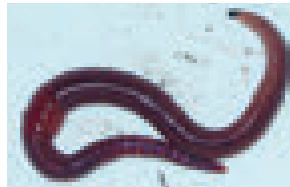

*Eisenia fetida*



*Eudrilus eugeniae*

**Figure 23.21** Earthworm species for vermicomposting

and excrete it in digested form known as castings. The compost is generally called vermicompost.

### Vermicompost

Vermicompost is the excreta (worm castings) which is a fine, granular organic matter formed by the decomposition of organic materials by the earthworm. It is an ideal fertilizer for the soil.

### Vermicomposting Materials

Biologically degradable organic wastes are used as potential organic resources for vermicomposting. They are:

- Agricultural wastes (crop residue, vegetables waste, sugarcane trash)
- Crop residues (rice straw, tea wastes, cereal and pulse residues, rice husk, tobacco wastes, coir wastes)
- Leaf litter
- Fruit and vegetable wastes
- Animal wastes (cattle dung, poultry droppings, pig slurry, goat and sheep droppings)
- Biogas slurry

### Vermicomposting by Bin Method

It is the rearing of earthworms in a container or bin. The container is half filled with bedding materials such as shredded cardboard, leaves, paddy husk, chopped straw, saw dust and manure. Small quantity of soil and sand is added to provide necessary grit for the worms. The bedding material should be moistened by adding water that enables free movements of the worms. The worms are gently placed and spread evenly on the bedding.

Organic wastes (kitchen wastes, vegetable and fruit wastes) are added which are fed by the earthworms. The bin is covered with coconut leaves or gunny bags to conserve moisture, provide darkness and keep out of pests. After a period of 60 days the wastes are completely transformed into nutrient rich materials that are excreted by earthworms known as **worm castings**. These castings are harvested and used as organic manure.

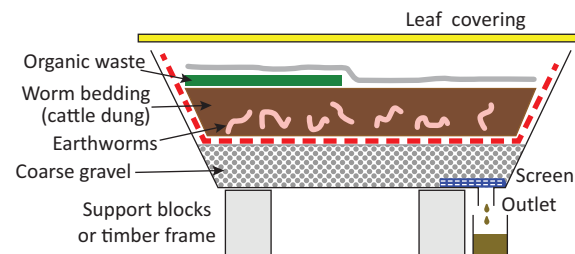

**Figure 23.22** Vermicomposting bin

### Activity 4

Prepare vermicompost from organic waste materials present in your school surroundings and garden. The above activity can be done in a circular container/ bin and kept in shady place with optimal temperature and light.

### Advantages of Vermicompost

Vermicompost is dark brown in colour and similar to farmyard manure in colour and appearance.

- It is a rich source of nutrients essential for plant growth. It makes the soil fertile.



- It improves the water holding capacity and helps to prevent soil erosion.
- It contains valuable vitamins, enzymes and growth regulator substances for increasing growth, vigour and yield of plants.
- It enhances decomposition of organic matter in soil.
- Vermicompost is free from pathogens and toxic elements.
- Vermicompost is rich in beneficial microflora.

## 23.14 Apiculture

Apiculture is the rearing of honey bee for honey. It is also called Bee keeping. It is a profitable rural based industry. Honey bees are domesticated by farmers to produce honey.

### 23.14.1 Types of Honey Bee

There are three types of individuals in an honey bee colony namely the queen bee, the drones and the worker bees.

**Queen Bee:** The queen is the largest member and the fertile female of the colony. They are formed from fertile eggs. The queen is responsible for laying eggs in a colony.

**Drones:** They are the fertile males. They develop from unfertilized eggs. They are larger than the workers and smaller than the queens. Their main function is to fertilize the eggs produced by the queen.

**Worker Bees:** They are sterile female bees and are the smallest members of the colony. Their function is to collect honey, look after the young ones, clean the comb, defend the hive and maintain the temperature of the bee hive.

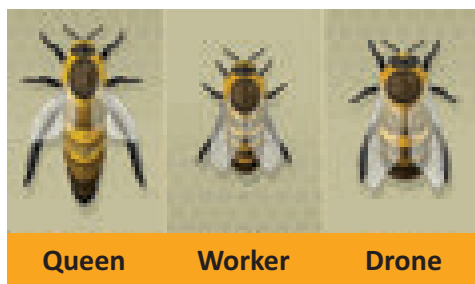

Figure 23.23 Types of Honey bee

### 23.14.2 Varieties of Honey Bee

#### Indigenous varieties

- Apis dorsata* (Rock bee or Wild bee)
- Apis florea* (Little bee)
- Apis indica* (Indian bee)

#### Exotic varieties

- Apis mellifera* (Italian bee)
- Apis adamsoni* (African bee)

### 23.14.3 Structure of Bee Comb

The comb of the bees is formed mainly by the secretion of the wax glands present in the abdomen of the worker bee. A comb is a vertical sheet of wax with double layer of hexagonal cells.

**Formation of Honey:** The honey bees suck the nectar from various flowers. The nectar passes to the honey sac. In the honey sac, sucrose present in the nectar mixes with acidic secretion and by enzymatic action it is converted into honey which is stored in the special chambers of the hive.

Quality of honey depends upon the flowers available to the bees for nectar and pollen collection.

### 23.14.4 Products from Honey Bee

Honey bees are used in the production of honey and bee wax. Other useful products obtained from honey bees are bee pollen, royal jelly, propolis and bee venom.

**Honey:** Honey is a sweet, viscous, edible natural food product. Dextrose and sucrose gives sweet taste to the honey. It also contains amino acids, B-complex vitamins, ascorbic acid, and minerals. Formic acid is a preservative in honey. Invertase is an enzyme present in honey.

#### Uses of Honey

- Honey has an antiseptic and antibacterial property. It is a blood purifier.
- It helps in building up of haemoglobin content in the blood.
- It is used in Ayurvedic and Unani system of medicines.
- It prevents cough, cold, fever and relieves sore throat.

- It is a remedy for ulcers of tongue, stomach and intestine.
- It enhances digestion and appetite.



- Honey bee visits 50 to 100 flowers during a collection trip.
- Average bee will make only 1/12<sup>th</sup> of a teaspoon of honey in its lifetime.
- One kilogram of honey contains 3200 calories and is an energy rich food.

### Points to Remember

- ❖ Horticulture, is a branch of agriculture that deals with cultivation of fruits, vegetables, and ornamental plants.
- ❖ The organic manures are predominantly derived from plant debris, animal faeces, microbes. They make the soil fertile.
- ❖ Mushroom cultivation is a technology of growing mushrooms using plant, animal and industrial waste.
- ❖ Hydroponics is the method of growing plants without soil, using mineral nutrient solutions in water.
- ❖ The aeroponic system is high-tech type of hydroponic gardening and the growth medium is primarily air.
- ❖ Dairy farming involves raising of cattle for milk production.
- ❖ Aquaculture is the rearing of economically important aquatic organisms like fishes, prawns, shrimps, crabs, lobsters, edible oysters, pearl oysters and sea weeds under controlled and confined environmental conditions using advanced technologies.
- ❖ Pisciculture or fish culture is the process of breeding and rearing of fishes in ponds, reservoirs (dams), lakes, rivers and paddy fields.
- ❖ Vermiculture involves the artificial rearing or cultivation of earthworms and using them for the production of compost from natural organic wastes.

## A-Z GLOSSARY

<b>Aquaponics</b>	Combination of conventional aquaculture with hydroponics in a symbiotic environment in which plants are fed with the aquatic animals' excreta or wastes.
<b>Compost</b>	Soil conditioner, fertilizer, natural pesticide, a decomposed organic matter which is rich in nutrients.
<b>Floriculture</b>	Production of ornamental plants.
<b>Green manure</b>	Undecomposed green material derived mostly from leguminous plants.
<b>Hydroponics</b>	Soil less growing system in which plants grow in water.
<b>Mariculture</b>	Culture of fishes and other aquatic organism in marine water near the sea coast.
<b>Nectar</b>	Sweet viscous secretion secreted by the flower of plants.
<b>Olericulture</b>	Production of vegetables.
<b>Pisciculture</b>	Culture and rearing of fishes under controlled conditions.
<b>Polyculture</b>	Culture of more than one species of fish in a pond.
<b>Pomology</b>	Production of fruits.
<b>Vermicompost</b>	Vermicompost is the excreta of earthworm.
<b>Vermicomposting</b>	Earthworms degrade organic waste materials into useful product which can be used as a nutrient rich fertilizer.
<b>Vermiculture</b>	Artificial rearing or cultivation of earthworms for the production of vermicompost.



## TEXTBOOK EXERCISES



### I. Choose the correct answer.

- The production and management of fish is called
  - Pisciculture
  - Sericulture
  - Aquaculture
  - Monoculture
- Which one of the following is not an exotic breed of cow?
  - Jersey
  - Holstein-Friesian
  - Sahiwal
  - Brown Swiss
- Which one of the following is an Italian species of honey bee?
  - Apis mellifera*
  - Apis dorsata*
  - Apis florea*
  - Apis cerana*
- Which one of the following is not an Indian major carp?
  - Rohu
  - Catla
  - Mrigal
  - Singhara
- Drones in the honey bee colony are formed from
  - unfertilized egg
  - fertilized egg
  - parthenogenesis
  - both b and c
- Which of the following is an high milk yielding variety of cow?
  - Holstein- Friesian
  - Dorset
  - Sahiwal
  - Red Sindhi
- Which Indian variety of honey bee is commonly used for apiculture?
  - Apis dorsata*
  - Apis florea*
  - Apis mellifera*
  - Apis indica*
- \_\_\_\_\_ is the method of growing plants without soil.
  - Horticulture
  - Hydroponics
  - Pomology
  - None of these.

- The symbiotic association of fungi and vascular plants is
  - Lichen
  - Rhizobium*
  - Mycorrhizae
  - Azotobacter*
- The plant body of mushroom is
  - Spawn
  - Mycelium
  - Leaf
  - All of these

### II. Fill in the blanks.

- Quinine drug is obtained from \_\_\_\_\_.
- Carica papaya* leaf can cure \_\_\_\_\_ disease.
- Vermicompost is a type of soil made by \_\_\_\_\_ and microorganisms.
- \_\_\_\_\_ refers to the culture of prawns, pearl and edible oysters.
- The largest member in a honey bee hive is the \_\_\_\_\_.
- \_\_\_\_\_ is a preservative in honey.
- \_\_\_\_\_ is the method of culturing different variety of fish in a water body.

### III. Say true or false. If false, correct the statement.

- Mycorrhiza is an algae.
- Milch animals are used in agriculture and transport.
- Apis florea* is a rock bee.
- Ongole is an exotic breed of cattle.
- Sheep manure contains high nutrients than farm yard manure.

#### IV. Differentiate the following.

- Exotic breed and Indigenous breed
- Pollen and Nectar
- Shrimp and Prawn
- Farmyard manure and Sheep manure

#### V. Match the following.

Column A	Column B
Lobsters	Marine fish
Catla	Pearl
Sea bass	Shell fish
Oysters	Paddy
Pokkali	Fin fish
<i>Pleurotus sps</i>	Psoriasis
Sarpagandha	Oyster mushroom
Olericulture	Reserpine
<i>Wrightia tinctoria</i>	Vegetable farming

#### VI. Answer briefly.

- What are secondary metabolites?
- What are the types of vegetable garden?
- Mention any two mushroom preservation methods.
- Enumerate the advantages of vermicompost over chemical fertiliser.
- What are the species of earthworm used for vermiculture?
- List the medicinal importance of honey.

#### VII. Answer in detail.

- Enumerate the advantage of hydroponics.
- Define Mushroom culture. Explain the mushroom cultivation methods.

- What are the sources of organic resources for vermicomposting?
- Give an account of different types of fish ponds used for rearing fishes.
- Classify the different breeds of the cattle with suitable examples.

#### VIII. Higher Order Thinking Skills.

- Biomanuring plays an important role in agriculture. Justify
- Each bee hive consists of hexagonal cells. Name the material in which the cell is formed and mention the significance of the hexagonal cells.



#### REFERENCE BOOKS

- Jawaid Ahsan and Subhas Prasad Sinha A Hand Book on Economic Zoology, S.Chand and Company , New Delhi
- Sharma O.P. Economic Botany Tata Mc Graw Publishing Co Ltd
- Ismail, S.A. The Earthworm Book, Other India Press, Goa



#### INTERNET RESOURCES

- [http:// www.biology.online.org](http://www.biology.online.org)  
[www.agritech.tnau.ac.in](http://www.agritech.tnau.ac.in)  
[www.fisheries.tn.gov.in](http://www.fisheries.tn.gov.in)  
[www.tnhorticulture.tn.gov.in](http://www.tnhorticulture.tn.gov.in)  
[www.biology discussion.com](http://www.biology discussion.com)  
[www.nios.ac.in.textbook.com](http://www.nios.ac.in.textbook.com)

# Concept Map

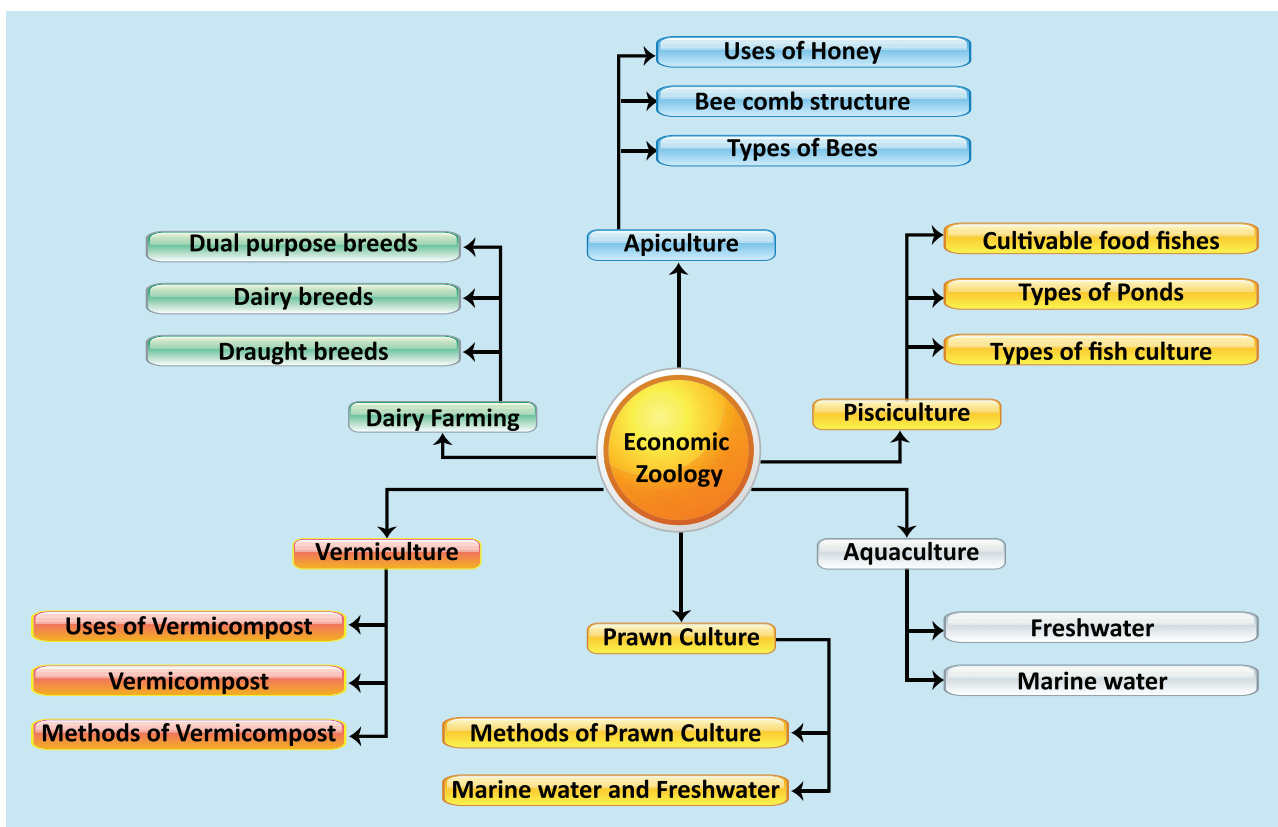
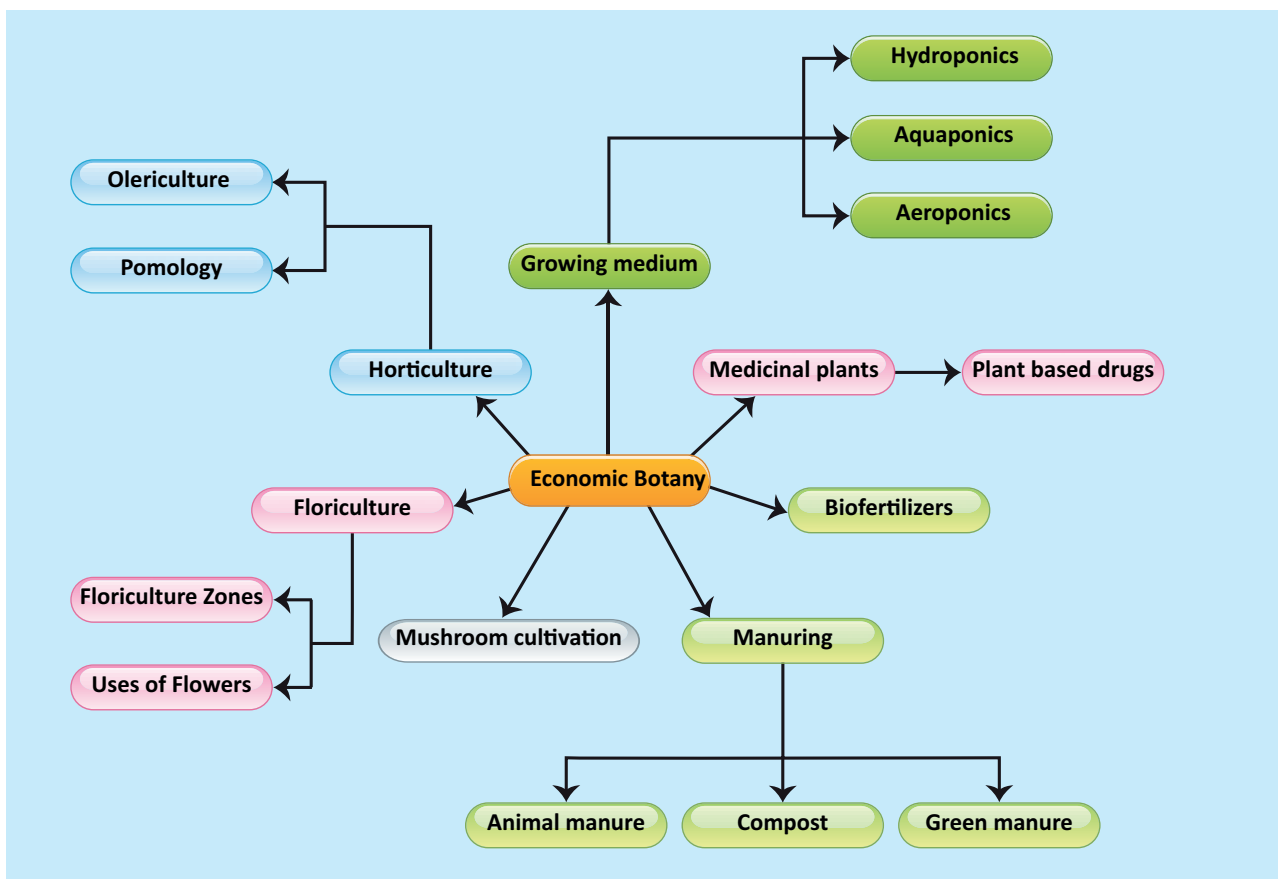

## Learning Objectives

After completing this lesson, students will be able to

- relate different aspects of environmental science.
- describe biogeochemical cycles.
- analyse the impacts of human activities on water cycle, nitrogen cycle and carbon cycle.
- correlate the adaptations of plants with the habitat.
- explain the adaptations of bat and earthworm.
- explain recycling of water its methods and importance .
- discuss the importance of water conservation and water recycling methods.



## Introduction

*“Nature has the power to refresh and renew”*  
- Helen Keller

Elements of nature continuously undergo changes and transformations. Environmental protection provides holistic knowledge about natural processes, effects of human intervention and solutions to overcome environmental problems. Environmental issues such as pollution, global warming, ozone layer depletion, acid rain, deforestation, landslide, drought and desertification have gained major focus across the world. Natural resources are recycled over and over again on earth for continued availability. At the same time, it also reminds us of our responsibility to reduce and restrain our activities that will affect the natural processes.

Living organisms adjust themselves according to their habitat and changes in the ecosystem. All living organisms develop certain morphological, anatomical, physiological and reproductive adaptations which help them to survive better and to withstand environmental conditions.

This lesson deals with bio-geo-chemical cycles, adaptations by the plants and animals, water conservation and recycling of water.

### 24.1 Biogeochemical Cycles (bio – life; geo – earth)

Biosphere is the part of the earth where life exists. All resources of biosphere can be grouped into two major categories namely:

- (i) Biotic or living factors which include plants, animals and all other living organisms.
- (ii) Abiotic or non-living factors which include all factors like temperature, pressure, water, soil, air and sunlight which affect the ability of organisms to survive and reproduce.

There is a constant interaction between biotic and abiotic components in the biosphere and that makes the biosphere a dynamic and stable system. Cyclic flow of nutrients between non-living and living factors of the environment are termed as bio-geo-chemical cycles. Some of the important biogeochemical cycles are:

1. Water cycle
2. Nitrogen cycle
3. Carbon cycle

### 24.1.1 Water Cycle

Water cycle or hydrological cycle is the continuous movement of water on earth. In this process, water moves from one reservoir to another by processes such as evaporation, sublimation, transpiration, condensation, precipitation, surface runoff and infiltration, during which water converts itself to various forms like liquid, solid and vapour (Fig. 24.1).

**Evaporation:** Evaporation is a type of vaporization, where liquid is converted to gas before reaching its boiling point. Water evaporates from the surface of the earth and water bodies such as the oceans, seas, lakes, ponds and rivers.

**Sublimation:** Sublimation is conversion of solid to gas, without passing through the intermediate liquid phase. Ice sheets and ice caps from north and south poles, and icecaps on mountains, get converted into water vapour directly, without converting into liquid.

**Transpiration:** Transpiration is the process by which plants release water vapour into the atmosphere through stomata in leaves and stems.

**Condensation:** Condensation is the changing of gas phase into liquid phase and is the reverse of

vaporisation. At higher altitudes, the temperature is low. The water vapour present there condenses to form very tiny particles of water droplets. These particles come close together to form clouds and fog.

**Precipitation:** Due to change in wind or temperature, clouds combine to make bigger droplets, and pour down as precipitation(rain). Precipitation includes drizzle, rain, snow and hail.

**Run off :** As the water pours down, it runs over the surface of earth. Runoff water combines to form channels, rivers, lakes and ends up into seas and oceans.

**Infiltration:** Some of the precipitated water moves deep into the soil. Then it moves down and increases the ground water level.

**Percolation:** Some of the precipitated water flows through soil and porous or fractured rock.

Infiltration and percolation are two related but different processes describing the movement of water through soil.

#### Human impacts on water cycle

Major human activities affecting the water cycle on land are urbanisation, dumping of plastic waste on land and into water, polluting water bodies and deforestation.

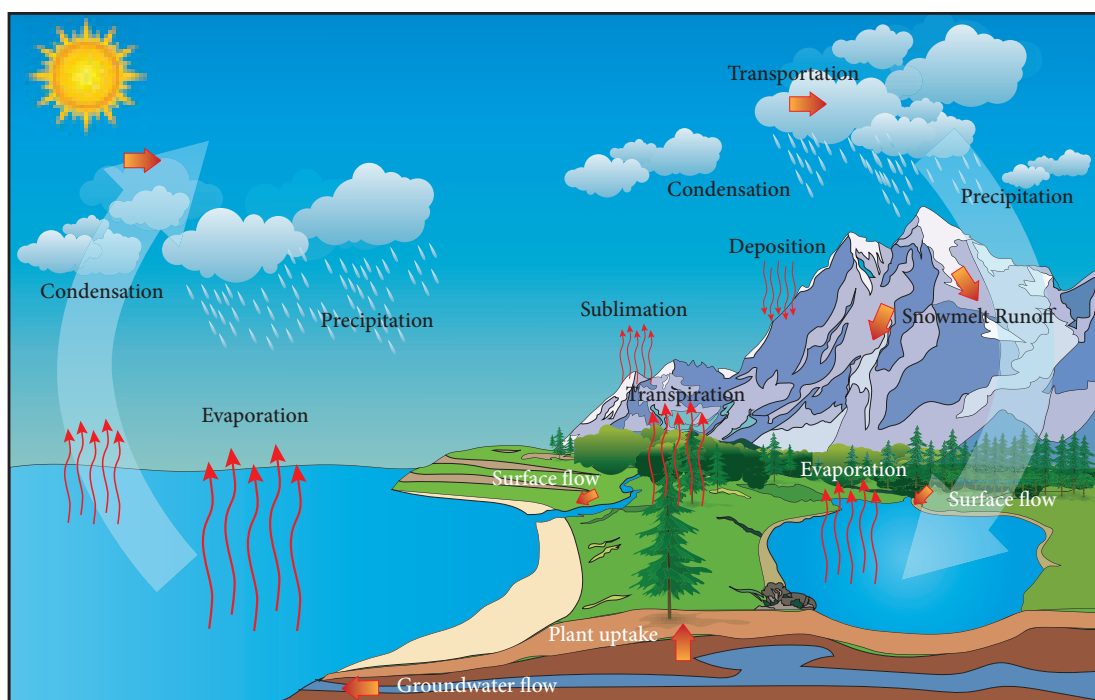

Figure 24.1 Water cycle

## Activity 1

### Create your own water cycle

Take a small container and place it in the middle of the large bowl. Fill water in the large container and cover it with plastic wrap. Fasten the plastic wrap around the rim of the large container with the rubber band. Place a stone on the top of the plastic wrap. Keep this under sun for few hours.

Record your observation.

## 24.1.2 Nitrogen Cycle

Nitrogen is the important nutrient needed for the survival of all living organisms. It is an essential component of proteins, DNA and chlorophyll. Atmosphere is a rich source of nitrogen and contains about 78% nitrogen. Plants and animals cannot utilize atmospheric nitrogen. They can use it only if it is in the form of ammonia, amino acids or nitrates.

Processes involved in nitrogen cycle are explained below.

**Nitrogen fixation :** Nitrogen fixation is the conversion of atmospheric nitrogen, which is in inert form, to reactive compounds available to living organisms. This conversion is done by a number of bacteria and **blue green algae** (Cyanobacteria). **Leguminous plants** like pea and beans have a symbiotic relationship with nitrogen fixing bacteria *Rhizobium*. *Rhizobium* occur in the root nodules of leguminous plants and fixes nitrogenous compounds.

**Nitrogen assimilation:** Plants absorb nitrate ions and use them for making organic matter like proteins and nucleic acids. Herbivorous animals convert plant proteins into animal proteins. Carnivorous animals synthesize proteins from their food.

**Ammonification:** The process of decomposition of nitrogenous waste by putrefying bacteria and fungi into ammonium compounds is called ammonification. Animal proteins are excreted in the form of urea, uric acid or ammonia. The putrefying bacteria and fungi decompose these animal proteins, dead animals and plants into ammonium compounds.

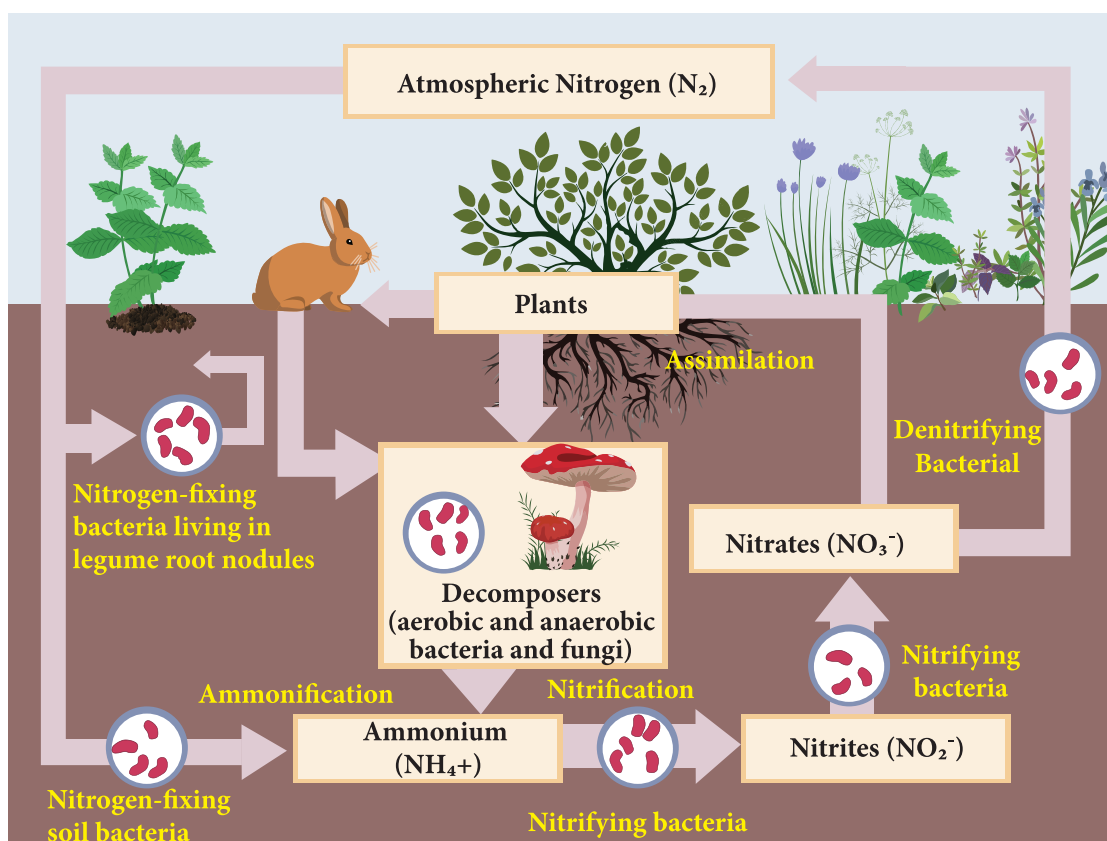

Figure 24.2 Nitrogen cycle



**Nitrification:** The ammonium compounds formed by ammonification process are oxidised to soluble nitrates. This process of nitrate formation is known as nitrification. The bacteria responsible for nitrification are called as nitrifying bacteria.

**Table 24.1** Microorganisms involved in nitrogen cycle

Role played in nitrogen cycle	Name of the microorganisms
Nitrogen fixation	<i>Azotobacter</i> (in soil) <i>Rhizobium</i> (in root nodules) Blue green algae- <i>Nostoc</i>
Ammonification	Putrefying bacteria, Fungi
Nitrification	Nitrifying bacteria i. <i>Nitrosomonas</i> ii. <i>Nitrobacter</i>
Denitrification	Denitrifying bacteria <i>Pseudomonas</i>

**Denitrification:** Free living soil bacteria such as *Pseudomonas sp.* reduce nitrate ions of soil into gaseous nitrogen which enters the atmosphere.

### Human impacts on nitrogen cycle

Burning fossil fuels, application of nitrogen-based fertilizers and other activities can increase the amount of biologically available nitrogen in an ecosystem. Nitrogen applied to agricultural fields enters rivers and marine systems. It alters the biodiversity, changes the food web structure and destroys the general habitat.

### 24.1.3 Carbon Cycle

Carbon occurs in various forms on earth. Charcoal, diamond and graphite are elemental forms of carbon. Combined forms of carbon include carbon monoxide, carbon dioxide and carbonate salts. All living organisms are made up of carbon containing molecules like proteins and nucleic acids. The atmospheric carbon dioxide enters into the plants through the process of photosynthesis to form carbohydrates. From plants, it is passed on to herbivores and carnivores. During respiration, plants and

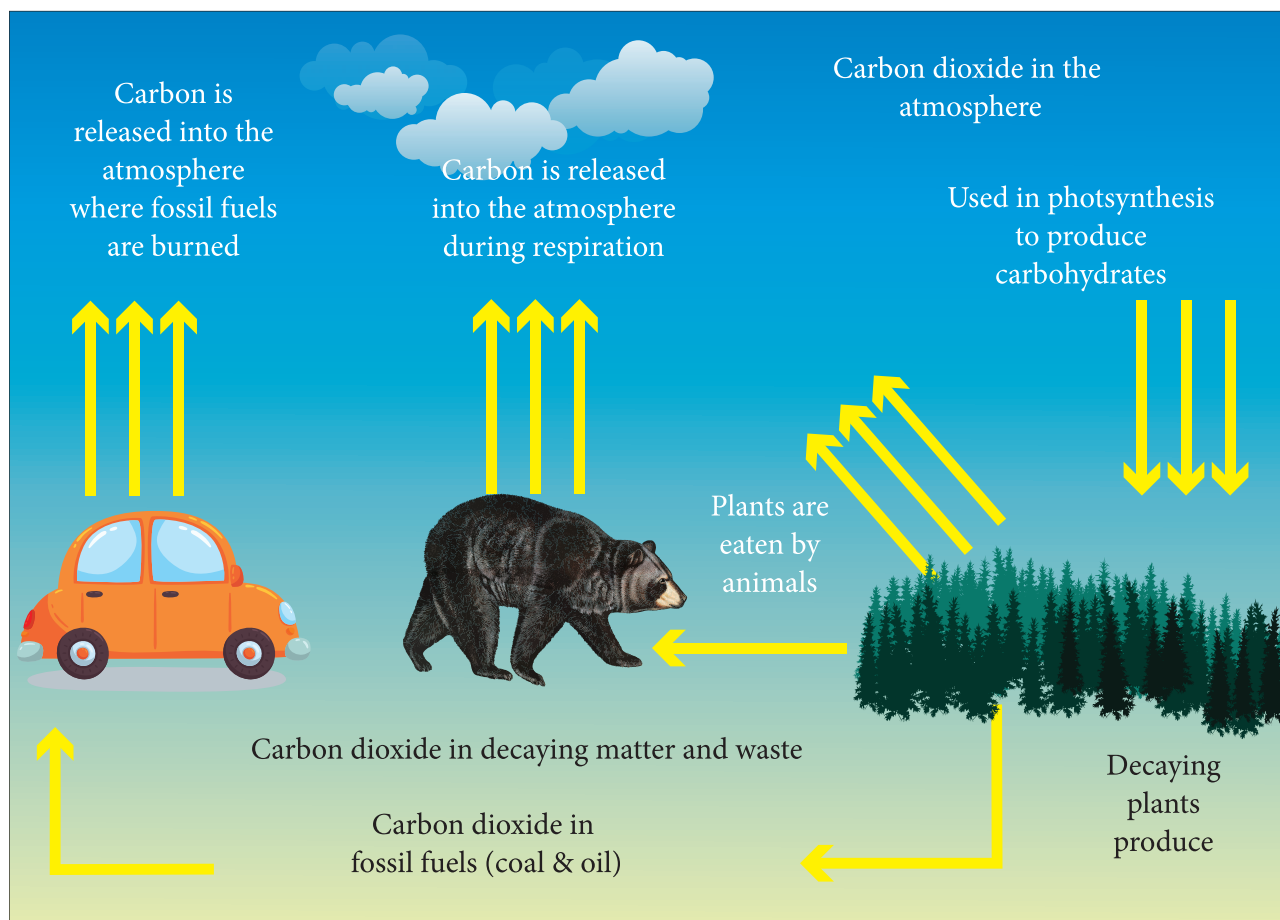

**Figure 24.3** Carbon cycle

animals release carbon into atmosphere in the form of carbon dioxide. Carbon dioxide is also returned to the atmosphere through decomposition of dead organic matter, burning fossil fuels and volcanic activities.

### Human impacts on carbon cycle

More carbon moves into the atmosphere due to burning of fossil fuels and deforestation. Most of the carbon in atmosphere is in the form of carbon dioxide. Carbon dioxide is a greenhouse gas. By increasing the amount of carbon dioxide, earth becomes warmer. This leads to greenhouse effect and global warming.

## 24.2 Adaptations of Plants

Any feature of an organism or its part that enables it to exist under conditions of its habitat is called adaptation. On the basis of water availability, plants have been classified as:

- (i) Hydrophytes
- (ii) Xerophytes
- (iii) Mesophytes



### 24.2.1 Hydrophytes

Plants growing in or near water are called hydrophytes. Hydrophytes may be free floating or submerged plants living in lakes, ponds, shallow water, marshy lands and marine habitat. Hydrophytes face certain challenges in their habitat. They are:

- (i) Availability of more water than needed.
- (ii) Water current may damage the plant body.
- (iii) Water levels may change regularly.
- (iv) Maintain buoyancy in water.

#### Adaptations of hydrophytes

1. Roots are poorly developed as in *Hydrilla* or absent as in *Wolffia*.
2. Plant body is greatly reduced as in *Lemna*.
3. Submerged leaves are narrow or finely divided. e.g. *Hydrilla*.



*Hydrilla*

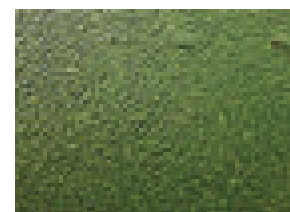

*Wolffia*

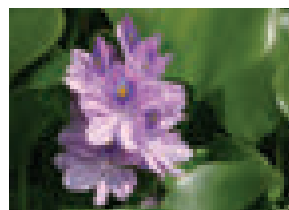

*Eichhornia*



*Lemna*

**Figure 24.4** Hydrophytes

4. Floating leaves have long leaf stalks to enable the leaves move up and down in response to changes in water level. e.g. Lotus.
5. Air chambers provide buoyancy and mechanical support to plants as in *Eichhornia* (swollen and spongy petiole).

### 24.2.2 Xerophytes

Plants that grow in dry habitat are called xerophytes. These plants develop special structural and physiological characteristics to meet the following conditions:

- (i) To absorb as much water as they can get from the surroundings.
- (ii) To retain water in their organs for very long time.
- (iii) To reduce the transpiration rate.
- (iv) To reduce consumption of water.

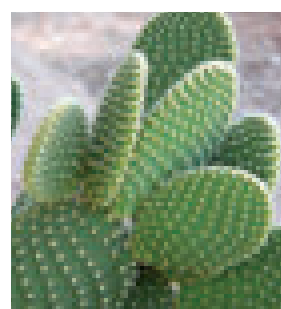

*Opuntia*

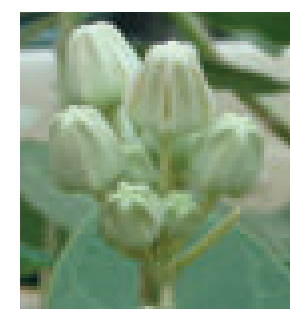

*Calotropis*

**Figure 24.5** Xerophytes



### Adaptations of xerophytes

1. They have well developed roots. Roots grow very deep and reach the layers where water is available as in *Calotropis*.
2. They store water in succulent water storing parenchymatous tissues. e.g. *Opuntia*, *Aloe vera*.
3. They have small sized leaves with waxy coating. e.g. *Acacia*. In some plants, leaves are modified into spines. e.g. *Opuntia*.
4. Some of the xerophytes complete their life cycle within a very short period when sufficient moisture is available

### 24.2.3 Mesophytes

Mesophytes are common land plants which grow in situations that are neither too wet nor too dry. They do not need any extreme adaptations.

### Adaptations of mesophytes

1. The roots of mesophytes are well developed and are provided with root caps.
2. The stem is generally straight and branched.
3. The leaves are generally broad and thin.
4. The presence of waxy cuticle in leaves traps the moisture and lessens water loss.
5. Leaves have stomata which close in extreme heat and wind to prevent transpiration.

## 24.3 Adaptations of Animals

Animals can adapt themselves according to their habitat. Temperature and light are forms of energy which influence various stages of life activities such as growth, metabolism, reproduction, movement, distribution and behaviour. Animals develop special features or behaviour patterns to escape from extreme conditions of temperature and light. In this context, let us study about the adaptive features of bat and earthworm.

### 24.3.1 Adaptations of Bat

Bats are the only mammals that can fly. Mostly, bats live in caves. Apart from caves, bats also live in trees, hollowed logs and rock

crevices. They are extremely important to humans as they reduce insect population and help to pollinate plants. Adaptations of bat in relation to their habitat are explained below.

### Nocturnality

Bats are active at night. This is a useful adaptation for them, as flight requires a lot of energy during day. Their thin, black wing membrane (Patagium) may cause excessive heat absorption during the day. This may lead to dehydration.

### Flight adaptation

Forelimbs are modified serve wings. Tail supports and controls movements during flight. Muscles are well developed and highly powerful and achieve in beating of wings. Tendons of hind limbs provide a tight grasp when the animals are suspended upside down at rest.

### Hibernation

Hibernation is a state of inactivity in which the body temperature drops with a lowered metabolic rate during winter. Bats are warm blooded animals but unlike other mammals, they let their internal temperature reduce when they are resting. They go to a state of decreased activity to conserve energy.

### Echolocation

Bats use a remarkable high-frequency system called echolocation. Bats give out high-frequency sounds (ultrasonic sounds). These sounds are reflected back from its prey and perceived by the ear. Bats use these echoes to locate and identify the prey.



Bats emit ultrasonic pulses of sound at objects and listen for echoes.

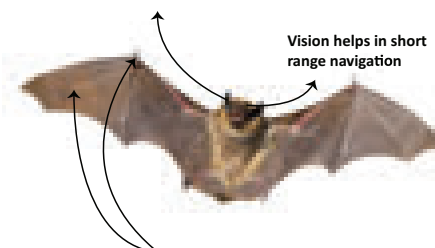

Bats wings are a thin skin membrane stretched between extra long finger bones.

**Figure 24.6** Bats



### 24.3.2 Adaptations of Earthworm

It is commonly found in soil, feeding on live and dead organic matter. Earthworm plays a vital role in maintaining soil fertility. It facilitates aeration, water infiltration and producing organic matter to increase crop growth. Some of the adaptations of earthworm are:

#### Stream-lined body

The earthworm has a cylindrical, elongated and segmented body. This helps them to live in narrow burrows underground and for easy penetration into the soil.

#### Skin

Mucus covers the skin which does not allow soil particles to stick to it. Moist skin helps in oxygenation of blood.

#### Burrowing

Its body is flexible having circular and longitudinal muscles which help in movement and subsoil burrowing. Each segment on the lower surface of the body has number of **setae**. They help the earthworm to move through the soil and provide anchor in the burrows.

#### Aestivation

When the soil becomes too hot or dry, earthworms become inactive and undergo a process called aestivation. Earthworm moves deeper into the soil. It secretes mucus and lowers their metabolic rate in order to reduce water loss. They remain dormant until conditions become favourable. They come out of their burrow during rainy season.



Earthworms are referred as '*Farmer's friend*'. After digesting organic matter, earthworms excrete a nutrient-rich waste product called castings which is used as Vermicompost.

#### Nocturnality

Earthworms are sensitive to light. It has no eyes but can sense light through light sensitive cells (**Photoreceptors**) present in their skin. They react negatively to bright light

(Photophobic). It remains in its burrow during the day to avoid light.

## 24.4 Water Conservation

Water conservation is the preservation, control and management of water resources. It also includes activities to protect the hydrosphere and to meet the current and future human demand.

### 24.4.1 Importance of Water Conservation

- It creates more efficient use of the water resources.
- It ensures that we have enough usable water.
- It helps in decreasing water pollution.
- It helps in increasing energy saving.

### 24.4.2 Water Conservation Measures

#### Industrial conservation

Water conservation measures that can be taken by industries are:

- using dry cooling systems.
- if water is used as cooling agent, reusing the water for irrigation or other purposes.

#### Agricultural conservation

Agricultural water is often lost due to leaks in canals, run off and evaporation. Some of the water conserving methods are:

- using lined or covered canals that reduce loss of water and evaporation.
- using improved techniques such as sprinklers and drip irrigation.
- encouraging the development of crops that require less water and are drought resistant.
- mulching of soil in vegetable cultivation and in horticulture.



World Water Day on 22<sup>nd</sup> March every year, is about focusing attention on the importance of water.

## Domestic conservation

All of us have the responsibility to conserve water. We can conserve water by the following activities:

- Using a bucket of water to take bath than taking a shower.
- Using low flow taps.
- Using recycled water for lawns.
- Repairing the leaks in the taps.
- Recycling or reusing water wherever it is possible.

### 24.4.3 Strategies adopted to conserve Water

- (i) Rain water harvesting.
- (ii) Improved irrigation techniques.
- (iii) Active use of traditional water harvesting structures.
- (iv) Minimising domestic water consumption.
- (v) Awareness on water conservation.
- (vi) Construction of farm ponds.
- (vii) Recycling of water.

## 24.5 Farm Ponds

Farm ponds are used as one of the strategies to support water conservation. Much of the rainfall runs off the ground. The run off not only causes loss of water but also washes away precious top soil. Farm ponds help the farmers to store water and to use it for irrigation.

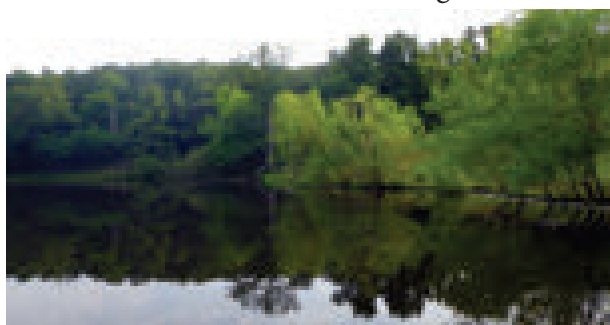

Figure 24.7 Farm pond

### 24.5.1 Layout of a Farm Pond

Farm pond is a dugout structure with definite shape and size. They have proper inlet and outlet structures for collecting the surface runoff flowing from the farm area. The stored water is used for irrigation.

### 24.5.2 Advantages of Farm Ponds

The advantages of farm ponds are:

- They provide water to growing crops, without waiting for rainfall.
- They provide water for irrigation, even when there is no rain.
- They reduce soil erosion.
- They recharge ground water.
- They improve drainage.
- The excavated soil can be used to enrich soil in fields and levelling lands.
- They promote fish rearing.
- They provide water for domestic purposes and livestock.

## 24.6 Water Recycling

Water recycling, apart from rain water harvesting, is also one of the key strategies to conserve water. Water recycling is reusing treated wastewater for beneficial purposes such as agricultural and landscape irrigation, industrial processes, flushing in toilets and ground water recharge.

### 24.6.1 Wastewater Recycling Stages

Conventional waste water treatment consists of a combination of physical, chemical and biological processes which remove solids, organic matter and nutrients from waste water. The waste water treatment involves the following stages:

#### Primary treatment

Primary treatment involves temporary holding of the wastewater in a tank. The heavy solids get settled at the bottom while oil, grease and lighter solids float over the surface. The settled and floating materials are removed. The remaining liquid undergoes secondary treatment.

#### Secondary treatment

Secondary treatment is used to remove the biodegradable dissolved organic matter. This is performed in the presence of oxygen by aerobic microorganisms (Biological oxidation). The microorganisms must be separated from treated

water waste by sedimentation. After separating the sediments of biological solids, the remaining liquid is discharged for tertiary treatment.

### Tertiary treatment

Tertiary or advanced treatment is the final step of sewage treatment. It involves removal of inorganic constituents such as nitrogen, phosphorus and microorganisms. The fine colloidal particles in the sewage water are precipitated by adding chemical coagulants like alum or ferric sulphate.

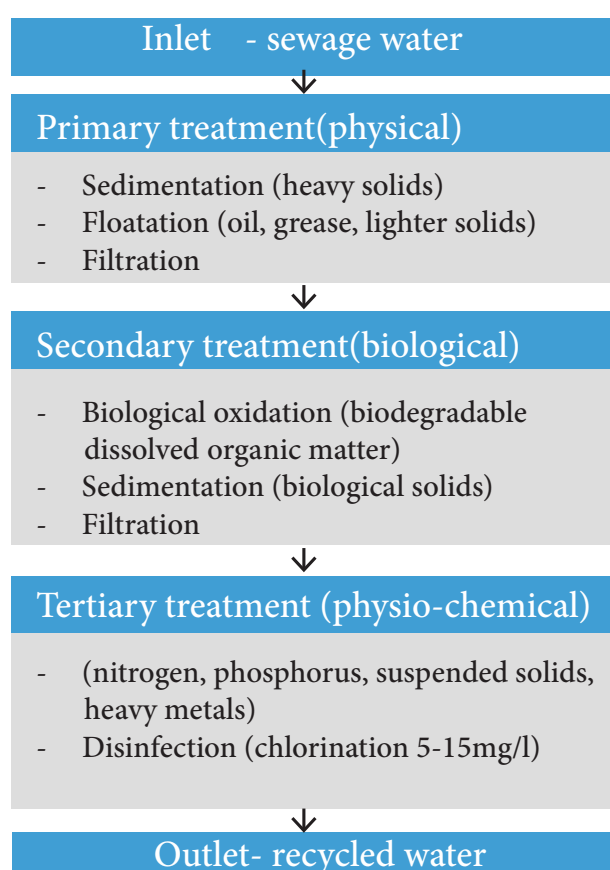

### 24.6.2 Uses of Recycled Water

- Agriculture
- Landscape
- Public parks
- Cooling water for power plants and oil refineries
- Toilet flushing
- Dust control
- Construction activities

## 24.7 IUCN (International Union for Conservation of Nature and Natural Resources)

IUCN is an international organization working in the field of nature conservation and sustainable use of natural resources. IUCN is the global authority on the status of the natural world and the measures needed to safeguard it.

### Vision of IUCN

The vision of IUCN is 'A just world that values and conserves nature'.

### Mission of IUCN

The mission of IUCN is to influence, encourage and assist societies throughout the world to conserve the integrity and diversity of nature and to ensure that any use of natural resources is equitable and ecologically sustainable.

The organization is best known to the wider public for compiling and publishing the IUCN red list of threatened species, which assesses the conservation status of species worldwide.

India, a mega diverse country with only 2.4 % of world's land area, accounts for 7-8% of all recorded species. It includes over 45,000 species

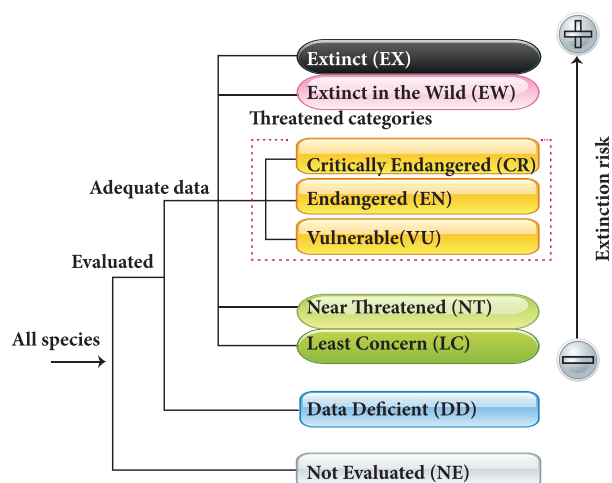

Figure 24.8 Red list categories of IUCN

of plants and 91,000 species of animals. The country's diverse physical features and climatic conditions have resulted in a variety of ecosystems such as forests, wetlands, grasslands, desert, coastal and marine ecosystems. Four of 34 globally identified biodiversity hotspots are found in India. They are:

- The Himalayas
- The Western ghats
- The North-East
- The Nicobar islands

India became state member of IUCN in 1969, through the Ministry of Environment, Forest and Climate change (MoEFCC).

**DO YOU KNOW?** IUCN was founded on 5<sup>th</sup> October 1948 at Gland, Switzerland.



CR: Himalayan brown/red bear



EN: Red Panda

**Figure 24.9** Animals in Red List

### Points to Remember

- ❖ Cyclic flow of nutrients between non-living environment and living organisms are termed as biogeochemical cycles.
- ❖ The ammonium compounds formed by ammonification process is oxidised to soluble nitrates. The process of nitrate formation is known as nitrification.
- ❖ Hydrophytes may be free floating or submerged plants living in lakes, ponds, shallow water, marshy lands and marine habitat.
- ❖ Plants that grow in dry habitat are called xerophytes.
- ❖ Mesophytes are common land plants which grow in situations that are neither too wet nor too dry.
- ❖ Animals develop special features or behaviour patterns to escape from the extreme conditions of temperature and light.
- ❖ Farm pond is a dugout structure with definite shape and size for collecting the surface runoff flowing from the area around the farm.
- ❖ Water recycling is reusing treated wastewater for beneficial purposes
- ❖ IUCN is the global authority on the status of the natural world and the measures needed to safeguard it.

## A-Z GLOSSARY

<b>Aestivation</b>	State of inactivity and a lowered metabolic rate in animals, during summer.
<b>Assimilation</b>	Conversion of nutrients into usable form that is incorporated into the tissues and organs.
<b>Buoyancy</b>	Capacity to remain afloat in liquid or gas.
<b>Echo location</b>	Use of sound waves and their echoes to determine the location of objects.
<b>Hibernation</b>	State of inactivity and a lowered metabolic rate in animals, during winter.
<b>Infiltration</b>	Process by which water on the ground surface enters the soil.
<b>Precipitation</b>	Product of condensation of atmospheric water vapour that falls on earth.
<b>Setae</b>	Hair-like locomotory structure, present in each segment of an earthworm.
<b>Stomata</b>	Minute pores in the epidermis of leaves which facilitate gaseous exchange and transpiration.
<b>Sublimation</b>	Conversion of solid state into vapour state without going through a liquid state.



## TEXTBOOK EXERCISES



### I. Choose the correct answer.

- All the factors of biosphere which affect the ability of organisms to survive and reproduce are called as \_\_\_\_\_.
  - biological factors
  - abiotic factors
  - biotic factors
  - physical factors
- The ice sheets from the north and south poles and the icecaps on the mountains, get converted into water vapour through the process of \_\_\_\_\_.
  - evaporation
  - condensation
  - sublimation
  - infiltration
- The atmospheric carbon dioxide enters into the plants through the process of \_\_\_\_\_.
  - photosynthesis
  - assimilation
  - respiration
  - decomposition
- Increased amount of \_\_\_\_\_ in the atmosphere, results in greenhouse effect and global warming
  - carbon monoxide
  - sulphur dioxide
  - nitrogen dioxide
  - carbon dioxide

### II. Match the following.

Microorganism	Role Played
<i>Nitrosomonas</i>	Nitrogen fixation
<i>Azotobacter</i>	Ammonification
<i>Pseudomonas species</i>	Nitrification
Putrefying bacteria	Denitrification

### III. State whether true or false. If false, correct the statement.

- Nitrogen is a greenhouse gas.
- Poorly developed root is an adaptation of mesophytes.
- Bats are the only mammals that can fly.

4. Earthworms use the remarkable high frequency system called echoes.

5. Aestivation is an adaptation to overcome cold condition.

### IV. Give reason for the following.

- Roots grow very deep and reach the layers where water is available. Which type of plants develops the above adaptation? Why?
- Why streamlined bodies and presence of setae is considered as adaptations of earthworm?
- Why is it impossible for all farmers to construct farm ponds in their fields?

### V. Answer briefly.

- What are the two factors of biosphere?
- How do human activities affect nitrogen cycle?
- What is adaptation?
- What are the challenges faced by hydrophytes in their habitat?
- Why is it important to conserve water?
- List some of the ways in which you could save water in your home and school.
- What are the uses of recycled water?
- What is IUCN? What is the vision of IUCN?

### VI. Answer in detail.

- Describe the processes involved in the water cycle.
- Explain carbon cycle with the help of a flow chart.
- List out the adaptations of xerophytes.
- How does a bat adapt itself to its habitat?
- What is water recycling? Explain the conventional wastewater recycling treatment methods.





## REFERENCE BOOKS

1. Shukla R.S and Chandel. P.S. A textbook of Plant Ecology including Ethnobotany and Soil Science.
2. Verma, P.S and Agarwal. V.K. Environmental Biology, S.Chand and Company, New Delhi.
3. Kotpal R.L Zoology- Phylum - Annelida - Rastogi Publications, Meerut.



## INTERNET RESOURCES

- www.freedrinkingwater.com  
 www.nature.com  
 www.sciencefocus.com  
 www.sciencelearn.org  
 www.IUCN.org

## Concept Map

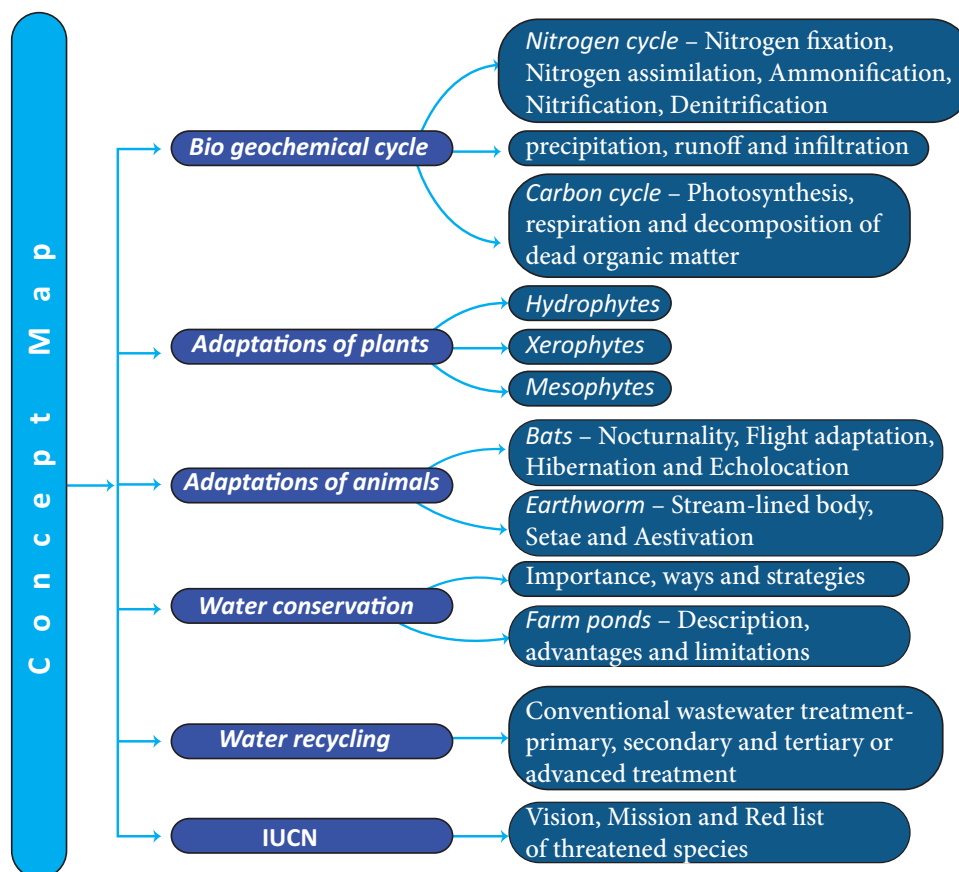

## ICT CORNER

## Environmental Science

### Steps

- Type the given URL to reach “The Carbon Cycle” simulation page.
- Press “Run Decade” button to observe the carbon cycle accumulating every 10 years.
- Select “Curb Emission” from “lesson” tab and adjust the simulation parameters to watch the effect of cycle.
- Select “Feedback Effects” from “lesson” tab and run the cycle and analyze the carbon accumulation result.

### Carbon cycle

URL: <https://www.learner.org/courses/envsci/interactives/carbon/carbon.html>  
 or Scan the QR Code.



B567\_9\_SCI\_EM\_T3

# UNIT 25

## LibreOffice Impress

### Learning Objectives

After the completion of this lesson, students will be able to:

- define presentation.
- create a new presentation.
- insert text box, images, audio and video files.
- insert and delete a slide.
- view a slide show.



### Introduction

LibreOffice Impress is a software that is used to create a presentation with text effect, graphics, sound to make it interesting and effective for the audience. A colourful presentation containing text, photos, picture, sound and animation will amaze the viewers and make them more interested to listen to the presentation. Animation is the process of creating movement for an object. It is a user friendly application software. To start LibreOffice Impress, we can follow the steps given below:

1. Click the **Start** button.
2. Click **All Programs**.
3. Click **LibreOffice Impress**
4. Click **LibreOffice Impress** option.

### 25.1 Presentation

A presentation is a structured delivery of information. It is a systematic display of information along with graphics, movies, sound, etc. All these are displayed together on the screen.

#### 25.1.1 Create a Blank Presentation

To create a Blank presentation, follow the given steps:

1. Click the LibreOffice Impress
2. Click the New option from the File menu.
3. Click Presentation option from the left pane.
4. Click Blank Presentation option.

**LIBREOFFICE IMPRESS**



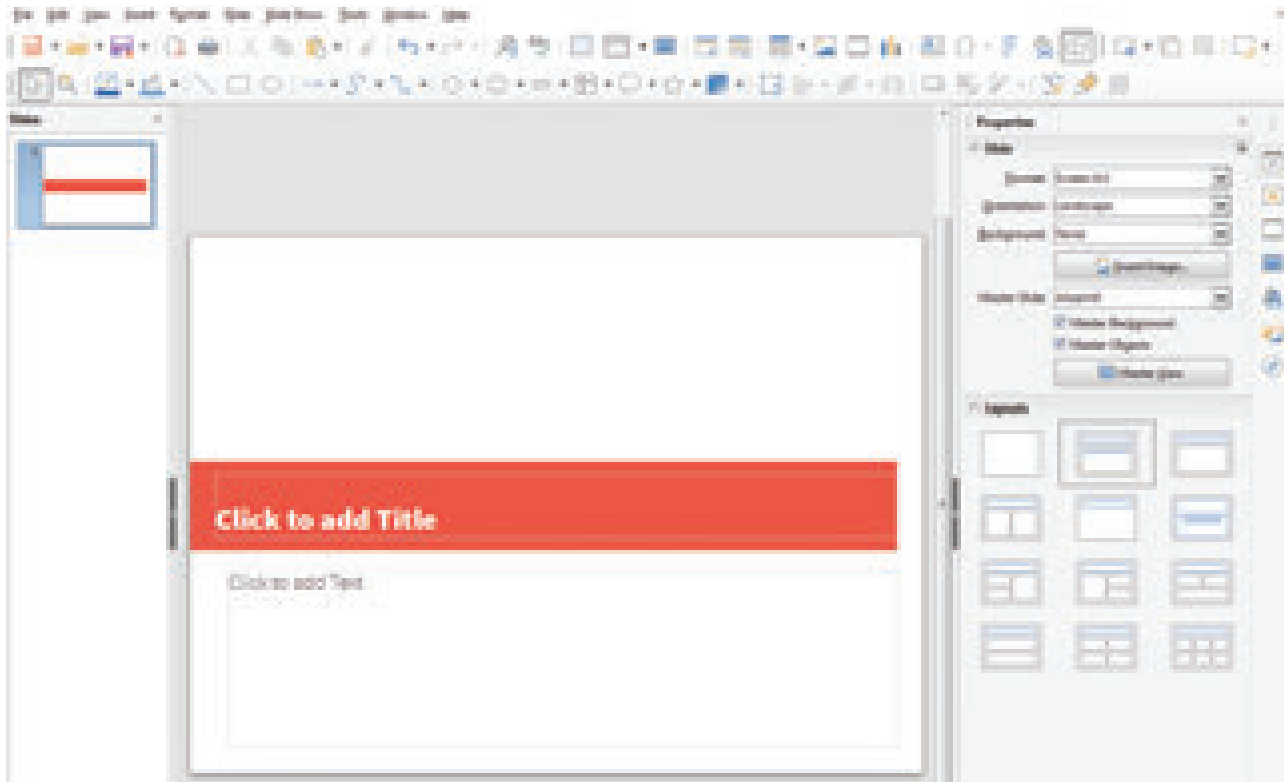

### 25.1.2 Working in a Slide

You know that a LibreOffice Impress presentation is a combination of many slides. You can create additional slides. These slides, when displayed in sequence, form a presentation. So, in order to prepare a presentation, we have to prepare its slides first.

When you create a Blank Presentation, a slide appears on the screen with two placeholders.

1. Click inside a placeholder to enter text. The cursor appears.
2. Type the text. After you finish typing the text, click outside the placeholder.

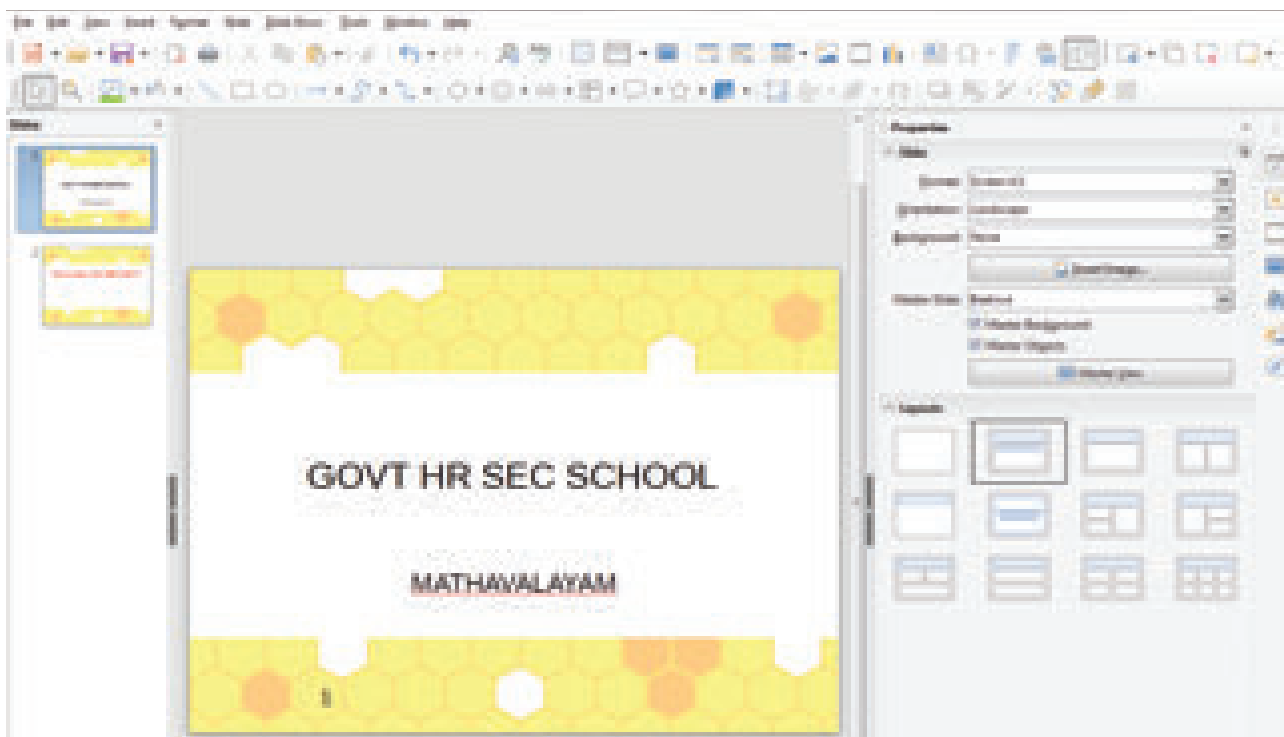

### 25.1.3 Inserting New Slide

To insert a new slide in a presentation, follow the given steps:

1. Click the Slide Menu.
2. Click New Slide from slides menu.
3. Choose the layout you want. For example, Blank, the new slide is inserted. Similarly, you can add many slides in a presentation.

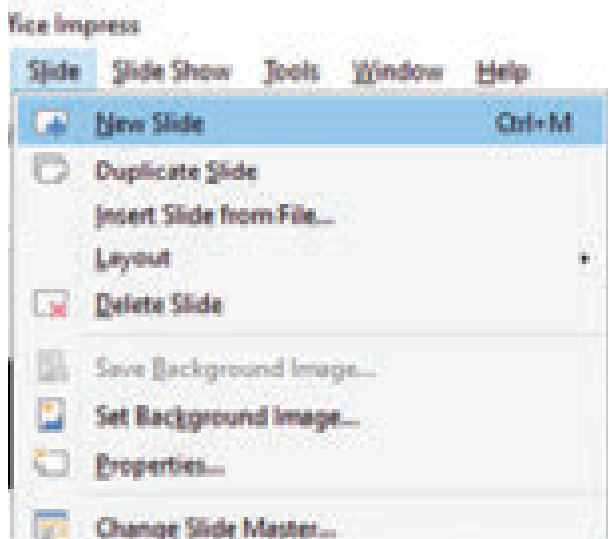

### 25.1.4 Inserting pictures

To Insert a Picture in a slide, choose insert ->Image or click the Insert image icon from the Standard Toolbar.

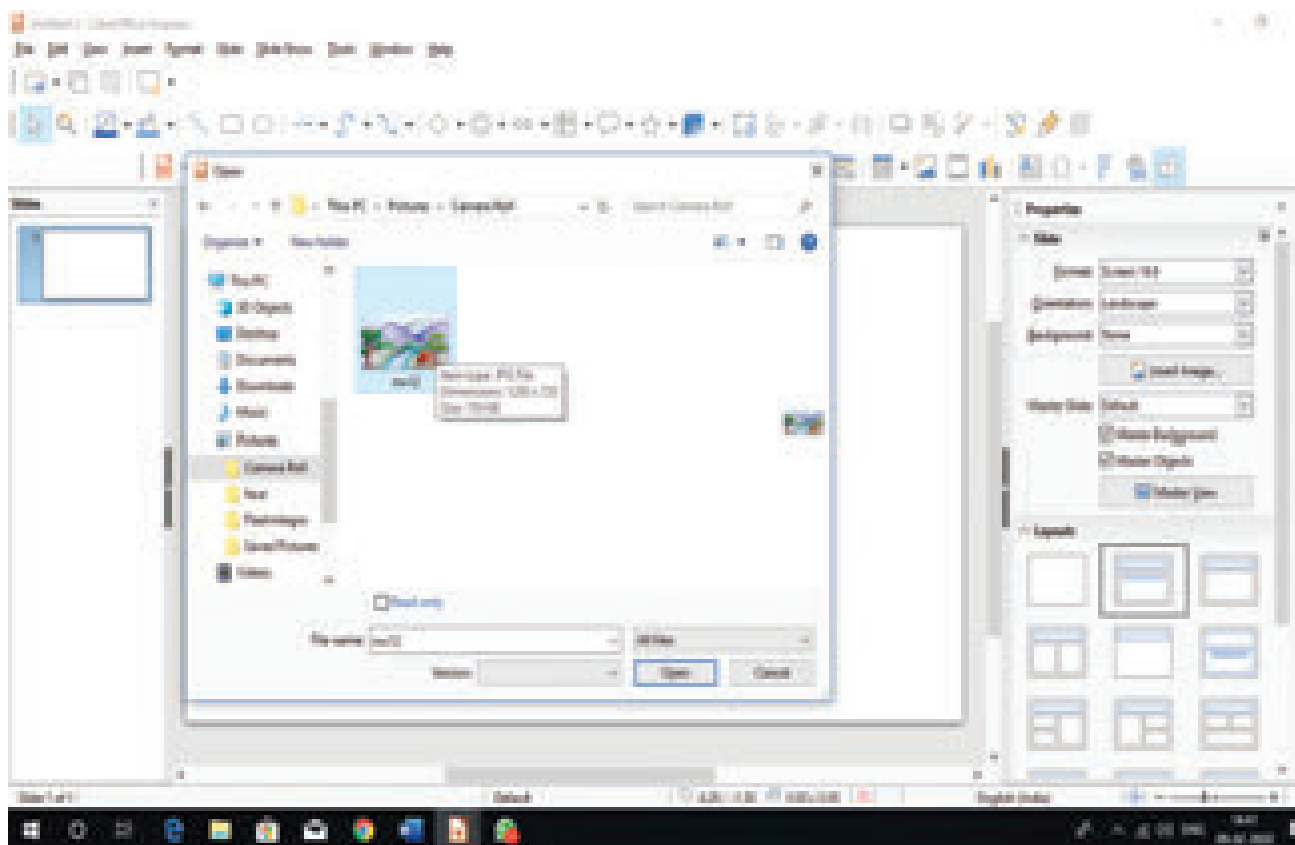
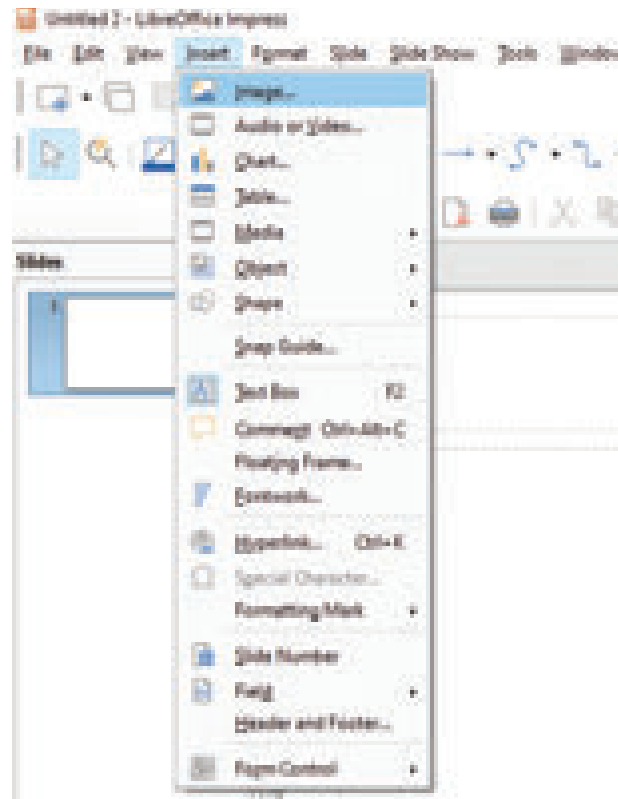

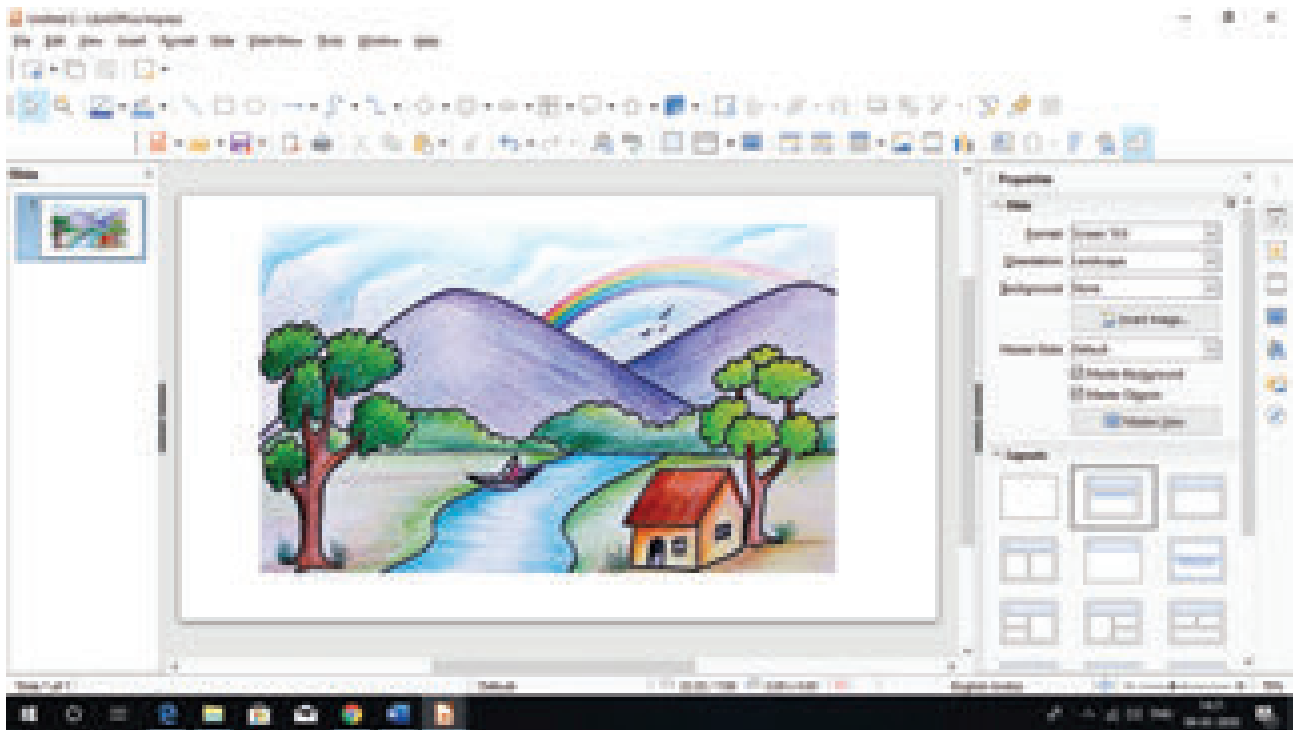

### 25.1.5 Inserting Text Box

Text box is used to add text anywhere on your slide.

To **add the text**, follow the given steps:

1. Select the slide where you want to add a Text Box.
2. Click the Insert Menu.
3. Click Text Box from the Text group.
4. Drag to draw a textbox where you want to add text.
5. Type whatever you want using the keyboard and click anywhere outside the text box.

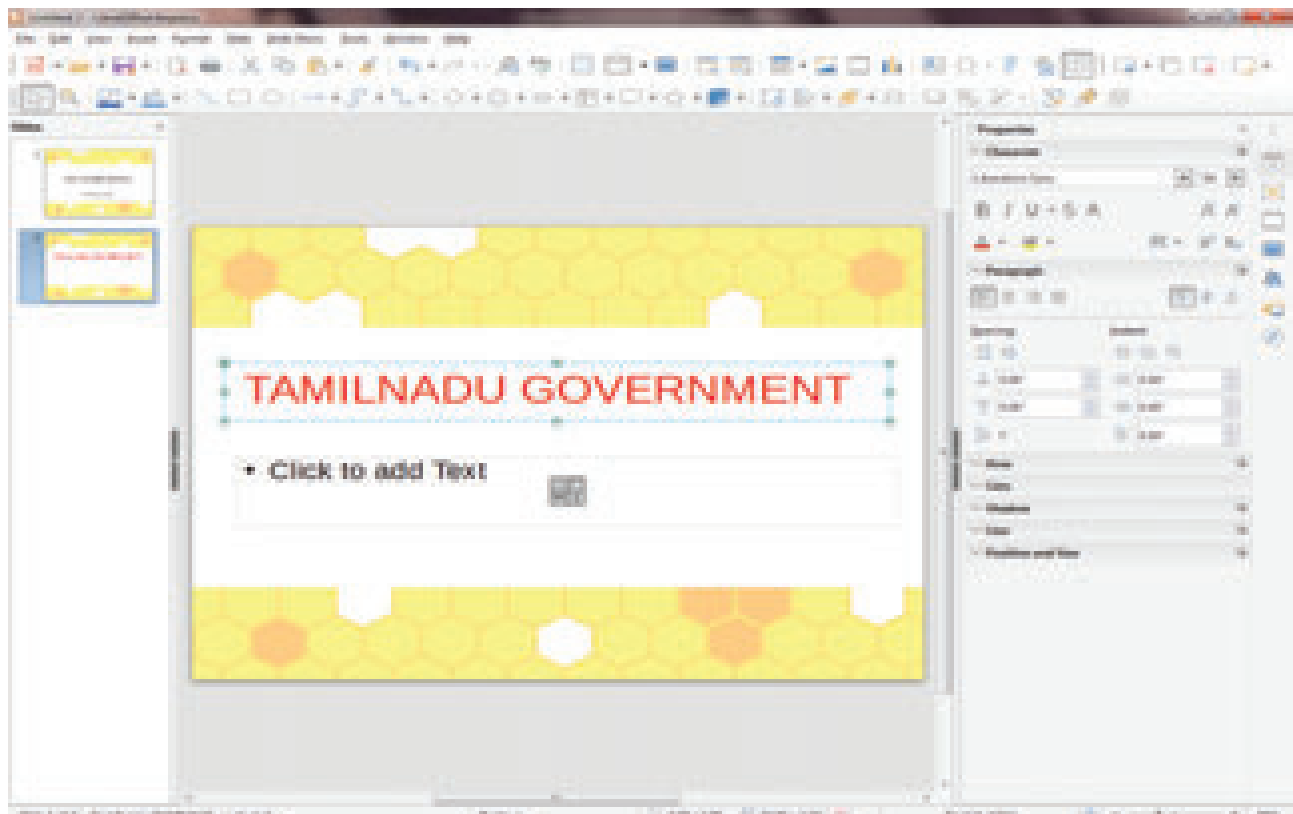

### 25.1.6 Insert audio and video files

You can insert audio video files to a slide to make your presentation more interesting. By default, LibreOffice provides audio and video clips that you can add to the presentation.

To insert an audio and video from the gallery, follow these steps.

1. Open the slide
2. Click insert menu then click audio/video option. Insert audio/video dialog box appears.
3. Locate and select the audio or video file to insert in the slide.

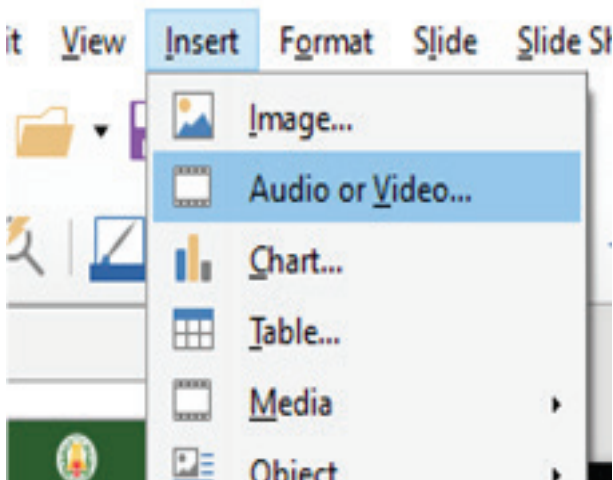

### 25.1.7 Slide Transition

Slide transitions are the effects that take place when one slide gives way to the next one in the presentation, like Roll down from top or Fly in from left. They add dynamic flair to a slideshow, smoothing the transition between slides.

- Click view menu and then press slide transition option.
- Now you can select any one of the transitions (or) you can choose Slide transition option from the Sidebar setting

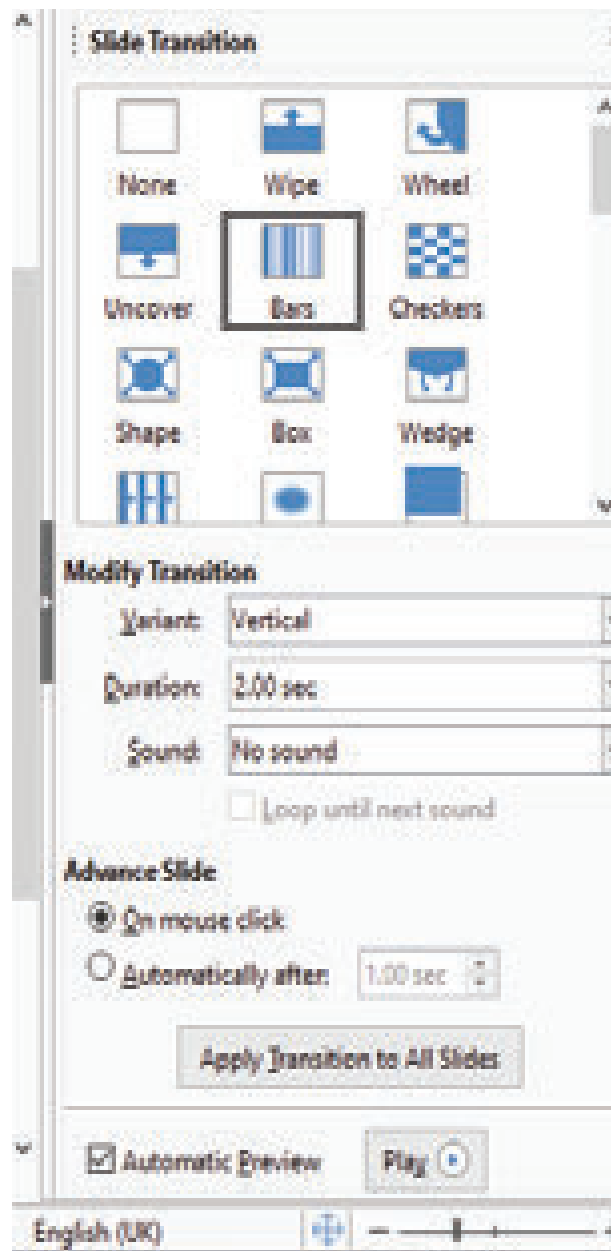

### 25.1.8 Animation

Slide animations are similar to transitions, but they are applied to individual elements in a single slide: title, chart, shape, or individual bullet point.

Select the slide and the object (text box, image) you want to apply the animation effect to. In the Sidebar, select Custom Animation icon to open the Custom Animation section. Select the animation effect types from one of the tabbed pages on the Custom Animation dialog.

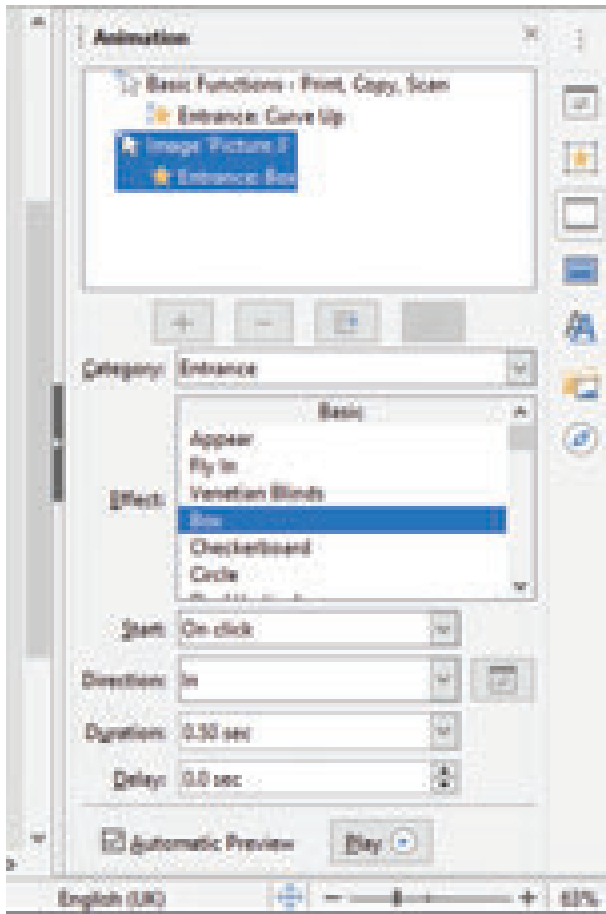

3. Type the file name.
4. Click the Save button.

### 25.1.11 Viewing a Slide Show

To have a look at how the actual presentation looks is called viewing a slide show.

To view a slide show, follow the given steps:

1. Click the Slide Show tab on the Ribbon.
2. Click **From Beginning** from the Start Slide Show group.

You can also press F5 Key on the Keyboard to start the slide show from the first slide .

You see your slides on full screen. Click your mouse each time to see the next slide.

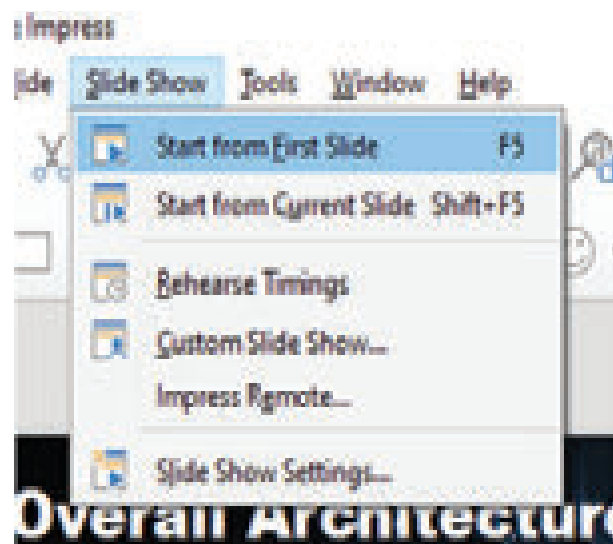

### 25.1.9 Deleting Slide

To delete a Slide, follow the given steps:

1. Select the slide you want to delete.
2. Click the Slide Menu.
3. Click Delete from the Slides menu. The slide gets deleted.

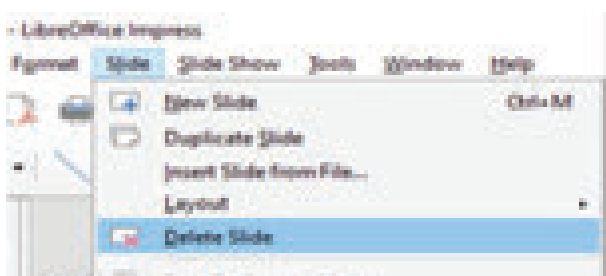

### 25.1.10 Saving a Presentation

To save a presentation, follow the given steps:

1. Click the File Menu.
2. Click the Save option. The Save As dialog box appears.

### 25.1.12 Closing a presentation

To close a presentation, follow the given steps:

1. Click File Menu.
2. Click Close option from the list.

If the current file is unsaved, LibreOffice Impress displays a dialog box asking you to choose whether or not to save your file.

Select Yes, if you wish to save the file or No, if you do not wish to save the file. You can choose Cancel, to return to your presentation without saving it.

### 25.1.13 Opening an Existing Presentation

To open an existing presentation, follow the given steps:

1. Click the File Menu.
2. Click the Open option. The open dialog box appears.
3. Select the file to be opened.
4. Click the Open button.

You can also open your file directly by clicking its name from the Recent Documents list.

### 25.1.14 Exit LibreOffice Impress

To Close LibreOffice Impress, follow the given steps:

1. Click the File Menu.
2. Click Exit LibreOffice Impress.



## TEXTBOOK EXERCISES



#### I. Choose the correct answer.

1. \_\_\_\_\_ is a structured delivery of information.  
a. Slide Show      b. Page  
c. WordArt          d. Presentation
2. The slides are grouped together in a sequence to form \_\_\_\_\_.  
a. slide show      b. sharts  
c. page              d. messages
3. A presentation consists of many \_\_\_\_\_.  
a. pages              b. slides  
c. placeholders      d. messages
4. which key should be pressed to run a slide show ?  
a. F1      b. Tab      c. F5      d. F2

5. \_\_\_\_\_ is used to insert attractive text in the slide.  
a. Slide Show      b. Word Art  
c. Text              d. Header and Footer

#### II. Answer briefly.

1. What is LibreOffice Impress?
2. What is a Presentation?
3. What is a Slide?
4. Write the steps to view a Slide Show.

#### III. Lab Work

1. Create a presentation on Festivals of Tamil Nadu. Save it with suitable name.





# PRACTICALS



## PRACTICAL - TABLE OF CONTENTS

Sl. No.	Name of the Experiment	Time	Month
1.	To find the diameter of a spherical body	40 minutes	June
2.	To find the thickness of given iron nail	40 minutes	October
3.	Melting point of wax	40 minutes	January
4.	Measurement of volume of liquids	40 minutes	July
5.	Identification of adaptations in animals	40 minutes	August
6.	Identification of plant and animal tissues	40 minutes	August
7.	To detect the adulterants in food samples	40 minutes	November
8.	Identification of microbes	40 minutes	November
9.	Economic biology	40 minutes	February
10.	Identification of adaptations in plants	40 minutes	February

## 1. TO FIND THE DIAMETER OF A SPHERICAL BODY

### Aim:

To determine the diameter of a spherical body using Vernier Caliper.

### Apparatus required:

Vernier Caliper, given spherical body ( cricket ball).



### Formula:

(i) Least count (LC) = 1 Main scale division - 1 Vernier scale division

$$LC = 1\text{mm} - 0.9\text{ mm}$$

$$LC = 0.1\text{ mm (or) } 0.01\text{ cm}$$

(ii) Diameter of the spherical object (d) = M.S.R. + (VC × LC) ± ZC cm

where, MSR - Main Scale Reading

VC - Vernier Coincide

LC - Least Count. (0.01 cm)

ZC - Zero Correction.

### Procedure:

- Find the least count of the Vernier caliper.
- Find the zero correction of the Vernier caliper.
- Fix the object firmly in between the two lower jaws of the Vernier.
- Measure the main scale reading and the Vernier scale coincidence.
- Repeat the experiment by placing the jaws of the Vernier at different position of the object.
- Using the formula find the diameter of the object.

Least Count (LC): 0.01cm

Zero Correction (ZC): \_\_\_\_\_

Sl. No.	Main Scale Reading (MSR) cm	Vernier coincidence (VC)	Diameter of object $d = \text{MSR} + (\text{VC} \times \text{LC}) \pm \text{ZC}$ (cm)
1			
2			
3			

Average \_\_\_\_\_ cm

**Result:** The diameter of the given spherical object (Cricket ball) is \_\_\_\_\_ cm

## 2. TO FIND THE THICKNESS OF GIVEN IRON NAIL

**Aim:**

To find the thickness of the given iron nail.

**Apparatus required:**

Screw gauge and iron nail



**Formula:**

$$(i) \text{ Least Count (LC)} = \frac{\text{Pitch scale Reading}}{\text{No of divisions in the Head scale}}$$

$$(ii) \text{ Thickness } (t) = \text{Pitch scale Reading (PSR)} + \text{Head scale coincidence (HSC)} \times \text{Least Count (LC)} \pm \text{zero correction}$$

$$t = \text{PSR} + (\text{HSC} \times \text{LC}) \pm \text{ZC}$$

**Error:**

(i) If positive error is 5 points, for zero correction, subtract 5 points.

$$t = \text{PSR} + (\text{HSC} \times \text{LC}) - \text{ZC}$$

$$t = \text{PSR} + (\text{HSC} \times \text{LC}) - 5$$

(ii) If negative error is 95 points, for zero correction add 5 points (100 - 95 = 5).

$$t = \text{PSR} + (\text{HSC} \times \text{LC}) + \text{ZC}$$

$$t = \text{PSR} + (\text{HSC} \times \text{LC}) + 5$$

(iii) If no correction is needed,  $t = \text{PSR} + (\text{HSC} \times 0.01) \pm 0$

**Procedure:**

- The Least count of screw gauge is 0.01 mm.
- The zero error is to be found when the two faces of the screw gauge touch each other.
- Then place the iron nail between the two faces of the screw gauge. The pitch scale reading (PSR) and head scale coincidence (HSC) are to be noted.
- Repeat the process by placing other parts of the iron nail in the screw gauge.
- Tabulate the readings.

	Zero correction:	Least count:	0.01 mm
Sl. No.	Pitch Scale Reading PSR (mm)	Head Scale Coincidence (HSC)	Thickness of the iron nail $t = \text{PSR} + (\text{HSC} \times \text{LC}) \pm \text{ZC}$ (mm)
1			
2			
3			

Average: \_\_\_\_\_ cm

**Result:** The diameter (Thickness) of the iron nail is \_\_\_\_\_ mm.



### 3. MELTING POINT OF WAX

#### Aim:

To determine the melting point of wax using cooling curve.

#### Principle:

The determination of melting point is based on latent heat which is the amount of heat required to change a unit mass (1gm) of a substance from one state to another state without changing its temperature.



#### Materials Required:

Beaker, burner, thermometer, boiling tube, retort stand and clamp, wire gauze, tripod stand, candle wax, stop watch, bowl of sand.

#### Procedure:

- Melt the wax in a warm water bath.
- When the wax is melted entirely, remove it from the bath, dry it and then bury it in sand.
- Record the temperature each 30 seconds while the liquid is being converted to solid.
- At the same time watch for constant temperature at which liquid and solid are present.

Melting point of wax = Constant Temperature over a period of time

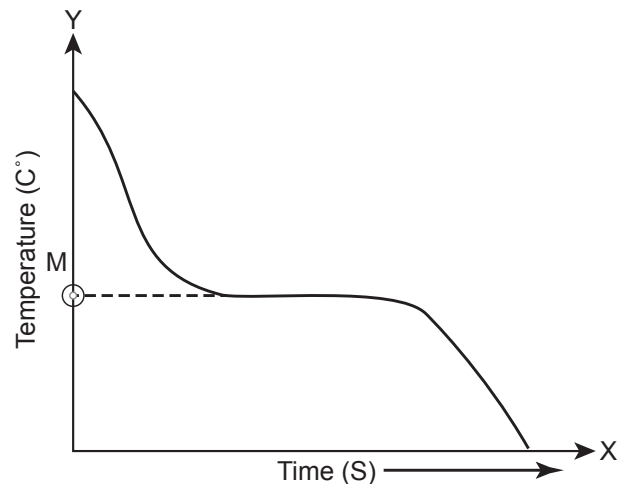
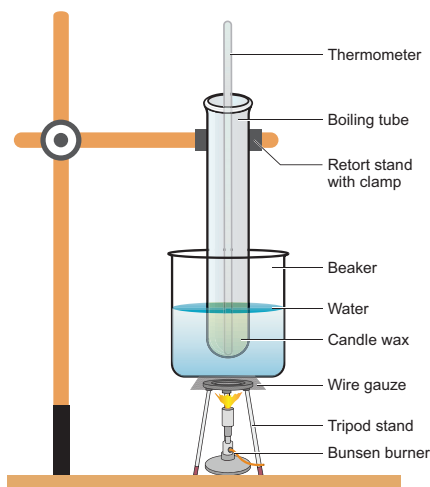

#### Observation and Tabulation:

S.No	Time (Second)	Temperature

The temperature at the point M denotes the melting point of wax

**Suggestion:** With the help of ICT corner, the teacher can show the live video of the experiment of melting point of wax using the link [www.kau.edu.sa](http://www.kau.edu.sa)



## 4. MEASUREMENT OF VOLUME OF LIQUIDS

### Aim:

To measure the volume of given colourless and coloured liquids.

### Materials required:

Pipette (20ml), sample liquids and beakers



### Procedure:

Take a 20 ml pipette. Wash it thoroughly with water and then rinse it with the given liquid. Insert the lower end of the pipette into the given liquid and suck the solution slowly till the solution rises well above the circular mark on the stem. Take the pipette out of the mouth and quickly close it with the fore finger. Take the pipette out the liquid and keep it such a way that the circular mark on the stem is at the level of the eyes. Now slowly release the fore finger to let the liquid drop out until the lower meniscus touches the circular mark on the stem. Now the liquid in the pipette is exactly 20 ml. This can be transferred to an empty beaker by removing the fore finger.

### Tabulation

Sl. No.	Name of the liquid	Colour of the liquid	Nature of the meniscus	Volume of the liquid
1				
2				
3				

**Report:** Exactly 20 ml of various liquids are measured using a standard 20 ml pipette.

### Note:

1. Keeping the circular mark on the stem of the pipette above or below the level of the eyes will lead to error.
2. When colored liquids are measured, the upper meniscus should be taken into account.
3. Never suck strong acids or strong alkalis using a pipette.

## 5. IDENTIFICATION OF ADAPTATIONS IN ANIMALS

### Aim:

To identify the given vertebrate animals and list out the adaptations seen in them.

### Required specimens:

1. Pisces (Fish), 2. Amphibian (Frog), 3. Reptile (Calotes), 4. Aves (Dove), 5. Mammal (Rat)



The following adaptations are noted.

Sl. No.	Name of the animal	Habitat	Body structure	Body covering	Locomotory organs
1	Fish				
2	Frog				
3	Calotes				
4.	Dove				
5.	Rat				

## 6. IDENTIFICATION OF PLANT AND ANIMAL TISSUES

### Aim:

To identify the structural features of plant and animal tissues from permanent prepared slides.



### Observation:

Identify the given plant and animal tissues.

- Simple tissues- parenchyma, collenchyma, sclerenchyma
- Complex tissues-xylem and phloem
- Epithelial tissue- columnar epithelium, ciliated epithelium
- Connective tissue- section of bone
- Muscle tissue- skeletal muscle, smooth and cardiac muscle
- Nerve tissue

Draw a labelled sketch and write the location and function of the tissues observed.

## 7. TO DETECT THE ADULTERANTS IN FOOD SAMPLES

### Aim:

To detect the adulterants in the given samples.

### Materials required

Beakers, glass bowl, spoon and match box.



### Food samples required:

Given samples: pepper (A), honey (B), sugar (C), chilli powder (D), green peas (E) and tea powder (F).

## Procedure:

- Take 5 beakers with water and label it as A, B, C, D, E.
- Take samples A, B, C, D, E and add water to the respective beaker.
- Observe the changes in each beaker.
- Record your observations.

## Observation:

Sl. No.	Sample	Observation	Indication
1.	A		
2.	B		
3.	C		
4.	D		
5.	E		
6	F		

## 8. IDENTIFICATION OF MICROBES

### Aim:

To identify the different types of microbes (Bacteria and Virus).



### Observation:

To observe and identify the following microbes with the help of photograph/picture/permanent slide using a compound microscope/model/biovisual chart.

- Escherichia coli*
- Vibrio cholerae*
- Lactobacillus*
- Retrovirus (HIV)*

### Answer the following:

- Draw a neat labelled diagram.
- Write the shape of the bacteria and virus observed.
- Mention the structural details of the bacteria and virus.
- Indicate its microbial importance/disease caused.



## 9. ECONOMIC BIOLOGY

### Aim:

To identify the plants and animals of economic importance.

### Observation:

To observe the following using specimen/photograph/picture/model.

- a. **Biofertilizer** – *Rhizobium*
- b. **Medicinal plants** – Nilavembu, *Aloe vera*
- c. **Mushroom** - *Agaricus bisporus*
- d. **Indigenous cattle breed** - Umblachery
- e. **Indian major carp** - *Catla catla*
- f. **Type of Honey bees** - Queen bee, Worker bee



### Answer the following:

- a. Draw a neat labelled sketch
- b. Write its economic importance

## 10. IDENTIFICATION OF ADAPTATIONS IN PLANTS

### Aim:

To identify the given plant specimen and list out its adaptations

1. Mesophytic plant – Tomato or Brinjal plant
2. Xerophytic plant – *Opuntia*
3. Aquatic plant – *Eichhornia sp*
4. Insectivorous plant – *Nepenthes*



### Observation:

The given plants are identified and the following adaptations are noted.

- 1.
- 2.
- 3.
- 4.
- 5.

## GLOSSARY

Absorption	- உட்கவர்தல், உறிஞ்சுதல்
Abundant Elements	- அதிக அளவு காணப்படும் தனிமம்
Acceleration	- முடுக்கம்
Adipose tissue	- நிணத்திசு. இரத்தச்சவ்வு, கொழுப்பிழையம்
Adulteration	- கலப்படம்
Aestivation	- கோடைகால உறக்கம்
Alkalis	- எரிகாரங்கள்
Allotropes	- புறவேற்றுமை வடிவம்
Alloys	- உலோகக் கலவைகள்
Alternating current	- மாறு மின்னோட்டம்
Amorphous	- படிக வடிவமற்ற
Animals	- விலங்குகள்
Anion	- எதிர்மின் அயனி
Aquaria	- இராஜதிராவகம்
Asteroid	- சிறுகோள்கள்
Atomic number	- அணு எண்
Atomic Structure	- அணு அமைப்பு
Autotrophic	- தற்சார்பு
Bell jar	- மணி ஜாடி
Bilateral Symmetry	- இரு பக்கச் சமச்சீர்
Biogeochemical Cycle	- உயிர் புவி வேதியியல் சுழற்சி
Biological Oxidation	- உயிரியியல் ஆக்ஸிசனேற்றம்
Buccal cavity	- வாய்க்குழி
Canning	- கலனடைத்தல்
Cardiac muscle	- இதயத்தசை
Cartilage	- குருத்தெலும்பு
Catalyst	- கிரியா ஊக்கி (வினையை வேகப் படுத்தும் தனிமம்)
Catenation	- சுய சகப்பிணைப்பு
Cation	- நேர்மின் அயனி
Centrifugal force	- மைய விலக்கு விசை
Centripetal force	- மையநோக்கு விசை
Chemical bond	- வேதிப்பிணைப்பு
chemotherapy	- வேதிய சிகிச்சை முறை
Coelom	- உடற்குழி
Colloidal solution	- கூழ்ம கரைசல்
Complex tissue	- கூட்டுத்திசு
Compound epithelium	- கூட்டு புறப்படலம்
Compounds	- சேர்மம்
Computer	- கணினி



Connective Tissue	- இணைப்புத்திசு, இணைப்பிழையம்
Coordinate covalent bond	- ஈதல் சகபிணைப்பு
Covalent bond	- சக பிணைப்பு
Crystallization	- படிகமாதல்
Deformation	- உருக்குலைவு
Dental Formula	- பற்குத்திரம்
Dialysis	- கூழ்மப்பிரிப்பு
Diploblastic	- ஈரடுக்கு
Direct current	- நேர் மின்னோட்டம்
Displacement	- இடப்பெயர்ச்சி
Distillation	- வடிகட்டுதல்
Ductile	- கம்பியாக நீட்டக் கூடிய
Echolocation	- எதிரொளியிடம்
Ectoderm	- புறஅடுக்கு
Electric cell	- மின்கலம்
Electric circuit	- மின்சுற்று
Electric energy	- மின்னாற்றல்
Electrical resistance	- மின்தடை
Electrochemical Cell	- மின்வேதிக்கலம்
Electrode	- மின்வாய்
Electrolyte	- மின்பகு திரவம்
Electromagnet	- மின்காந்தம்
Electrostatic	- நிலைமின்னியல்
Elements	- தனிமம்
Endangered species	- அழிவின் விளிம்பில் உள்ள சிற்றினங்கள்
Endoderm	- அகஅடுக்கு
Equator	- பூமத்திய ரேகை
Excretion	- கழிவு நீக்கம்
Fixed resistor	- நிலையான மின்தடை
Flame cell	- சுடர் செல்
Force	- விசை
Forensic Chemistry	- தடய வேதியியல்
Fossil water	- புதைபடிவ நீர்
Frequency	- அதிர்வெண்
Fuse	- மின்னூருகு இழை
Generator	- மின்னியற்றி
Genus	- பேரினம்
Geotropism	- புவிநாட்டம்
Glomerular filtration	- குளாமருலர் வடிகட்டுதல்
Heterogeneous	- பல படிக்தான தன்மை





Heterotrophic	- பிறசார்பு
Hibernation	- குளிர்கால உறக்கம்
Homoeothermic Animal	- வெப்ப இரத்த விலங்கு
Homogenous	- ஒரு படித்தான தன்மை
Hydrophytes	- நீர்வாழ்த் தாவரங்கள்
Hydrotropism	- நீர் நாட்டம்
Immunization	- நோய்த்தடுப்பு
Inert gases / Noble gases	- அரிய வாயு / மந்த வாயு
Inner Transition Elements	- உள் இடை நிலைத் தனிமம்
Input	- உள்ளீட்டகம்
Internal energy	- அகஆற்றல
Iron filings	- இரும்புத் துகள்கள்
IUPAC	- தூய மற்றும் பயன்பாட்டு வேதியலுக்கான சர்வதேசக் கழகம்
Kingdom	- உலகம்
Lamp Black	- விளக்கு கரி
Latent heat	- உள்ளுறை வெப்பம்
Least count	- மீச்சிற்றளவு
Levitate	- மிதத்தல்
Ligament	- தசை நாண், தசை நார்
Longitudinal waves	- நெட்டலைகள்
Malleable	- தகடாகும் தன்மையுடைய
Mantle	- மேன்டல் உறை
Mass number	- நிறை எண்
Meiosis	- குன்றல் பிரிவு, ஒடுக்கற் பிரிவு
Melting	- உருகுதல்
Mesoglea	- நடு அடுக்கு
Metalloids	- உலோகப் போலிகள்
Meteorological	- வானிலை ஆய்வு
Mixture	- கலவை
Momentum	- உந்தம்
Motion	- இயக்கம்
nano	- நூறு கோடியில் ஒன்று என்பதன் முன்னொட்டு (10 <sup>-9</sup> )
Nocturnal	- இரவில் இயங்கும்
Non polar solvent	- முனைவற்ற கரைப்பான்
Notochord	- முதுகு நாண்
Nucleus	- அணு உட்கரு
Octaves	- எண்மம்
Octet rule	- எண்ம விதி
Olericulture	- காய் கறி மற்றும் உணவுத்தாவரங்களை வளர்த்தல்
Operculum	- செவுள் மூடி





Optical fibers	- ஒளி இழை
Orbital Velocity	- சுற்றியக்கத் திசைவேகம்
Order	- வரிசை
Output	- வெளியீட்டகம்
Oxidation	- ஆக்ஸிஜனேற்றம்
Oxidation number	- ஆக்ஸிஜனேற்ற எண்
Pasteurization	- பாஸ்டர் பதனம் / பாஸ்டிரை சேஷன்
Penetrate	- ஊடுருவுதல்
Permanent Tissues	- நிலைத்த திசுக்கள்
Pharmacology	- மருந்தியல்
Phloem	- புளுயம் (பட்டையம்)
Photosynthesis	- ஒளிச்சேர்க்கை
Phototropism	- ஒளிநாட்டம்
Phylum	- தொகுதி
Piston	- உந்து தண்டு
Plane mirror	- சமதள ஆடி
Planet	- கோள்
Plants	- தாவரங்கள்
Poikilothermic Animal	- குளிர் இரத்த விலங்கு
Polymorphism	- பல்லுருவமைப்பு
Potential difference (Voltage)	- மின்னழுத்த வேறுபாடு
Potential difference (Voltage)	- மின்னழுத்த வேறுபாடு
Preservatives	- பதப்படுத்திகள்
Pressure	- அழுத்தம்
Propagation	- பரவுதல்
Pump	- இறைப்பான்
Radial Symmetry	- ஆர சமச்சீர்
Radiation	- கதிரியக்கம்
Radioactive decay	- கதிரியக்க சிதைவு
Radiocarbon dating	- கதிரியக்க கார்பன் வயதுக்கணிப்பு
Radiochemistry	- கதிரியக்க வேதியியல்
Range of hearing	- செவியுணர் நெடுக்கம்
Rarefactions	- தளர்ச்சிகள்
Real and virtual image	- மெய் மற்றும் மாயபிம்பம்
Reflection of sound	- ஒலி எதிரொளித்தல்
Refraction	- ஒளி விலகல்
Remote control	- தொலையுணர்வி
Resin code	- ரெசின் (பிசின்) கோடு
Resistor	- மின்தடையம்
Reverberation	- எதிர்முழக்கம்





Rheostat	- மின்தடை மாற்றி
Space Station	- விண்வெளி நிலையம்
Species	- சிற்றினம்
Specific latent heat	- தன் உள்ளுறை வெப்பம்
Spherical mirrors	- கோளக ஆடிகள்
Stomata	- இலைத்துளை
Sub phylum	- துணைத் தொகுதி
surface	- மேற்பரப்பு
Symbiotic Microbes	- கூட்டுயிர் நுண்ணுயிர்கள்
Taxonomy	- வகைப்பாடு
Tendons	- தசை நாண் (நாண்)
Tetavalency	- நான்கு இணைதிறன்
Therapy	- சிகிச்சை
Time period	- அலைவுக் காலம்
Total internal reflection	- முழு அக எதிரொளிப்பு
Toxic	- நஞ்சு
Transmitting	- கடத்தி
Transpiration	- நீராவிப்போக்கு
Transverse waves	- குறுக்கலைகள்
Triads	- மும்மை
Trough	- அகடு
Tubular reabsorption	- குழாய்வழித்திரும்ப உறிஞ்சுதல்
Ultrasonics	- மீயொலி
Underactive	- குறைந்த அளவு வினை புரியும் தன்மை கொண்ட
Uniform motion	- சீரான இயக்கம்
Universe	- பிரபஞ்சம் / அண்டம்
Vaccination	- தடுப்பான்கள் / அம்மை குத்துதல்
Valance Electrons	- இணை திறன் கொண்ட எலக்ட்ரான்கள்
Valence	- இணைதிறன்
Variable resistor	- மாறு மின்தடை
vase	- குவளை, திறந்த கொள்கலன்
Velocity	- திசைவேகம்
Vermiculture	- மண்புழு வளர்ப்பியல்
Vulnerable species	- பாதிப்புக்குள்ளான சிற்றினங்கள்
Xerophytes	- வறண்ட நிலத்தாவரங்கள்
Xylem	- சைலம் (மரவியம்)
Zero error	- சுழிப்பிழை
Zero Valence	- சுழி இணைதிறன்



## Science – Class IX

### List of Authors and Reviewers

#### Advisory Committee

- Dr. T.V. Venkateswaran**, Scientist,  
Department of Science and Technology,  
Vigyanaprasar, Delhi.
- Dr. Dinakar**, Associate Professor,  
Madura College of Arts and Science, Madurai.
- Dr. Udhra D**, Asst. Professor,  
Dept. of physics, D.G.Vyshnava College, Chennai.
- Margarette David Raj**, Principal,  
Bakthavatchalam Vidyasharam, Chennai
- Tmt. Vijayalakshmi Srivatsan**,  
Principal (Retd), Ps. Senior Sec.School, Chennai-4

#### Domain Experts

- Dr. Sultan Ahmed Ismail**, Scientist,  
Eco Science Research Foundation, Chennai.
- Dr. Rita John**, Professor and Head,  
Department of Theoretical Physics,  
University of Madras, Chennai.
- Dr. C.V Chitti Babu**, Associate Professor,  
Dept. of Botany, Presidency College, Chennai.
- Dr. T.S. Subha**, Associate Professor and Head,  
Dept. of Botany, Bharathi Women's College, Chennai.
- Dr. N. Sarojini**, Assistant Professor,  
Dept. of Zoology, Bharathi Women's College, Chennai.
- Dr. R. Sugaraj Samuel**, Asst. Professor,  
Dept. of Physics, The New College, Chennai.
- Dr. G. Ramesh**, Asst. Professor,  
PG & Research Department of Chemistry,  
Dr. Ambedkar Govt Arts College, Chennai.
- Boopathi Rajendran**, Deputy Director,  
Directorate of Elementary Education, Chennai.
- Dr. N. Radha Krishnan**, Associate Professor,  
Dept. of Botany, University of Madras, Chennai.
- Dr. K. Chinthanaiyalan**, B.T. Asst.,  
GHS, Periyar Nagar Nandambakkam, Kancheepuram.

#### Content Writers

- Dr. R. Saravanan**, Asst. Professor,  
PG & Research Department of Zoology,  
Dr. Ambedkar Govt Arts College, Chennai.
- Dr. S.K. Geetha**, Asst. Professor,  
PG & Research Department of Physics,  
Govt. Arts College for Men, Chennai.
- Dr. P. Priya**, Asst. Professor,  
PG & Research Department of Zoology,  
Pachaiyappa's College, Chennai.
- Dr. Kanakachalam**, Asst.Prof.,  
Govt. Arts College, Erode.
- Dr. R. Asir Julius**, Asst. Professor,  
SCERT, Chennai.
- G. Dhavamani Maheswari**, Senior Lecturer  
DIET, Tirur, Tiruvallur District.
- N. Rajendran**, Lecturer,  
DIET, Kizhapazhuvur, Ariyalur.

- V. Jagathratchagan**, Headmaster,  
GHSS, Naduveerapattu, Cuddalore.
- Snehalatha Dawson**, HM (Retd),  
Dovetton Corrie (G) HSS, Chennai.
- R. Vendhan**, P.G.T., GBHSS, Krishnagiri.
- S. Ravisankar**, PGT., SRM HSS, Ambattur, Chennai.
- T. John Prince**, P.G.T.,  
NLC GHSS, Block-2, Neyveli, Cuddalore.
- S. Geetha**, P.G.T., Jawahar HSS, Ashok Nagar, Chennai.
- J. Nagarajan**, P.G.T., GHSS, Kadampuliyur, Cuddalore.
- A. Sreekumari**, PGT, GK Shetty Hindu Vidhayalaya MHSS,  
Adhambakkam, Kanchipuram.
- S. Selvabharath**, PGT,  
Municipality GHSS, Mettupalayam.
- K. Mohana Chandran**, PGT, Ellen Sharma  
Memorial MHSS, Sozhinganallur, Kanchipuram.
- M. Sujatha**, PGT, MGHSS, Thiruvannamalai.
- R. Thilaikarasi**, PGT, GK Shetty Hindu Vidhayalaya MHSS,  
Adhambakkam, Kanchipuram.
- P. Jeyaraj**, PGT, GHSS, Munsirai, Kanyakumari.
- Dr. K. Chinthanaiyalan**, B.T. Asst.,  
GHS, Periyar Nagar Nandambakkam, Kancheepuram.
- T. Yuvaraj**, Lecturer, DIET Chennai.
- P. Nirmala Devi**, B.T. Asst.,  
GHS, Kalaiyur, Ramnad.
- A. Satheeshkumar**, B.T. Asst.,  
GHSS, Rajendranagar, Theni.
- C. Rajasekar**, B.T. Asst.,  
GGHSS, Kundrathur, Kancheepuram.
- P. Kalaiselvan**, B.T. Asst.,  
Thiruvalluvar HSS, Gudiyaththam, Vellore.
- M.S. Shanthi**, B.T. Asst., GGHSS, Ashok Nagar, Chennai.
- S. Sujatha**, Academic Coordinator,  
Alpha International School, Sembakkam, Chennai.
- K.A. Sharmila**, B.T. Asst,  
Lady Sivaswamy Ayyar GHSS, Mylapore, Chennai.
- R. Ramyadevi**, B.T. Asst.,  
GHSS, Medavakkam, Kancheepuram.
- B. Leo**, B.T., GHS, R.N. Pudur, Erode
- Santhosh J.C. Vinobah**, B.T.,GHS, Thachur,  
Kanniyakumari
- N. Caroline Joseph**, Dovetton Corrie (G) HSS, Chennai.
- S. Sujatha**, B.T. Asst., Miyasi MHSS, Chennai.
- S.C. Selvathangam**, B.T. Asst.,  
GHS, Mannivakkam, Kanchipuram
- F. Davin Lalitha Mary**,  
Christ the King MHSS, East Tambaram, Chennai.
- M.G. Elango**, GHSS, Pandhalkudi, Virudunagar.
- K.V. Durga**, GHSS, Ayyankarkulam.
- Ribhu Vohra**,  
WasteLess, Auroville, Puducherry.

## Content Readers

**Dr. Mazher Sulthana**, Professor, (Retd.)  
Dept. of Zoology, Presidency College, Chennai.

**C. Joseph Prabagar**, Asst. Professor,  
Department of Physics, Loyola College, Chennai.

**Dr. P. Arulmozhichelvan**, Associate Prof & Head,  
Pachayappa's College, Chennai.

**Dr. S. N. Balasubramanian**, Associate Prof.,  
Presidency College, Chennai.

**Dr. V. Sivamadhavi**, Associate Prof.,  
Bharathi women's College, Chennai.

**Dr. M. Pazhanisamy**, Associate Prof.,  
Govt. Arts College, Nandanam, Chennai.

**Dr. G. Diraviam**, Associate Prof.,  
Govt. Arts College, Nandanam, Chennai.

**Dr. S. Seshadri**, Asst. Prof.,  
Dr. Ambedkar Govt Arts College, Chennai.

**Dr. S. Sreedevi**, Asst. Prof.,  
Bharathi Women's College, Chennai.

**Dr. Shameem**, Deputy Director, SCERT, Chennai.

**Dr. G. Muthuraman**, Asst. Prof.,  
Presidency College, Chennai.

**Dr. S. Abdul Khader**, Asst. Prof.,  
Presidency College, Chennai.

**Dr. R. Rajeswari**, Asst. Prof.,  
Quaid-E-Millath Govt. Arts College, Chennai.

**Dr. N. Afsar**, Asst. Prof., Govt. Arts College, Ponneri.

**Dr. G. Rajalakshmi**, Asst. Prof.,  
Bharathi Women's College, Chennai.

**Dr. S. George**, Asst. Prof., Govt. Arts College, Ponneri.

**D. Arnold Robinson**, Asst. Professor,  
Meston College of Education, Chennai.

**Dr. S. Devashankar**, Asst. Prof.,  
Govt. Arts College, Ponneri.

**Mrs. Malathi**, VP,  
CSI Bain MHSS, Kilpauk, Chennai.

**P. Kamalee**, Lecturer, DIET, Thiruvannamalai.

**C. Anbarasan**, Lecturer, DIET, Salem.

**B. Uthayakumar**, Lecturer, DIET, Salem.

**P. Maheshwari**, CEO, Kanchipuram.

**M. Palanichami**, HM,  
GHSS, Krishnarayapuram, Karur.

**Dr. S. Ravi Kasi Venkataraman**, PGT,  
GHSS, Semmancheri, Chennai.

**N. Mahesh Kumar**, PGT,  
Dist. Coordinator, CEO Office, Namakkal.

**S. Thiyagarajan**, PGT, GHSS, Thirumalpur, Vellore.

**Dr. S. Shankar**, PGT,  
GHSS, Thiruputkuzhi, Kanchipuram.

**Dr. N. V. S. Sarojini Krishna**, PGT,  
GHSS, Palur, Kanchipuram.

**G. Shanthi**, PGT,  
GHSS, Singadivakkam, Kanchipuram.

**A. Prabhakaran**, PGT,  
SRS MHSS, Ambature, Chennai.

**T. Subbiah**, PGT,  
GGHSS, Achirapakkam, Kanchipuram.

**N. Thamarai Kannan**, PGT,  
GHSS, GGNHSS, Tambaram. Chennai.

**A. Guru Prasad**, Lecturer,  
Kaliyanpoondi, Kanchipuram.

**K. Ramesh**, BT, GHS, Esur, Kanchipuram.  
**Ms. V. Prithimala**, CSI BAIN MHSS, Kilpauk, Chennai.  
**V. Jayalakshmi**, BT, GHSS, Arumbakkam, Chennai.

## Subject Expert & Coordinator

**Dr. K. Chinthanaiyalan**, B.T. Asst.,  
GHS, Periyar Nagar, Nandambakkam, Kancheepuram.

## Subject In-Charge

**Dr. Vanitha Daniel**, Principal,  
DIET, Kurukathi, Nagapattinam.

## Coordinator

**S. Lakshmi**, B.T. Asst., GGHSS Manalurpet, Villupuram.

## Career Guidance

**Dr. T. Sankara Saravanan**, Deputy Director,  
Tamilnadu Textbook and Educational services Corporation,  
Chennai.

## ICT Coordinators

**R. Ravi kumar**, Lecturer, DIET, Chennai.  
**S. Shyamala**, B.T. Asst.,  
ADW High School, Puliyanthope, Chennai.  
**A. Ajay**, S.G.T., PUMS Nanthimangalam,  
Kumaratchi Block, Cuddalore.

## QR Code Management Team

**R. Jagannathan**, S.G. Asst., PUMS Ganesapuram Polur,  
Thiruvannamalai.  
**A. Devi Jesintha**, B.T. Asst.,  
GHS, N.M. Kovil, Vellore.  
**J.F. Paul Edwin Roy**, PUMS, Rakkipatti, Salem.  
**N. Jagan**, B.T. Asst.,  
GBHSS, Uthiramerur, Kanchipuram.  
**J.F. Paul Edwin Roy**, PUMS, Rakkipatti, Salem.  
**M. Janakiraman**, B.T. Asst.,  
PUMS, Mattayambatti, Salem.

## Art and Design Team

**Layout**  
Gopinath Ragupathi, Yogesh B,  
A. Adison Raj, Selvakumar Manickam

## Illustration

Gopu Rasuvel, Muthu Kumar R, Sasikumar K

## In-House

Rajesh Thangappan, Manohar Radhakrishnan  
Kamatchi Balan Arumugam

## Wrapper Design

Kathir Arumugam

## Co-ordination

Ramesh Munisamy

## Typist

A. Sabiah Banu, M. Sathya, A. Kavitha

This book has been printed on 80 G.S.M.  
Elegant Maplitho paper.

Printed by offset at: